



VSD

Operations Committee Meeting
Tuesday, August 2, 2022 at 1:00 PM
Valley Sanitary District Board Room,
45-500 Van Buren Street, Indio, CA 92201

Valley Sanitary District is open to the public and board meetings will be conducted in person. In addition to attending in person, members of the public may view and participate in meeting via the following

Zoom link:<https://us06web.zoom.us/j/89066375776>

Meeting ID:890 6637 5776

To address the Board of Directors during the virtual live session via zoom, please email the Clerk of the Board at hgould@valley-sanitary.org or, alternatively, during the specific agenda item or general comment period (i.e. non-agenda items), please use the "raise your hand" function in zoom in order to be recognized by the Clerk of the Board in order to provide comments in real time.

The Clerk of the Board will facilitate to the extent possible any email requests to provide oral testimony that are sent during the live meeting. Members of the public may provide Oral testimony in person or during the virtual live session and are limited to three minutes each. To address the Board in person please complete speaker request card located at in the Board Room and give it to the Clerk of the Board.

If you are unable to provide comments during the meeting, written public comments on agenda or non-agenda items may be submitted by email to the Clerk of the Board at hgould@valley-sanitary.org. Written comments must be received by the Clerk of the Board no later than 11:00 a.m. on the day of the meeting.

Page

1. CALL TO ORDER

1.1. Roll Call

1.2. Pledge of Allegiance

2. PUBLIC COMMENT

This is the time set aside for public comment on any item not appearing on the agenda. Please notify the Secretary in advance of the meeting if you wish to speak on a non-hearing item.

3. DISCUSSION / ACTION ITEMS

3.1. Approve Minutes for June 7, 2022, Regular Committee Meeting 4 - 5

[3.1 Operations Committee Minutes 7 Jun 2022.pdf](#) 

3.2. Discuss Public-Private Partnership (P3) Options for Biosolids Management and Provide Feedback 6 - 119

[3.2 Staff Report Biosolids P3 Options.pdf](#) 

[3.2 Attachment A Biosolids Project Flyer.pdf](#) 

[3.2 Attachment B Lystek Solution Final.pdf](#) 

[3.2 Attachment C Lystek Case Study FSSD Jan2021.pdf](#) 

[3.2 Attachment D Bioforcetech-Q-22-699.pdf](#) 

[3.2 Attachment E Biosolids to Bricks Research.pdf](#) 

3.3. Discuss the Updated Guidance Documents Sewer Use Ordinance (SUO), Enforcement Response Plan (ERP), and Local Limits and Provide Feedback 120 - 274

[3.3 Staff Report Updated Guidance Documents SUO ERP.pdf](#) 

[3.3 Attachment A SUO Update OPS Committee Presentation EOA \(003\).pdf](#) 

[3.3 Attachment B VSD Sewer Use Ordinance RLSO 20220607.pdf](#) 

[3.3 Attachment C VSD ERP Rev20220603.pdf](#) 

[3.3 Attachment D VSD Local Limits 2022 draft compiled.pdf](#)



- 3.4. Discuss the Purchase of a Combination Cleaning Truck for the District and Provide Feedback

275 - 305

[3.4 Staff Report Purchase of a Combination Cleaning Truck.pdf](#)

[3.4 Conference](#)

[Presentations_2018_Combo_SewerTruck_Recycler-Abramowski.pdf](#)

4. ADJOURNMENT

Pursuant to the Brown Act, items may not be added to this agenda unless the Secretary to the Board has at least 72 hours advance notice prior to the time and date posted on this notice.

**VALLEY SANITARY DISTRICT
OPERATIONS COMMITTEE MEETING MINUTES
June 7, 2022**

A regular meeting of the Valley Sanitary District (VSD) Operations Committee was held at Valley Sanitary District, 45-500 Van Buren St, Indio, CA, on Tuesday, June 7, 2022.

1. CALL TO ORDER

Ron Buchwald called the meeting to order at 1:03 p.m.

1.1 Roll Call

Committee Members Present:
Committee Member Mike Duran

Staff Present:
Beverli Marshall, General Manager; Ron Buchwald, Engineering Services Manager;
James Mills, Operations Supervisor; and Holly Gould, Clerk of the Board

1.2 Pledge of Allegiance

2. PUBLIC COMMENT

This is the time set aside for public comment on any item not appearing on the agenda. Please notify the Secretary in advance of the meeting if you wish to speak on a non-hearing item.

None.

3. DISCUSSION / ACTION ITEMS

3.1 Process Modification for Ammonia Removal Pilot Project Phase 2

James Mills, Operations Supervisor, stated that in 2020, the State of California Colorado River Basin Regional Water Quality Control Board required the District to complete within 18-months an Ammonia Technical Study. The study was to evaluate the ability of the treatment facility to reduce ammonia discharges into the Coachella Valley Whitewater Storm Water Channel. Phase 1 of the Ammonia Pilot Project demonstrated that the current plant could be modified to remove ammonia from the plant effluent. Staff was able to achieve plant effluent ammonia requirements frequently below 2.0 mg/L. Since the completion of Phase 1, the District wanted to evaluate additional process modifications that would provide consistent, reliable nitrification/denitrification with effluent ammonia levels below 2.0 mg/l or less. During this phase of the project, Aeration Basin No. 4 will be modified into a Single Sludge, Pre-Anoxic process configuration (Modified Ludzak-Ettinger configuration). This requires constructing a temporary internal nitrate recycle pipeline from the backend end of the aeration basin to the front of the anoxic selector in Basin No. 4. This is being done by repurposing facility equipment and using temporary plastic pipe. Phase 2 of the pilot study is committed to developing consistent, reliable nitrification/denitrification with effluent ammonia levels below 2.0 mg/L or less. Director Duran inquired what the future costs could be if this process proves successful. James stated that it would involve modifying each aeration basin with a pump and piping. He also noted that this has been a great team effort from everyone in the Operations Department.

3.2 Project Update: Influent Pump Station Rehabilitation Project

The District awarded the Design/Build project to Downing Construction and Dudek Engineering. The initial project consisted of installing a sewer main by-pass to thoroughly inspect the influent pump station to determine the necessary repairs. The design and construction estimate was completed with a Guaranteed Maximum Price set at \$2,921,971. The final award by the Board was approved on April 26, 2022. Downing / Dudek is in the process of acquiring the materials to install the sewer main by-pass around the pump station. Ron Buchwald, Engineering Services Manager, stated that the bonds and insurance had been submitted, and the shop drawings are under engineering review. The project is running about a month behind schedule. The sewer main by-pass is expected to be installed in June and continuously active for about six months. The project is estimated to be completed by the end of January 2023.

3.3 Lift Station Condition Assessment Report Review

In February 2022, Harris & Associates (Harris), along with two subconsultants, performed a full inspection of each of the District's four lift stations. Overall, the condition assessment did not find any issues that required immediate action to prevent imminent structural or critical equipment failure. The lift stations are generally in moderate to good working condition. The significant recommendations across the four lift stations involve new wet well linings, mechanical coatings, and upgrading outdated electrical equipment. The recommended improvements are based on deteriorating asset conditions, outdated equipment with increased failure and safety risk, and assets nearing their useful life. Even though the four lift stations are in moderate to good condition, there are several recommended repairs to be made to each lift station over the next 2 to 5 years. Calhoun lift station had the highest priority, followed by Carver and Barrymore lift stations in second place, and then Vandenburg lift station with the lowest priority. Harris is also looking at relocating the Carver lift station from the roadway to an adjacent parcel as part of a second report. A discussion took place on the relocation of the Carver lift station. Beverli Marshall, General Manager, stated that she would reach out to the Board of Supervisors to let them know that this is an area of interest and the benefit that the Carver lifter station would provide to the community. Staff will also reach out to a real estate professional to get more information on the parcels of interest.

4. **ADJOURNMENT**

There being no further business to discuss, the meeting adjourned at 2:10 p.m. The next regular committee meeting will be held on August 2, 2022.

Respectfully submitted,
Holly Gould, Clerk of the Board
Valley Sanitary District



**Valley Sanitary District
Operations Committee Meeting
August 2, 2022**

TO: Operations Committee

FROM: Beverli A. Marshall, General Manager
Dave Commons, Chief Operations Officer

SUBJECT: Discuss Public-Private Partnership (P3) Options for Biosolids Management and Provide Feedback

Executive Summary

The purpose of this report is for the Committee to meet discuss the District's processing and disposal of its biosolids and viable options for future reuse of this byproduct.

Strategic Plan Compliance

This item complies with VSD Strategic Plan Objective 2.1: Increase recycling and reuse of resources and byproducts.

Fiscal Impact

There is no cost from this discussion.

Background

Solids removed during the wastewater treatment process results in biosolids. There are generally four allowable methods for disposal of this byproduct.

1. Land application – (the District's current disposal method) biosolids are hauled to another site and prepared for use on allowable crops as soil conditioners.
2. Incineration – California no longer allows this except for a small number of agencies that have been grandfathered in for this method.
3. Landfilling – this method is going extinct in California due to zero waste goals.
4. Surface disposal – permanent stockpiling of biosolids if no identifiable use.

Historically, the most widely used means for disposal of this byproduct is land application as soil conditioners or fertilizer for crops.

Biosolids Use & Disposal from Biosolids Annual Program Reports in 2019

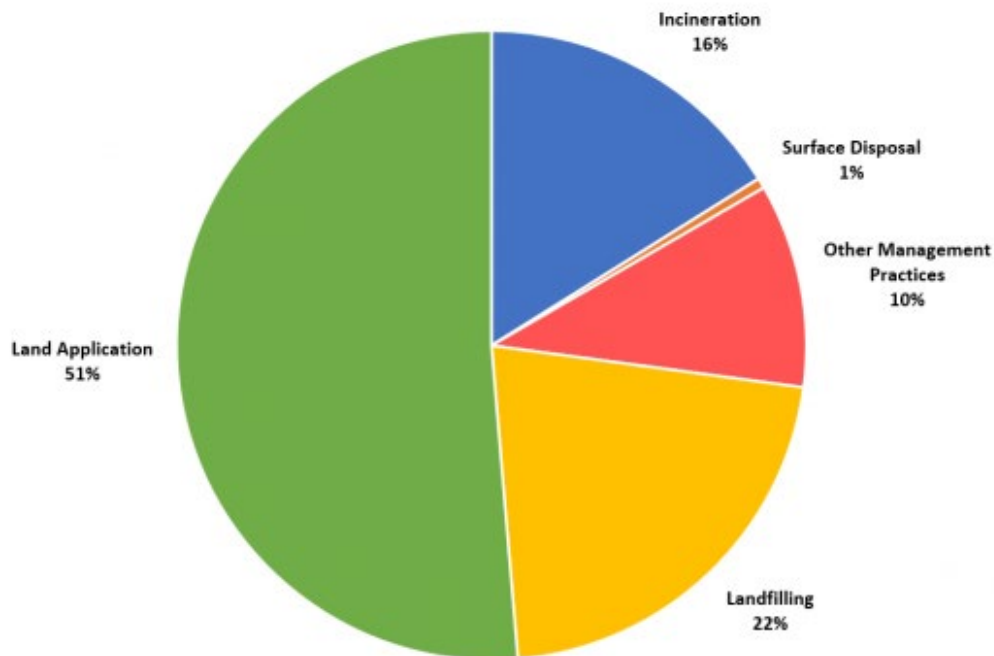

5. As a soil conditioner or fertilizer, biosolids are sought after because of its nutritional benefits. Currently, VSD hires a hauler to take the biosolids to Arizona where it is applied on crops identified as being able to accept it for this purpose. This option is becoming more difficult because of zero waste goals and more stringent regulatory issues in California and Arizona. For Budget year FY 2023, VSD budgeted \$200,000 for hauling dewatered biosolids to Arizona.

Recent technological advances have created other markets for this product.

- Biochar – a carbon-based product that can be used as an additive
- Liquid fertilizer – an easily applied, low-cost fertilizer
- Sustainable construction materials – sustainable bricks and concrete

The next step is to select the end product and technology, identify the private partnership, and find funding for the project.

More information about biosolids can be found on the EPA's website at:
<https://www.epa.org/biosolids/basic-information-about-biosolids>.

Recommendation

Staff recommends that the Committee discuss public-private partnership (P3) options for biosolids management and provide feedback.

Attachments

Attachment A: Sustainable Biosolids Management Project Flyer

Attachment B: Lystek Solution Final

Attachment C: Lystek Case Study FSSD Jan2021

Attachment D: Bioforcetech Q-22-699

Attachment E: Biosolids to Bricks Research

Valley Sanitary District Sustainable Biosolids Management Project



Challenges: Long-Term Solution

- Rising cost of hauling and permitting
- Diversion from landfill required
- Regulatory pressure to find beneficial uses
- Requires time and storage space
- No local or regional alternatives

Project: Organic Material Recovery

- High-quality crops and increased yields
- Enrich and condition soil
- Carbon reduces need for irrigation water
- Lower carbon footprint with local uses
- Low-cost compared to synthetic solutions

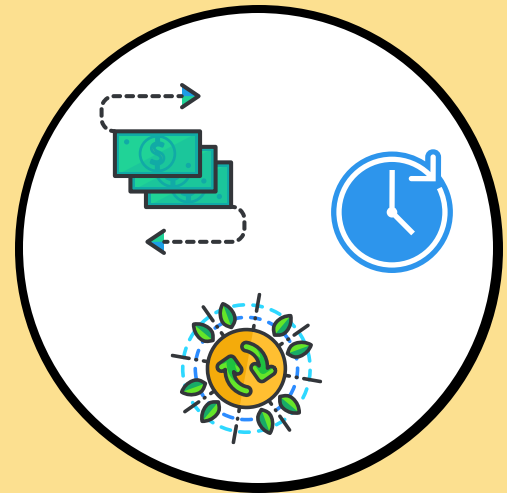

Step 1: Select Product & Partnership

- Liquid fertilizer for crop application
- Biochar for soil amendment
- Dry organic fertilizer.



Valley Sanitary District Sustainable Biosolids Management Project



Step 2: Project Design

- Identify site location
- Determine energy use and sources
- Design system for current and future needs
- Environmental and permit processes
- Community engagement

Step 3: Construction

- Continue current process during construction
- Engage local farmers and potential product users
- Run system in parallel with current process
- Dismantle outdated process after test phase completed



Step 4: Regional Expansion

- Approach local agencies for partnerships
- Develop regional partnerships through word-of-mouth and industry presentations
- Expand product availability outside of Coachella Valley

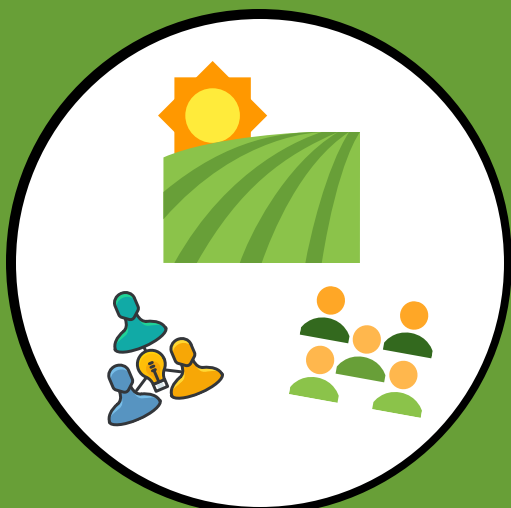



Valley Sanitary District, California

Biosolids Management Solution

Lystek 
Nothing wasted.
Everything to gain.

Valley Sanitary District, California

Biosolids Management Solution

Prepared For:

Beverli Marshall

Valley Sanitary District
45500 Van Buren Street
Indio, California, 92201

Prepared By:

Lystek International
1014 Chadbourne Road
Fairfield, California, 94534

226-444-0186
888-501-6508

Contact Person:

Jim Dunbar, P.E.
General Manager, Fairfield OMRC
Business Development Manager, Western
US
707-419-0084
jdunbar@lystek.com

Submitted: July 27, 2022



July 27, 2022

Beverli Marshall
General Manager
Valley Sanitary District
45500 Van Buren Street
Indio, CA 92201

Subject: **Concept Proposal for Biosolids Management Solution**
 Beneficial Use Services for Dewatered Biosolids

LYSTEK INTERNATIONAL (Lystek) is pleased to submit the enclosed concept proposal in response to a request from Valley Sanitary District (VSD). This concept is to assist VSD management and staff in evaluating options for advanced treatment of biosolids and beneficial uses for biosolids-derived end products.

The California-based Lystek team has over 100 years of combined working knowledge of biosolids and residuals management as well as transportation logistics. The Lystek company was founded more than 20-years ago and has since grown into North America's leading provider of Thermal Hydrolysis Process solutions for the beneficial and sustainable management of biosolids and organics. We currently service over 55 biosolids/residual generators in our mutual effort to maximize resource recovery at each step of the operations. Our efforts to date have resulted in over 1.8-million tons of beneficial use end products being sold as a high-value agricultural soil amendment – benefiting farmers and ranchers. The award-winning Lystek system reduces costs, volumes and green-house gas emissions (GHG's) by converting municipal and industrial wastewater biosolids into a high-value, nutrient-rich biofertilizer (LysteGro®). Lystek has been providing high-quality services to the wastewater community in the San Francisco Bay Area since 2016 and has processed over 250,000 wet tons of biosolids since operations were initiated. Lystek's personnel have the expertise, experience, and ability to support the goals of VSD in evaluating viable options related to biosolids solutions.

The enclosed Lystek concept proposal includes the following:

- Technical Proposal which describes the type of technology that will be used to process, store and/or reuse the biosolids. General requirements include the management options, operating schedule, and capacity of the plant. Operating characteristics include the process methods, equipment, operating and contingency plans, and overview of permitting, environmental or regulatory restrictions.
- Team Organization and Qualifications describes the qualifications of Lystek and experience in performing similar work in size and scope.
- Financial Information including content indicating the financial strength of the Company

Lystek's goal since we began operations is to meet the challenges in moving forward to comprehensive biosolids solutions for the next generation. Our concept proposal is prepared with the belief that a cooperative partnership will result in the best possible solutions **technological – economical – performance** for Valley Sanitary District. This is based on the successful record that Lystek has built over the last 20+ years, including the 6+ years at the Fairfield, California facility. It is Lystek's desire to be a long-term partner with Valley Sanitary District as the management of biosolids becomes increasingly subject to regulations and restrictions on traditional practices.

In 2013, a Water Environment Federation (WEF) workshop report stated *"due to concerns with pathogens and odors, there is a distinct shift away from Class B land application and towards more advanced, Class A treatment options."* By requesting this concept proposal, the **Valley Sanitary District is taking a leadership and pro-active role in the safe management of biosolids by specifying a reuse in a beneficial way, producing a usable product, and/or usage of biosolids in an environmentally sound manner**, and ensuring that organic resources, such as biosolids, are utilized for sustainability and productive uses in local/regional markets.

Please feel free to contact me if there are any questions or follow-up requests.

Sincerely,

James E. Dunbar, P.E.
General Manager
LYSTEK INTERNATIONAL LIMITED
1014 Chadbourne Road
Fairfield, California 94534
707-419-0084
jdunbar@lystek.com

Attached: Concept Proposal

TABLE OF CONTENTS

1	Introduction	1
2	About Lystek	2
3	Proposed Lystek Solution for the Valley Sanitary District	4
	3.1 Project Benefits	5
	3.2 Lystek THP®	5
	3.3 Integration of the Lystek Module.....	6
	3.4 Process Description	7
	3.5 LysteMize Enhanced Digestion	7
	3.6 Greenhouse Gas Impacts	9
	3.7 System Operations.....	9
	3.8 Product Storage.....	10
	3.9 Major Equipment List.....	10
4	Product Management	11
	4.1 LysteGro® Class A Biosolids.....	12
	4.2 Marketing and Sales.....	13
5	Quotation.....	14
	5.1 Lystek THP Technology and Equipment Supply	14
	5.2 LysteGro® Management Fee	15
6	Summary.....	15

LIST OF FIGURES

Figure 2-1	Map of Lystek’s California customers	4
Figure 3-1	Lystek Process Flow Schematic.....	6
Figure 3-2	Lystek LY10 Module installed with dewatered biosolids storage tank (left) and Lystek THP Reactor (right)	7
Figure 3-3	LysteMize Refeed Process Flow	8
Figure 3-4	LysteMize Storage Process Flow.....	8
Figure 3-5	Product Storage Location	10
Figure 4-1	Examples of LysteGro Hauling and Application Equipment.....	12

LIST OF TABLES

Table 3-1	Project Assumptions	5
Table 3-2	Estimated Processing System Operating Parameters	9
Table 3-3	Proposed Equipment List for each LY10 Module	11

LIST OF APPENDICES:

- Appendix A – Lystek Installations
- Appendix B – Case Studies
- Appendix C – Lystek THP Product and Service Offering
- Appendix D – Why Choose Lystek THP
- Appendix E – Conceptual Drawings
- Appendix F – EPIC Digestion/Co-Generation Demonstration Project
- Appendix G – Technical Specifications Sheet
- Appendix H – Advantages of LysteGro

1 INTRODUCTION

The Valley Sanitary District was founded in 1925 and is governed by the California Sanitary Act of 1923. The District is a California Special District governed by a locally elected Board of Directors and is located in central Riverside County to serve primarily the City of Indio and limited surrounding areas. The VSD is planning to evaluate alternative solutions for biosolids management for the wastewater treatment plant in Indio. Presently, biosolids being produced are stored onsite. The previous practice of transportation of dewatered biosolids to remote sites for land application has been stopped due to cancelation of service provider contracts.

We understand that VSD has implemented anaerobic digestion as a part of its biosolids management process and plans to add an additional digester in the near future. This will allow for energy recovery (in the form of biogas production) and reduced overall solids management quantities. Biogas produced from the digester on site is currently being flared. An evaluation of post-anaerobic digestion solutions could allow for energy recovery (with digestion enhancement) and production of Class A quality biosolids-derived end products. This would ensure biosolids are managed in a sustainable way that has the capacity to meet the area's growing population. To meet this objective, we propose the implementation of a **Lystek THP® process** to treat VSD's biosolids and produce a concentrated liquid fertilizer, **LysteGro®**, while at the same time providing opportunities for green energy production with **LysteMize®**.

The Lystek team offers an unparalleled depth and breadth of experience in designing, constructing, and operating advanced biosolids resource recovery solutions. Our multi-disciplinary engineering team has a proven track record of delivering award-winning resource recovery facilities. We are pleased to provide this opportunity for VSD to build a reputation as an innovative regional leader in sustainability with a forward-thinking biosolids program. Our technology is proven, scalable and simple to operate and maintain while providing long-term solutions for biosolids management. Lystek is a Canadian owned company with its United States operations headquartered in California. We have more than 20 years of experience as the leaders in biosolids and organics management in North America.

One System. Multiple Benefits.

- ✓ Production of a **saleable fertilizer** – LysteGro providing a local resource to the agricultural community
- ✓ Comprehensive **fertilizer management services** with revenue sharing
- ✓ Operational advantages associated with a **liquid product**
- ✓ **Production of additional biogas** with LysteMize digestion for use on-site and potential off-site sale of green energy

We are excited to offer our proven Thermal Chemical Hydrolysis Process: Lystek THP. This technology leverages an innovative and proprietary combination of thermal, chemical, and physical processes to transform biosolids into a concentrated liquid fertilizer, LysteGro, at low life cycle costs compared to alternatives. Lystek THP has a small footprint and is modular and



scalable allowing for future growth. Lystek technology offers significant financial and environmental benefits including reduced greenhouse gas emissions and operational complexity. The technology is flexible and can accept a variety of feedstock materials including undigested and digested biosolids at a range of solids concentrations. We are flexible in our implementation approach and have experience with a variety of options including: DBOO (design, build, own, operate), DBT (design, build, transfer), and TES (Technology and Equipment supply) deployments of our solution.

VSD is an excellent geographic location for LysteGro fertilizer production and distribution. The LysteGro product is registered with the California Department of Food and Agriculture as a bulk fertilizer which is an acknowledgement of its commercial value as a high-nutrient fertilizer. We have significant demand for LysteGro from our customers in northern California and believe that this interest exists in close proximity to Indio. We sell more than 100,000 tons (25,000,000 gallons) of LysteGro annually in northern California, with demand continuing to outpace supply. With recent commercial fertilizer supply issues and price increases, VSD can play a significant role in assisting with the security of agricultural production in the region. In addition to this, implementing Lystek technology will contribute positively to GHG reduction while producing a valuable product for local farmers and allow for the potential to generate revenues and off-set operating expenses for VSD rate-payers.

Our approach and technology represent a proactive leading-edge solution that meets or exceeds current regulations. As part of our approach to partnering with agencies, we are pleased to offer our comprehensive LysteGro management service including product marketing and best practice use to provide VSD with program compliance, stability, and peace of mind. As VSD approaches its 100-year anniversary of existence, this would serve as an excellent opportunity to showcase its vision for a safe and secure future.

The details of this solution, including equipment specifications, operating parameters, and conceptual layout, are described below.

2 ABOUT LYTEK

Lystek is North America's leading provider of Class A thermal hydrolysis solutions for biosolids and organics management. We continue to grow at an ever-increasing rate, despite challenges the biosolids and organics management sector is facing. We remain independent and focused on providing technical and operational excellence to our partners and clients. If we need expertise outside of our core businesses, we team with experienced companies that provide synergies, not distractions, to meet our project goals and objectives. Lystek has successfully and sustainably scaled our operations across new geographical markets by growing our substantial in-house capabilities and developing strong industry relationships. We collaborate effectively with project teams to put the most effective offering forward to our customers. Lystek

- ✓ **Over 55 generators serviced**
 - ✓ **17 Lystek THP Modules operating world-wide**
 - ✓ **4 NEW facilities in design / construction**
- Over 1.8 Million tons of LysteGro biosolids produced and sold**



maintains long standing relationships with senior leaders in the engineering and consulting sectors to keep our operations at the forefront of technology advancement. We work in partnership with municipalities, wastewater treatment plants, and private sector clients to recover valuable nutrients from biosolids and other organic feedstocks.

Development of the patented [Lystek THP®](#) process began in 1998, spearheaded by industrial microbiologists at the University of Waterloo. Leveraging this strong foundation, and a consistent commercial growth trajectory, our organization now provides resource recovery solutions to more than 55 utilities world-wide, with more being added each year.

We service a range of small, medium, and large generators with both on and off-site solutions.

Our Canadian operations commenced in 2000 and deployment of Lystek technology currently services utilities such as Toronto, Guelph, Hamilton, and many others. Our Canadian flagship site, the Southgate Organic Materials Recovery Center (OMRC), is a large regional organics processing centre with an annual operating capacity of 165,000 wet tons. It has serviced over 30 Ontario generators since opening in 2013. Our flagship facility in the U.S., the Lystek Fairfield OMRC, is co-located at the Fairfield-Suisun Sewer District (FSSD) in California. Commissioned in 2016, this regional facility has the capacity to process 150,000 wet tons of biosolids and organic residuals annually. This facility receives digested and undigested third-party residuals from customers including the FSSD as well as outlying communities such as San Francisco, Santa Rosa, Petaluma, and Palo Alto. From 2016 when the facility opened until 2021, the facility has received and processed over 250,000 wet tons of biosolids, commercial organic sludges, and food/beverage organic liquids. This facility produces a Class A biosolids fertilizer that is beneficially applied to local land in an environmentally sound manner. A portion of the processed product is also designed to be recirculated through the FSSD's anaerobic digesters for volatile solids reduction and to optimize biogas production for energy recovery.

Our in-plant installations, such as in St. Cloud, MN, and Centre Wellington, ON, are fully integrated with the existing WWTP solids processing. These installations offer on-site, easy to-operate solutions that are economical and offer long-term program security. Our locations serviced in California can be seen below in [Figure 2-1](#).

See [Appendix A](#) for a summary of our installations and [Appendix B](#) for project case studies.





Figure 2-1 Map of Lystek’s California customers

We are committed to long-term partnerships with our customers and leverage our expertise to offer comprehensive technology, design-build, product management, and communications and engagement support.

Lystek’s management team offers proven national and international experience in the wastewater, organics, agriculture, and waste management industries to implement our technology and aid in developing long-term solutions.

In addition to wastewater generated biosolids, Lystek can receive waste/sludges from the food and beverage commercial sector. This type of material can be used in Lystek technology to capture the same benefits of organic nutrients in the final LysteGro product. Two feedstocks worth highlighting are waste sludges from the Budweiser Brewery (in Fairfield) and expired liquid concentrate from Blue Pacific Flavours (also in Fairfield). The Budweiser dewatered sludge is received daily (approximately 1,000 wet tons annually) and the Blue Pacific Flavours liquids are received in bulk on an as requested basis.

Lystek believes in the concept of maintaining locally developed resource recovery for local uses. We believe it is important to deliver resources to local users and offset the need for remote industrialization of chemical or hydro-carbon based fertilizers.

3 PROPOSED LYTEK SOLUTION FOR THE VALLEY SANITARY DISTRICT

We understand that the Valley Sanitary District is experiencing challenges related to year-round space for drying and service providers for the transportation of biosolids. In light of this, we propose the implementation of Lystek technology. In doing so, the Valley Sanitary

District can transition to a proven, sustainable, and long-term solution for biosolids management while creating a Class A biosolids fertilizer.

This proposed solution has been developed using the assumptions noted in [Table 3-1](#).

Table 3-1 Project Assumptions









Predicted biosolids generation rate:	1,135 dry tons/year
Operating hours per year:	2,080 (8 hours/day, 5 days/week)
LysteGro Class A fertilizer per year:	7,567 wet tons (assumed 15% solids)

*We propose one **LY10 THP Module** to meet the projected needs of the Valley Sanitary District.*

Note: the module has been sized to have a duty load of no more than 80% capacity.

3.1 PROJECT BENEFITS

Lystek THP will achieve multiple benefits for the Valley Sanitary District including:

-  Improvement of operational efficiencies.
-  Modular and flexible system allowing for expansion in processing capacity to accommodate future flows.
-  Production of Class A biosolids fertilizer LysteGro.
-  Comprehensive fertilizer management services with revenue sharing opportunities for the VSD.
-  Cost effective, sustainable fertilizer source for the agricultural community.
-  Operational advantages associated with a liquid product.
-  Fully automated and easy to operate system.
-  The ability to produce additional biogas for beneficial reuse on site.

3.2 LYSTEK THP®

Lystek THP is a unique, thermal-chemical hydrolysis process employing high-speed shearing, alkali, and low-pressure steam injection. The technology can process organic feedstocks to produce a multi-purpose, hydrolyzed product.

This process provides operational flexibility. Lystek THP has multiple product uses, including **LysteGro®** Class A biosolids fertilizer, **LysteMize®** digester enhancement process, and **LysteCarb®** alternative carbon source. The benefits associated with implementing this system and our comprehensive service offering are outlined in [Appendix C](#).

For a comparison of the differences and similarities between Lystek THP and alternative Class A biosolids processing and management options see [Appendix D](#).



3.3 INTEGRATION OF THE LYTEK MODULE

We propose the Lystek THP Module is incorporated at the end of the solids treatment train at the Valley Sanitary District in Indio, California.

Additional dewatering equipment to ensure biosolids enter the reactor at greater than 15% solids may be required. This will ensure the system is cost effective and allow the plant to realize the benefits of reduced residual volumes. The process flow schematic is outlined below in Figure 3-1. The dewatering equipment can be placed directly above the biosolids storage hopper, which reduces material handling capital and operating costs. This represents a significant avoided cost in conveyors, piping, and truck loading facilities. Dewatering equipment can be sourced and installed directly by the Valley Sanitary District or Lystek is experienced and can incorporate dewatering into the final design if requested.

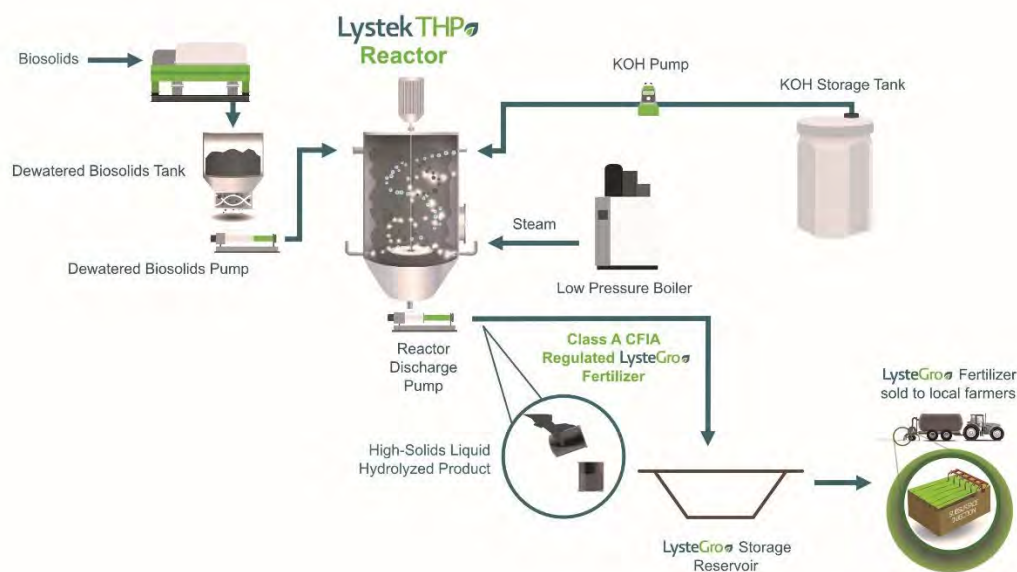

Figure 3-1 Lystek Process Flow Schematic

A conceptual facility layout has been included (Appendix E) to demonstrate the compact and modular nature of the Lystek THP system.

Note that this layout is a conceptual starting point and can be adapted to alternate geometries in order to suit the available real estate. We have experience integrating our system with both new builds and retrofitting existing infrastructure to accommodate the overall footprint.

The overall footprint is approximately 1,600 square feet for one LY10 Module.

In addition to the system as described above, an odor treatment system may need to be implemented due to the proximity of the plant to both residential and commercial areas. We are capable and willing to discuss options, expected costs, and our experience with odor control should it be determined that it should be implemented at this site.

3.4 PROCESS DESCRIPTION

Dewatered biosolids, ideally in the range of 16-18% TS, are fed into the dewatered biosolids storage tank and then pumped using progressive cavity feed pumps into the Lystek Reactor (see [Figure 2](#) for example installation).

Lystek THP technology requires feedstock at lower solids content compared to existing operations and other Class A treatment technologies, which will result in polymer cost savings. We have proven this approach in past projects with vendors such as Andritz, GEA, Alfa-Laval, and BDP as key project partners.

Within the Reactor, the combination low-pressure steam, potassium hydroxide (an agronomically valuable chemical), and physical shearing transform the material into a homogenized and pumpable high-solids content, liquid product.

The Reactor operates at atmospheric pressure and is insulated to reduce heat loss during processing and stand-by times. The Reactor operates in a semi-continuous mode, meaning that the Reactors are regularly filled to their working capacity while steam, alkali, and shear are applied. Following the confirmation of temperature and hold criteria to meet USEPA Class A biosolids requirements, the finished product, LysteGro, is discharged to storage on a continuous operating cycle to maximize the throughput of the system. The product is stored between application seasons. The newly processed material has a solids content in the range of 13-16% but has the physical properties of a low-solids liquid product that can be handled using conventional liquid pipes, pumps, and application equipment.

The characteristics and benefits of LysteGro biosolids fertilizer are outlined in detail in [Section 5](#) below along with an overview of our Product Management Services offering.

3.5 LYSTEMIZE ENHANCED DIGESTION

Should Valley Sanitary District wish to produce additional biogas on site, there is opportunity to do so with a LysteMize program using the hydrolyzed material produced from the same Lystek THP Module. This will have an added benefit of increasing volatile solids destruction and further reducing the residual volumes requiring management offsite.

The implementation of Lystek THP can increase the processing capacity of existing digesters by several mechanisms:

- 1) Particle size reduction, feedstock homogenization, and viscosity reduction due to treatment by Lystek THP can improve mixing dynamics in anaerobic digesters, which can improve digester kinetics.



Figure 3-2 Lystek LY10 Module installed with dewatered biosolids storage tank (left) and Lystek THP Reactor (right)



- 2) Lystek THP solubilizes carbon that would go otherwise undigested in anaerobic digesters creating additional biogas and eliminating solids.
- 3) Owing to product homogeneity, highly solubilized carbon, and enhanced activity, the hydrolyzed substrate will generate renewable biogas faster than unhydrolyzed material.

LysteMize can be implemented in either a refeed configuration or a storage configuration. In a refeed configuration as seen in [Figure 3-3](#) below, a portion of the hydrolyzed product is returned to the digester for additional degradation. In the storage configuration as seen in [Figure 3-4](#) below, the fertilizer storage tank roof is modified to create a fully anaerobic environment, which enables anaerobic digestion. Due to the nature of the hydrolyzed material from Lystek THP, there is no heating or mixing requirement to generate biogas in this configuration.

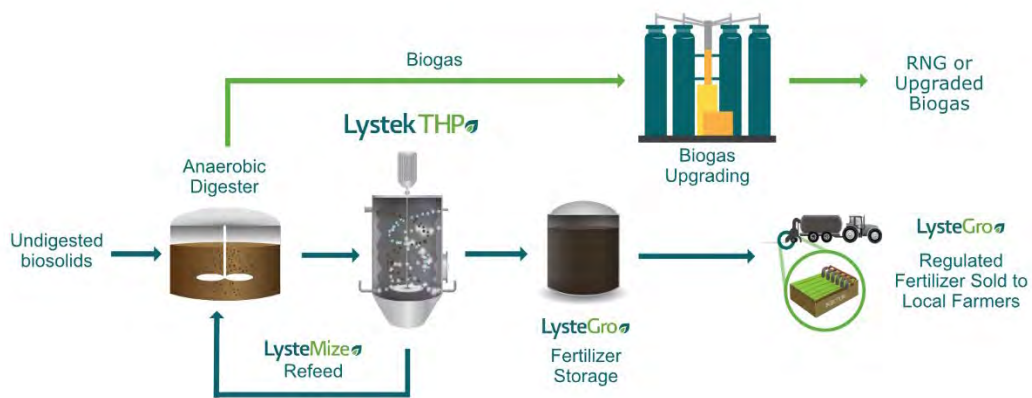

Figure 3-3 LysteMize Refeed Process Flow

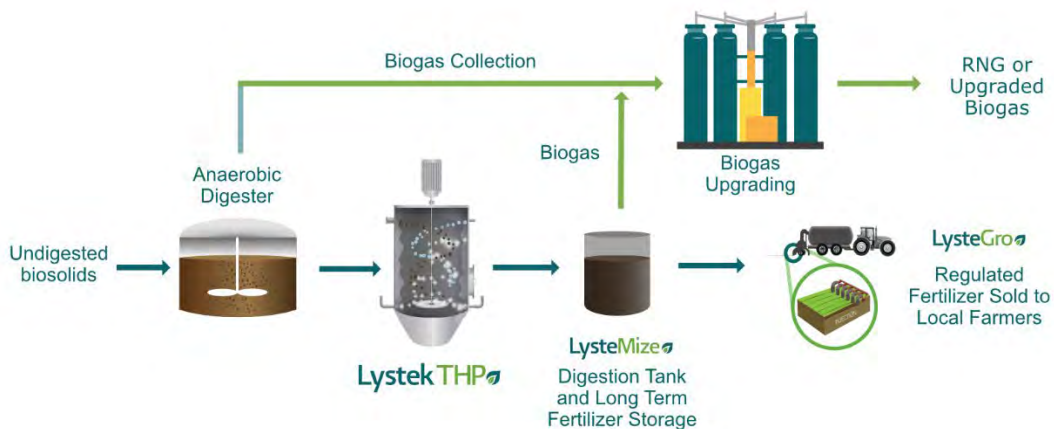

Figure 3-4 LysteMize Storage Process Flow

Information outlining an example of refeeding Lystek processed material into anaerobic digesters in Goleta, California can be found in [Appendix F](#).

3.6 GREENHOUSE GAS IMPACTS

Beneficial use of biosolids consistently allows for a smaller carbon footprint than other disposal oriented biosolids management practices. Land applying biosolids sequesters carbon in the soil and provides further GHG offsets with the replacement of synthetic nitrogen and phosphorous fertilizers. Considerations when comparing various land application programs include factors such as the finished product concentration, distance travelled to field, energy input associated with processing, chemical inputs, and application methods.

Lystek THP goes beyond the benefits of conventional land application, providing advanced treatment to transform biosolids and residuals into a high-quality concentrated liquid Class A US EPA-registered fertilizer in a very energy efficient manner. The process optimizes the energy inputs required for treatment and transportation of residuals by operating at a higher solids concentration, while maintaining the liquid properties of the material: essential for efficient processing, conveyance, transportation, and land application.

The only chemical addition in the treatment process, KOH, provides a beneficial addition of potassium to the fertilizer, and therefore offsets the use of mined potassium by the farmers.

Further GHG reductions could be realized by integrating the LysteMize process at the Valley Sanitary District to enhance biogas production.

While the exact mass of CO₂-equivalent GHGs avoided depends entirely on site specific processing and management conditions, we have always found our LysteGro operating scenarios to present net negative GHG emissions.

The major benefits of Lystek THP are centred on the liquid advantage, providing advanced treatment with an energy efficient process. Liquid processing is simple from an operational perspective, saves on processing costs, provides significant health and safety advantages, and benefits the overall fertilizer value (retaining the soluble nutrients), optimizing efficiencies, and GHG reduction.

3.7 SYSTEM OPERATIONS

Due to the highly automated and easy to operate nature of the system, minimal staff intervention is required. Under typical conditions operators need only monitor the system in the event of an alarm notification. This approach has been proven and confirmed throughout our existing in-plant deployments.

The processing parameters associated with this system are noted in [Table 3-2](#).

Table 3-2 Estimated Processing System Operating Parameters

Electrical consumption for processing	Average 60 kW-h per dry ton
Heat requirements for processing	Average 1,100,000 BTU per dry ton ¹
50 w/w% caustic potash solution	Average 170 lb per dry ton ²
Operating temperature set point	167°F / 75°C
Solids content – LysteGro product	13 - 16%
Viscosity – LysteGro product	6,000 – 10,000 cP



¹Dependent upon biosolids feed temperature into the Lystek Reactor

²Estimated based on average dosing rates for digested feedstock

Further information detailing the operating inputs of the Lystek THP solution can be found on the attached Technical Specifications Sheet, provided as [Appendix G](#).

3.8 PRODUCT STORAGE

Once the biosolids have been processed and transformed into LysteGro, they are pumped into enclosed storage. The material is stored in a contained environment to maintain product quality for our agricultural customers.

We have experience with above or below ground tanks, steel or concrete, retrofitting existing liquid storage tanks, as well as lined and covered reservoirs. Based on a previous site visit, we recommend an above-ground storage tank be placed in the area that is currently the concrete-lined basin used for drying solids on the East side of the facility as shown in the yellow circle in [Figure 3-5](#) below.



Figure 3-5 Product Storage Location

The concentrated and homogenous nature of the Class A biosolids fertilizer will provide the Valley Sanitary District with the operational security and flexibility they desire. Further, the homogenous nature of LysteGro eliminates the need for any decanting, mixing, aeration, or cleanout activities in the storage tanks and the capital and operational costs associated with this.

Given the land application seasonality typical for the region, we recommend the installation of a minimum of three months storage on site. While the exact tank dimensions will depend on design requirements, the outline represents what a 40 foot diameter tank would look like on site.

3.9 MAJOR EQUIPMENT LIST

We recommend one LY10 Lystek THP Module to meet the Valley Sanitary District in Indio's projected biosolids processing needs with operations completed in a 40-hour week. Redundancy will be achieved with extended operating hours.

Each Module includes the Lystek THP Reactor as well as the associated pumps, tanks, and supporting auxiliary systems. Listed below in Table 3-3 is the major elements associated with the proposed system.

Table 3-3 Proposed Equipment List for each LY10 Module

Element	Quantity	Function
Dewatered Biosolids Tank	1	Receives and stages dewatered biosolids from dewatering equipment
Dewatered Biosolids Pump	1	Progressive cavity pump feeds the Reactor
Lystek THP Reactor and Disperser	1	Transforms biosolids into CFIA regulated LysteGro biosolids fertilizer
Reactor Discharge Pump	1	Positive displacement pump transports LysteGro fertilizer from the Reactor to the LysteGro Storage
KOH Storage Tank	1	Double walled storage tank to store KOH solution
KOH Pump	1	Doses KOH solution to Reactor
Boiler	1	Low pressure boiler (<15 PSI) provide steam heat to the Reactor

As mentioned above, if additional dewatering or odor treatment equipment are determined to be required, the equipment list will be updated to reflect such changes.

4 PRODUCT MANAGEMENT

Part of our overall strategic approach is to provide a turnkey product and service offering to our customers. This includes management of the LysteGro product and all associated costs. Our team effectively manages large and small-scale LysteGro sales and application programs across North America.

Our team has the experience and expertise needed to develop and manage an effective and professional fertilizer marketing and application program for the region surrounding the Valley Sanitary District in the Indio, California area.

This section will provide an outline of the benefits of producing Class A biosolids and the approach we will use to manage the LysteGro marketing, sales, and distribution.

The Lystek THP system transforms biosolids and residuals into a Class A biosolids product that is pathogen free and in high demand.

4.1 LYSTEGRO® CLASS A BIOSOLIDS

The Lystek THP system transforms biosolids and residuals into a pathogen free, Class A biosolids product that is in high demand by the end customer. *LysteGro meets all criteria for Class A biosolids as classified by the US EPA.* This system and our product management methods have been designed and proven to maximize the value of the LysteGro for both the agricultural customer and utility.



Figure 4-1 Examples of LysteGro Hauling and Application Equipment.

LysteGro is a valuable fertilizer with proven performance as a commercial fertilizer replacement with predictable nitrogen, phosphorus, and potassium (NPK) values. LysteGro is pathogen-free, concentrated and remains fully pumpable with conventional liquid handling and application equipment. In addition to the macronutrient value, LysteGro is beneficial to farmers for several reasons, specifically:

Cost Savings: We market LysteGro to farmers at an affordable price based on the macronutrient content of the material. Notably, LysteGro biosolids fertilizer contains added Potassium (K), a key nutrient that is present in only very low quantities in other biosolids, providing significant value to the farmer. Benefits of LysteGro application are realized over multiple years due to the slow-release nature of the nutrients in the product and improvements in soil health.

Micronutrients: Micronutrients important for crop growth, including calcium, sulfur, zinc, copper, and several others inherent in biosolids, provide the farmer with an affordable option for these nutrients that are expensive to purchase in the commercial fertilizer form. The value of micronutrients in LysteGro is not factored into the fertilizer pricing to the farmer, so this is an added benefit.

Organic matter: The addition of organic matter to soils will help to improve overall soil health, including improved water holding capacity, soil structure and tilth, increased microbial activity as well as increased resilience to severe weather conditions.

Lystek technology proudly makes use of 100% of the biosolids as feedstock to produce this award-winning fertilizer: there are no liquid or solid sidestreams from the Lystek processing technology. Lystek obtained registration of its end product as bulk fertilizer from the California Department of Food and Agriculture in 2016. Since opening the OMRC facility, Lystek has received approval from Solano, Yolo and Colusa Counties for year-round unrestricted LysteGro to be beneficially used without constraints imposed on traditional biosolids-based materials.

LysteGro is subsurface injected to increase soil contact, ensure maximum nutrient use efficiency, and mitigate odors and run-off potential. The in-field aesthetics and cleanliness of the injection operation that we employ is superior to alternative surface application methods. The liquid nature of LysteGro allows for loading and off-loading efficiencies as well as odor mitigation at the plant and throughout transportation.

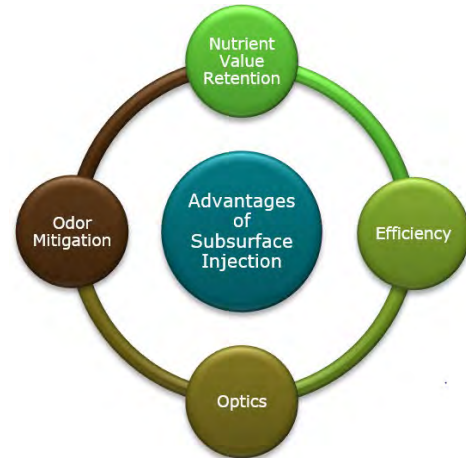

The advantages of producing a high-solids liquid product and our approach to product management are described further in [Appendix H](#).

We will work with local and regional farmers, ranchers, and contractors to ensure LysteGro is hauled and applied based on our internal best management practices.

These requirements meet state and federal regulations for Class A biosolids and incorporate best management practices that are standard for the agricultural industry.

Since our first commercial scale plant was built in 2008, more than 1.8 million tons of LysteGro fertilizer has been produced. During that time, **Lystek has never landfilled any sludge, biosolids, or other organic residuals that were intended for processing at one of our commissioned facilities.** As a result, **we have sold and land applied every single ton of fertilizer we manage**, a record we are exceptionally proud of.

It is also well known that global supplies of phosphorus, a key ingredient in the manufacture of chemical fertilizers, are being rapidly depleted. There is therefore a role for Valley Sanitary District to play in helping to ensure that organic resources, such as biosolids, are beneficially utilized for agricultural sustainability.

4.2 MARKETING AND SALES

We have developed a proven and successful marketing program for LysteGro in North America. We are capable and willing to assume full responsibility for the fertilizer distribution program at the Valley Sanitary District in Indio and are currently performing this service for most of our customers.

The combination of our cost-effective technology and our ability to provide back-end product management offers a turnkey service to our customers. This full-service approach sets us apart from alternative technology providers.

We have invested significant resources into developing a professional product management team and the resources required to facilitate this. We employ agricultural professionals (Certified Crop Advisors, Professional Agrologists, etc.) who have an educational background

in environmental science and as a result, we understand and focus on both the needs of our agricultural customers and the importance of environmental stewardship.

*We have sold over
1,800,000 tons of LysteGro
in North America!*

To date, we have sold all LysteGro fertilizer (over 1,800,000 tons) we manage, and we intend to do the same with the product produced at the Valley Sanitary District.

With commercial fertilizer prices and demand for organic amendments from the agricultural sector expected to increase, the value of LysteGro fertilizer will continue to rise over time and have greater value to customers. This represents a built-in hedge against future rising management prices.

Over the next 20 years, these market trends will continue as society continues to prioritize resource recovery, soil health, and sustainability.

In summary, our approach to product management is to ensure that the material is handled and applied in the most effective manner possible to optimize the value of the material while also engaging the local agricultural community to demonstrate product value. This long-term strategy is proven to effectively develop a stable market of loyal customers who understand the value of the product and are willing to pay for it.

"After my first application of LysteGro, I saw immediate results in my pasture crop as compared to my field without the product. The Lystek staff are very accommodating to my schedule and easy to work with. The application equipment used was effective and had no negative impact on my existing operation."

Ryan Mahoney, Rio Vista Rancher

With Lystek as its partner, the Valley Sanitary District would have the option to leverage our proven successful approach or simply request our assistance, where required, to manage the product.

5 QUOTATION

5.1 LYSTEK THP TECHNOLOGY AND EQUIPMENT SUPPLY

Based on our current understanding of the needs of Valley Sanitary District in Indio, California we are pleased to offer one LY10 module a (equipment supply and technology licence) for one LY10 Module with accessories: **US \$ 2,785,000**

This is a preliminary estimate that would require additional information from the Valley Sanitary District for confirmation. The cost accounts for the technology licence, mechanical and electrical equipment, and software associated with the Lystek THP LY10 Module and is contingent on the project assumptions. This cost does not include installation, LysteGro storage, interconnect wiring and piping, utility connections, freight, or integration of the Lystek SCADA system into the overall facility SCADA. Additional dewatering equipment and odor control equipment may also be required as discussed previously in the proposal. These components would result in additional line items and an adjusted quotation from what is listed above.



This quotation is provided based on commodity and material pricing at the time of proposal delivery and is valid for 90 days.

The quoted price in this proposal has been calculated based on the current market prices required to manufacture the quoted equipment and services pursuant to regulations, duties and law in effect as of the date of this proposal. In the event that the introduction of new tariffs, levies, duties, regulations, or any type of legislation by a domestic or foreign government has the effect of increasing the price of the quoted equipment or services, Lystek reserves its right to adjust its quoted price in order to reflect these increases in cost. Nothing in this document or in any of the applicable contractual documentation shall be construed as a waiver of this right.

5.2 LYSTEGRO® MANAGEMENT FEE

This full-service offering includes all marketing, sales, hauling, and regulatory reporting requirements of the product. We ensure that all local, state, and federal regulations are adhered to along with Lystek's industry leading best management practices.

With more time to fully evaluate the potential market, we would be able to provide an accurate range for our expected LysteGro Management Fee. Should discussions progress on this opportunity, we will fully evaluate the market in the Indio, California area in order to provide a firm and accurate price.

Revenue Sharing Agreement

As part of the management contract for LysteGro, we will also offer a revenue sharing agreement to the Valley Sanitary District. Any revenue paid by the farmer for the product over and above an agreed upon selling price will be shared 50/50 between the Valley Sanitary District and Lystek. Revenue sharing allows the Valley Sanitary District to directly benefit from the production of a high-quality Class A biosolids fertilizer.

6 SUMMARY

We thank you for the opportunity to propose a Class A biosolids processing and management solution for the Valley Sanitary District in Indio, California.

This approach will enhance Valley Sanitary District existing biosolids management operations with a sustainable Class A biosolids program that will offer program security and economic stability and continue to recover the valuable nutrients found in these residuals. Our comprehensive program will be part of this sustainable and forward-thinking transition to a long-term solution. This solution can effectively meet and manage the Valley Sanitary District's current biosolids as well as being scaled to meet future needs.

This offer also includes comprehensive product management services to develop a long-term biosolids program in the region and ensure best-practice use of LysteGro. This offers Valley Sanitary District a hands-off, worry-free, and sustainable solution.

We look forward to working with the Valley Sanitary District to address their biosolids management challenges with an advanced, Class A solution that will be a model in the Region.

This will enhance resource recovery, operational and management efficiencies on site, and will set the Valley Sanitary District up for a sustainable solution that can easily accommodate increased flows or regulatory changes.

Thank you for your consideration. We look forward to future discussions.



Jim Dunbar, P.E.
Business Development Manager
707-419-0084
jdunbar@lystek.com



Alex West, P.Eng
Senior Engineer, Project Manager
519-807-4952
awest@lystek.com



APPENDICES

Appendix A

Lystek Installations

Location (Commissioned)	Pop.	Volumes Currently Processed (DT/Y) ^{1,2}	Site Installation Details	Module Size	Feedstock	Lystek Products/ Processes	LysteGro Storage
Guelph, ON (2008)	132,000	2,500	On-Site - Retrofit	2 - LY6	Anaerobic Digested Biosolids	LysteGro, LysteMize	Modular Transportable Above Ground Storage Tanks
St. Marys, ON (2010)	7,300	240	On-Site - Retrofit	LY3	Originally: Anaerobic Digested Biosolids Current: Aerobic Digested Biosolids	LysteGro, LysteMize, LysteCarb	Below Ground Concrete Tank
Elora, ON (2014)	7,500	130	On-Site - Retrofit	LY6	Aerobic Digested Biosolids	LysteGro	Below Ground Concrete Tank
North Battleford, SK (2014)	14,300	490	On-Site - Retrofit	LY6	Aerobic Digested Biosolids	LysteGro	Retrofitted Reservoir – Lined & Covered
St. Thomas, ON (2018)	41,800	1,500	On-Site - New Build	LY6	Undigested Residuals	LysteGro	Above Ground Tank
St. Cloud, MN (2018)	120,000	1,500	On-Site - Retrofit	LY10	Anaerobic Digested Biosolids	LysteGro	Repurpose - Below Ground Concrete Tank
Innisfil, ON (2019)	36,500	555	On-Site - New Build	LY3	Aerobic Digested Biosolids	LysteGro	Retrofit - Above Ground Tank with Floating Cover
Goleta, CA (2019)	N/A	Demo / R&D	On-Site - Skid Unit	N/A	Source Separated Organics (UC Santa Barbara), Biosolids (Goleta Sanitary District)	LysteMize	N/A
South Huron Valley, MI (2022)	87,000	1,950	On-Site - Retrofit	LY10	Undigested Biosolids	LysteGro	Below Ground Concrete Tank

Location (Commissioned)	Pop.	Volumes Currently Processed (DT/Y) ^{1,2}	Site Installation Details	Module Size	Feedstock	Lystek Products/ Processes	LysteGro Storage
Sharjah, UAE (2022)	1.4 M	1,240	Off-Site – Container Module	LY3	Aerobic Digested Biosolids	LysteGro	N/A
Commerce Township, MI (Coming Soon!)	44,000	480	On-Site Retrofit	LY10	Undigested Biosolids	LysteGro	Above & Below Ground Concrete Tanks
Erin, ON (Coming Soon!)	12,000		On-Site	LY10	Undigested Biosolids	LysteGro LysteMize	Above Ground Steel Tanks

¹Approximate current volumes processed in dry metric tonnes per year

²Current site processing dependent upon hours of operation and regulated processing rates

**Customer references available upon request*

Regional Installations

Location (Commissioned)	Module Size	Site Capacity (WT/Y) ¹	Site Details	Deployment Structure	Lystek Products/ Processes	Feedstock	LysteGro Storage
Southgate, ON (2012)	3 – LY10	165,000	Off-Site - Regional Facility, Greenfield	DBOO	LysteGro	Undigested / Digested Biosolids & Organics from Various Municipalities	Reservoirs – Lined & Covered
<p>Serving generators such as:</p> <ul style="list-style-type: none"> - Toronto, Halton, Hamilton, Kitchener, Guelph, Niagara, Orangeville, Tay Township, West Grey, Gravenhurst, Peterborough, Huntsville, Mississauga, Brantford, Arthur, Innisfil, Meaford, Owen Sound, Midland, Walkerton, Centre Wellington, Mono, Biox Ltd. 							
Iroquois, ON (2012)	1 – LY10	45,000	Off-Site - Regional Facility Upgrade	DBT	LysteGro	Undigested / Digested Biosolids from Various Municipalities	Below Ground Concrete Tank
<p>Serving generators such as:</p> <ul style="list-style-type: none"> - Ottawa, Toronto, Peterborough, among others 							
Fairfield, CA (2016)	2 – LY10	150,000	On-Site - P3 Regional Facility	P3 - DBOO	LysteGro, LysteMize	Undigested / Digested Biosolids from Various Municipalities	Reservoir – Lined & Covered
<p>Serving generators such as:</p> <ul style="list-style-type: none"> - Fairfield-Suisun Sewer District, City and County of San Francisco, East Bay Municipal Utility District, Santa Rosa, Central Marin Sanitation Agency, Petaluma, Benicia, Palo Alto, City of South San Francisco, Budweiser Brewing in City of Fairfield 							

¹Site capacity represented in wet tons (average 15% TS) per year

*Customer references available upon request

Appendix B

Case Studies

Addition of Lystek THP Extends Storage and Reduces GHG Emissions

Town of St Marys, Ontario

Lystek
Nothing wasted.
Everything to gain.



St. Marys wanted to be at the forefront of wastewater treatment technology.

ABOUT

St. Marys is a Town located about 40 kilometers north of London, Ontario in Perth County, with a population of approximately 7,200 residents. www.townofstmarys.com

CHALLENGES

- Regulatory guidelines increased to require additional on-site biosolids storage capacity (240 days) for wastewater treatment plants
- Increasing costs for biosolids management
- Desire to improve environmental performance of existing plant facilities

SOLUTION

St. Marys WWTP selected Lystek THP as an advanced biosolids treatment technology, providing these benefits:

- Dramatic reduction in biosolids volumes and adherence to new regulatory guidelines for biosolids storage without adding new tanks

- Ability to develop an integrated sludge management plan, tying together biological nutrient removal (BNR), anaerobic digestion and Lystek THP to optimize nutrient recovery and reduce greenhouse gas (GHG) emissions
- Production of a Canadian Food Inspection Agency (CFIA, or Class A) regulated fertilizer from biosolids for use on local farmland
- Flexibility in process – Lystek THP produces fertilizer from digested or undigested sludges

RESULT

- Reduced biosolids volumes by up to 75%
- Optimized BNR process and anaerobic digestion, when operational
- Production of (Class A) biosolids fertilizer, even after removal of anaerobic digesters
- More than **15,000 tonnes** of fertilizer sold and applied to local farmland



KEY METRICS

Population Served: 7,200

WWTP Rating: 5,560 m³ / day (1.5 MGD)

Lystek THP Processing Footprint: 74 m² (800 ft²)

Lystek THP Module Size: 1 x LY3 (0.3 dry tons / hr)

Feedstock: Municipal biosolids (aerobically digested)

In 1990, the St. Marys wastewater treatment plant (WWTP) began operating with primary and secondary conventional activated treatment followed by anaerobic digestion of sludge. Digested biosolids were applied as a soil amendment to surrounding agricultural land from April to November. This non-agricultural source material (NASM or Class B) was stored over the winter.

Storage capacity at the WWTP became a concern when the Nutrient Management Act was amended in 2007, recommending 240 days of biosolids storage by 2009. With a maximum influent processing capacity of 5,560 m³ per day, the on-site storage capacity only provided about 90 days of storage.

In response to this and increasing influent volumes at the plant, the Town of St. Marys retained their engineering firm, GHD (formerly Conestoga Rovers and Associates) to evaluate alternative sludge management strategies at the plant. Ultimately, GHD recommended the town implement a management strategy that integrated BNR, anaerobic digestion, and Lystek THP, "We believed this combination would provide the town with the most cost effective solution when both capital investment and lifecycle costs are considered," confirmed Andrew Lugowski, P.Eng., Associate at GHD.

The Lystek system offered multiple benefits to the Town's wastewater process and biosolids management, including:

- Reduced biosolids volumes by concentrating the solids (dewatering to produce a 10-15% liquid compared with previous 3% solids NASM)
- Optimization of both biological nutrient removal and anaerobic digestion processes through re-feeding of Lystek-processed product (LysteCarb & LysteMize), further reducing biosolids volumes and improving efficiencies
- Production of a CFIA regulated fertilizer product from biosolids, which is sold to local farmers

Lystek THP was implemented at the St. Marys WWTP in 2012. Both the LysteMize and LysteCarb re-circulation options were implemented to enhance the BNR and

anaerobic digestion processes at the plant. Ultimately, the WWTP was able to increase the capacity of the existing storage tanks from 90 days to 300 days.

In 2015, the anaerobic digestion process was taken offline due to required infrastructure repairs. Lystek THP was able to continue processing biosolids at the WWTP that were not anaerobically digested and meet the same quality parameters for use as a fertilizer product (Class A biosolids). The Town elected to save cost on repairs to their digester, and continue operations without digestion, leaving Lystek THP as its primary biosolids process option.

Overall, implementation of Lystek THP at the St. Marys WWTP provided the Town with a stable and secure biosolids processing and management program. This technology extended capacity, life and optimizing various treatment processes, all while producing a saleable fertilizer (Class A biosolids) product. To date, the town has recycled more than 15,000m³ of LysteGro fertilizer produced from biosolids to local farmland.



About Lystek

Lystek is a leading provider of Thermal Hydrolysis solutions for the sustainable management of biosolids and organics. The multi-use, award-winning Lystek system reduces costs, volumes and GHG's by converting municipal and industrial wastewater treatment facilities into resource recovery centers. The technology transforms organic waste streams into value-added products and services, such as the patented LysteMize[®] process for optimizing digester performance, reducing volumes and increasing biogas production; LysteGro[®], a high-value, nutrient-rich fertilizer and LysteCarb[®], an alternative source of carbon for BNR systems.

Retrofit Creates Sustainable Biosolids Management Solution

Fairfield-Suisun Sewer District, California

Lystek
Nothing wasted.
Everything to gain.



Fairfield-Suisun Sewer District enters into a unique Public-Private Partnership (P3) with Lystek to bring first, comprehensive biosolids management solution to the San Francisco Bay Area.

ABOUT

Located about 40 miles north-east of San Francisco, the Fairfield-Suisun Sewer District (FSSD) services over 135,000 people and operates 70 miles of sewer, with 13 pumping stations within 48 square miles in central Solano County.

www.fssd.com

CHALLENGES

- High and rising costs for biosolids management; diversion from landfill required
- Regulatory pressures to move towards higher treatment and beneficial use
- Under-utilized assets and spacious site
- Lack of coordinated biosolids management solution for the Bay Area

SOLUTION

The Fairfield-Suisun Sewer District entered into a 20 year (+10) public-private partnership (P3) agreement with Lystek International Ltd. to develop a regional Organic Material Recovery Center (OMRC), implementing Lystek THP under a design-build-own-operate model, providing these benefits:

- Long term sustainable biosolids management solution with extended program security
- Production of a high-quality Class A biosolids product, registered as a bulk fertilizer with the California Department of Food and Agriculture (CDFA)
- Generate revenue and local jobs; establish a regional solution for other Bay Area utilities

RESULT

- Currently providing biosolids management solutions to more than 10 Bay Area utilities
- More than **250,000 tons** (as of 2021) of biosolids converted into fertilizer and applied to local farms
- Increased biogas generation through the LysteMize process



KEY METRICS

WWTP Rating (FSSD): 5,000 m³ / day (23.7 MGD)

Population Served: 135,000

Lystek OMRC Annual Capacity: 150,000 tons

Lystek THP Module Size: 2 x LY10

Lystek THP Processing Footprint: 2,500 sq ft.

Feedstock: Municipal biosolids (anaerobically digested, aerobically digested, undigested), anaerobically digested organic waste products, organic-based liquid materials and processed food-grade wastes

The FSSD oversees wastewater treatment and sanitary sewers in northern California's Solano County. Prior to engaging with Lystek, the District had been sending their biosolids to landfill for use as daily cover for decades. In the early 2010s, regulatory changes began to address organic materials in landfills, and it was clear that the State would be requiring biosolids to be diverted from landfills to beneficial use. In addition, the San Francisco Bay Area expressed the need to develop regional solutions for biosolids management.

FSSD has had a long history of looking for innovative solutions for its wastewater treatment program. In 2015, the District and Lystek International developed a public-private partnership (P3) project on-site at the FSSD wastewater treatment plant (WWTP). The partnership agreement allowed the development of the Fairfield Organic Material Recovery Center (OMRC) as a regional biosolids and organics management facility, owned and operated by Lystek, leveraging under-utilized infrastructure and assets at the FSSD plant. This facility became operational in 2016, for a duration of 20 years, with a 10-year optional extension.

The OMRC accepts organic residuals year round, produces a fertilizer product, **LysteGro®** using our patented Lystek THP technology, and stores the Class A fertilizer product onsite during inclement weather periods. LysteGro is sold and applied to agricultural soil throughout the year, as field conditions allow. The material is classified as a Class A biosolids by USEPA (Part 503 standards) and has received a bulk fertilizer registration by the California Department of Food and Agriculture (CDFA). This dual-designation has allowed LysteGro to be widely used and accepted by area farmers and ranchers as an alternative to synthetic fertilizers. The use of LysteGro is now accepted in multiple counties which have historically been restrictive to traditional Class B biosolids and land application practices.

The other major opportunity of the FSSD-Lystek partnership involves enhanced digestion and biogas generation. FSSD operates anaerobic digesters to treat wastewater solids and utilize the biogas for onsite co-generation (electricity plus heat for the digesters). This practice reduces the overall plant energy dependence on fossil-fuels sources. Through the LysteMize process, a portion of the Lystek THP hydrolyzed material can be re-fed to anaerobic digesters to increase volatile solids destruction and boost biogas yields. The LysteMize process began operations in 2019 at FSSD, refeeding processed biosolids from FSSD and third party generators to the digesters. Due to new California legislation related to organics diversion from landfills, generators of undigested biosolids who send their material to the OMRC are able to obtain diversion and recycling credits for the volumes processed with the use of the Lystek technology and enhanced digestion.

This successful P3 partnership between FSSD and Lystek has offered Bay Area agencies a reliable, sustainable and cost-controlled biosolids management solution. Generators now have a convenient resource recovery facility which produces and manages a Class A biosolids fertilizer and is capable of reducing GHG emissions through additional biogas recovery in the FSSD digesters. The successful LysteGro management program has sold and applied more than 350,000 tons (as of 2021) of CDFA registered fertilizer, and is in demand from area farmers and ranchers.



About Lystek

Lystek International, founded in 2000, is the leading provider of advanced, thermal hydrolysis solutions in North America, with operations Globally. Lystek is a full-service company offering technology supply and installation services, worry-free regional processing solutions, and comprehensive LysteGro sales and management services. Lystek THP® is proven across a range of small, medium, and large communities. We work with public and private sector clients to enhance operations, reduce GHG emissions, and recover valuable nutrients and carbon from biosolids and organic feedstocks through the production of increased renewable biogas with LysteMize® and LysteGro® Class A quality biosolids fertilizers.

Appendix C

Lystek THP Product and Service Offering

ABOUT LYTEK INTERNATIONAL

Lystek was founded in 2000 at the University of Waterloo, in Ontario Canada and is owned by the Tomlinson Group. We are a multi-award-winning organics processing and management company, with locations across North America.

Lystek has proven this technology and service offering across a range of small, medium, and large communities in North America. We work with public and private sector clients to enhance operations and recover valuable nutrients from biosolids and other organic feedstocks.

We work with our customers as long-term partners. Owning and operating our own facilities allows us to conduct ongoing commercial-scale research and development. In doing so, we continuously optimize our technology and processes to realize operational improvements. As part of our commitments to our customers, we share these enhancements to maximize their investment in the Lystek solution.

"It was unreal, how easy the deployment of this system was. This, combined with the small footprint, low cost and excellent support from the Lystek team - it was almost like the system was designed especially for our facility."

Stewart Schafer, Director of Utility Services, City of North Battleford



WHAT WE OFFER

Design-Build-Transfer, Technology & Equipment Supply

We have extensive experience working with generators and consulting engineers to design and build a solution that is ideal for each facility.

We have deployed our technology as new builds as well as retrofitted our Modules into existing infrastructure.

We are equipped to provide complete design-build-transfer services for generators looking to implement Lystek THP. We are also comfortable supplying our technology as part of a broader team.

Regional Solutions

We own and operate large regional Organic Material Recovery Centres (OMRCs) in Fairfield, California and the Township of Southgate, Ontario.

The OMRCs receive digested & undigested material (1-35% TS) from generators in the region. These facilities produce Class A quality biosolids fertilizer that is sold to the local agricultural market for beneficial use.

Contact us for more information about having your residuals processed at these facilities.

Comprehensive Product Management

We offer comprehensive product management services assuming full responsibility for the LysteGro fertilizer program for our in-plant installations.

Utilities can take comfort in knowing their biosolids are handled according to industry best management practices.

The combination of our cost-effective technology and product management service provides a turnkey solution our customers are satisfied with.

This full service approach sets us apart from technology vendors.

Lystek



Nothing wasted.
Everything to gain.

One System Multiple Benefits for Biosolids & Organics Management

Lystek THP® is an innovative and award-winning resource recovery solution with multiple benefits for biosolids and organics management.

Lystek's unique, physical-chemical thermal hydrolysis process uses a combination of high speed shearing, alkali, and low pressure steam in an enclosed Reactor to transform digested or undigested biosolids and/or organics into a multi-purpose hydrolyzed product.

The process disintegrates microbial cell walls and hydrolyzes complex macromolecules into simpler and readily biodegradable compounds. This provides operational flexibility, with multiple uses for process optimization and resource recovery:

-  LysteGro® Class A Biosolids Fertilizer
-  LysteMize® Anaerobic Digester Optimization
-  LysteCarb® Alternative Carbon Source

This process transforms dewatered feedstocks, ideally in the range of 16 - 18% total solids, into a high-solids (13-16%) liquid product with a viscosity below 10,000 centipoise. This product is fully pumpable using traditional liquid processing, handling, and application equipment.

The system has a small footprint and is simple to operate, modular, and flexible. Lystek THP can be easily integrated into existing WWTPs typically at the end of the solids process train, with little to no disruption to other WWTP processes.

This process can be deployed as an on-site or off-site solution (regional facility) and is scalable to service small, medium, and large residual generators.

Due to the user friendly and easy to operate nature of Lystek THP, typically no additional operators are needed beyond existing staff and no specialized operator certifications are required.



BENEFITS:

-  Recovers valuable nutrients & organics
-  Energy efficient process
-  Easy to operate and maintain, with no additional operators required
-  Small processing footprint with ability to retrofit into existing infrastructure
-  Comprehensive product management services
-  Processes digested or undigested residuals
-  Mitigates odors with an enclosed system
-  Integrates easily with multiple resource recovery technologies

"Use of this proven technology and development of this project is playing an important role in capping operational expenses related to biosolids management. It also allows us to diversify our resource recovery options by leveraging existing, under-utilized infrastructure to generate additional revenues, further offsetting costs"

Greg Batruup, General Manager,
Fairfield-Suisun Sewer District



One System. Multiple Uses.

Lystek THP provides operational flexibility. By installing one THP Module, utilities can produce Class A quality biosolids fertilizer (LysteGro) and have the flexibility to recirculate the hydrolyzed material to enhance anaerobic digester performance (LysteMize) or be used as a supplemental carbon source for BNR (LysteCarb). This technology optimizes full-cycle resource recovery.

LysteCarb Alternative Carbon

Carbon is required to facilitate the removal of both Nitrogen (N) and Phosphorous (P) in biological nutrient removal (BNR) systems. When WWTPs do not have sufficient organic carbon in their incoming wastewater, a consistent, supplemental source of carbon is used to ensure reliable performance.

Lystek hydrolyzed biosolids can be used as a safe, cost-effective alternative carbon source. We call this product LysteCarb®. Not only does LysteCarb contain a much higher COD:N:P ratio than raw wastewater, but the material is also much higher in concentrations of readily biodegradable COD (SCOD). This product can thereby replace costly conventional chemicals such as methanol, glycerol, or acetic acid.

When recycled in BNR systems, LysteCarb provides readily available carbon for denitrification and Enhanced Biological Phosphorus Removal (EBPR).

Simply put, LysteCarb offers enhanced BNR system operations with a safer, cost effective source of carbon for enhanced biological denitrification and phosphorous removal. This process also reduces residual volumes requiring management.

LysteCarb and LysteMize Characteristics	
Soluble Chemical Oxygen Demand (SCOD)	40-50%
Total Chemical Oxygen Demand (TCOD)	105,000 - 150,000 mg/L
Volatile Fatty Acids (VFA)	10,000 - 15,000 mg/L

LysteMize Digester Optimization

Lystek THP solubilizes organic compounds, making the digested residuals more amenable to further biodegradation when re-fed to anaerobic digesters (AD). This is referred to as LysteMize®.

Lystek's hydrolyzed product contains 40-50% of the TCOD as SCOD, and significantly increased VFAs versus typical biosolids.

The addition of this substrate to the digester allows for quicker conversion to biogas. This not only improves the biodegradability of organic compounds in the hydrolyzed product that were not digested in the first pass through, but also enhances overall digester kinetics.

LysteMize enhances biodegradation of volatile solids by up to 20% and can increase biogas yields by up to 40%. This optimizes resource recovery and further minimizes residuals requiring management offsite.

LysteGro Biosolids Fertilizer

Lystek THP's cornerstone product is a pathogen free, high-solids liquid fertilizer product, called LysteGro®. LysteGro meets the US Environmental Protection Agency's (EPA) criteria for a Class A biosolids and the Canadian Food Inspection Agency's (CFIA) criteria for a registered fertilizer.

Growers value LysteGro because of the predictable NPK values, organic matter, soil incorporation and, most importantly, the fertilizer's performance.

Third-party studies have shown LysteGro can completely replace commercial fertilizers and result in superior crop yields.

LysteGro is injected into the soil subsurface during application to maximize nutrient use efficiency and mitigate odor and run-off potential. The in-field aesthetics and cleanliness of the injection operation that we employ are superior to surface application methods.

Our technology and product management services are proven to maximize value for both the end-user and generator. We have sold over one million tons of LysteGro, with market price continuing to rise. This rising fertilizer value can be used to offset utility's biosolids program costs.

One System. Multiple Uses.

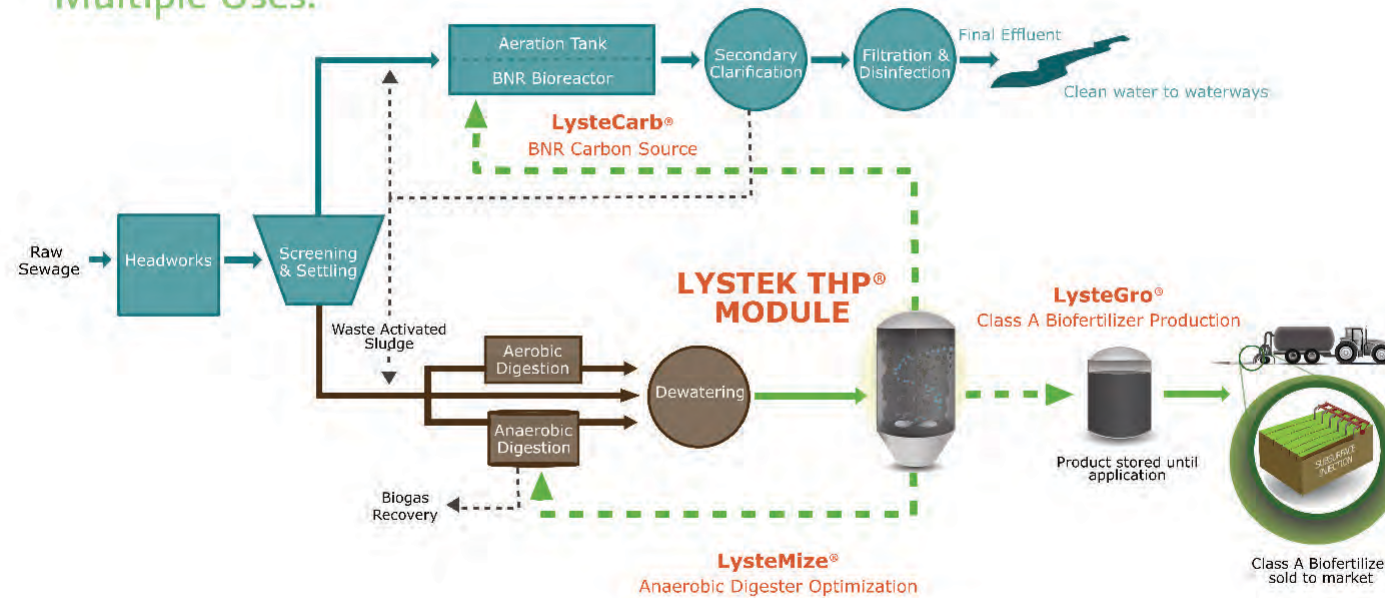

Community Fertilizer Programs

- Long-term sustainable program
- Produce a valuable fertilizer
- Good value to local farmers
- Opportunity to offset program costs
- Closing the loop between generators and local agriculture

Advantages of a High-Solids Liquid Biosolids Fertilizer

- Simple, cost effective liquid pumping and storage systems
- Transportation loading and unloading efficiencies
- Odor mitigation with enclosed system
- Efficient and cost effective land application
- Maximizes carbon and nutrient value
- Mitigates risk of runoff and enhances environmental protection
- Improves in-field aesthetics with subsurface injection
- Quality fertilizer improves yields and reduces input costs



ABOUT LYTEK INTERNATIONAL

Lystek was founded in 2000 at the University of Waterloo, in Ontario Canada and is owned by the Tomlinson Group. We are a multi-award-winning organics processing and management company, with locations across North America.

Lystek has proven this technology and service offering across a range of small, medium, and large communities in North America. We work with public and private sector clients to enhance operations and recover valuable nutrients from biosolids and other organic feedstocks.

We work with our customers as long-term partners. Owning and operating our own facilities allows us to conduct ongoing commercial-scale research and development. In doing so, we continuously optimize our technology and processes to realize operational improvements. As part of our commitments to our customers, we share these enhancements to maximize their investment in the Lystek solution.

"It was unreal, how easy the deployment of this system was. This, combined with the small footprint, low cost and excellent support from the Lystek team - it was almost like the system was designed especially for our facility."

Stewart Schafer, Director of Utility Services, City of North Battleford



WHAT WE OFFER

Design-Build-Transfer, Technology & Equipment Supply

We have extensive experience working with generators and consulting engineers to design and build a solution that is ideal for each facility.

We have deployed our technology as new builds as well as retrofitted our Modules into existing infrastructure.

We are equipped to provide complete design-build-transfer services for generators looking to implement Lystek THP. We are also comfortable supplying our technology as part of a broader team.

Regional Solutions

We own and operate large regional Organic Material Recovery Centres (OMRCs) in Fairfield, California and the Township of Southgate, Ontario.

The OMRCs receive digested & undigested material (1-35% TS) from generators in the region. These facilities produce Class A quality biosolids fertilizer that is sold to the local agricultural market for beneficial use.

Contact us for more information about having your residuals processed at these facilities.

Comprehensive Product Management

We offer comprehensive product management services assuming full responsibility for the LysteGro fertilizer program for our in-plant installations.

Utilities can take comfort in knowing their biosolids are handled according to industry best management practices.

The combination of our cost-effective technology and product management service provides a turnkey solution our customers are satisfied with.

This full service approach sets us apart from technology vendors.

Lystek

Nothing wasted.
Everything to gain.

One System Multiple Benefits for Biosolids & Organics Management

Lystek THP® is an innovative and award-winning resource recovery solution with multiple benefits for biosolids and organics management.

Lystek's unique, physical-chemical thermal hydrolysis process uses a combination of high speed shearing, alkali, and low pressure steam in an enclosed Reactor to transform digested or undigested biosolids and/or organics into a multi-purpose hydrolyzed product.

The process disintegrates microbial cell walls and hydrolyzes complex macromolecules into simpler and readily biodegradable compounds. This provides operational flexibility, with multiple uses for process optimization and resource recovery:

- LysteGro® Class A Biosolids Fertilizer
- LysteMize® Anaerobic Digester Optimization
- LysteCarb® Alternative Carbon Source

This process transforms dewatered feedstocks, ideally in the range of 16 - 18% total solids, into a high-solids (13-16%) liquid product with a viscosity below 10,000 centipoise. This product is fully pumpable using traditional liquid processing, handling, and application equipment.

The system has a small footprint and is simple to operate, modular, and flexible. Lystek THP can be easily integrated into existing WWTPs typically at the end of the solids process train, with little to no disruption to other WWTP processes.

This process can be deployed as an on-site or off-site solution (regional facility) and is scalable to service small, medium, and large residual generators.

Due to the user friendly and easy to operate nature of Lystek THP, typically no additional operators are needed beyond existing staff and no specialized operator certifications are required.



BENEFITS:

- Recovers valuable nutrients & organics
- Energy efficient process
- Easy to operate and maintain, with no additional operators required
- Small processing footprint with ability to retrofit into existing infrastructure
- Comprehensive product management services
- Processes digested or undigested residuals
- Mitigates odors with an enclosed system
- Integrates easily with multiple resource recovery technologies

"Use of this proven technology and development of this project is playing an important role in capping operational expenses related to biosolids management. It also allows us to diversify our resource recovery options by leveraging existing, under-utilized infrastructure to generate additional revenues, further offsetting costs"

Greg Batruup, General Manager,
Fairfield-Suisun Sewer District



Appendix D

Why Choose Lystek THP

WHY CHOOSE LYTEK THP®

Comparing Lystek THP to Alternative Class A Treatment Technologies



	Heat Dried Pelletized Product	Alkaline Stabilized Dry Product	Compost	High Pressure THP	Lystek THP®
OPERATING BENEFITS					
No additional operators required	✗	✗	✗	✗	✓
Does not disrupt upstream processes	✓	✓	✓	✗	✓
Small processing footprint	✗	✗	✗	✗	✓
Rapid processing time	✗	✗	✗	✓	✓
Fully enclosed system, minimal process air	✗	✗	✗	✓	✓
No potential for dust generation	✗	✗	✗	✓	✓
Digester enhancement	✗	✗	✗	✓	✓
Multiuse carbon source for nutrient removal	✗	✗	✗	✗	✓
FERTILIZER PRODUCT BENEFITS					
Market ready fertilizer	✓	✓	✓	✓	✓
High solids liquid advantage	✗	✗	✗	✗	✓
Sub-surface injected	✗	✗	✗	✗	✓
Full NPK nutrient value	✗	✓	✗	✗	✓
Suitable for precision agriculture	✓	✗	✗	✗	✓
ECONOMIC BENEFITS					
Low capital cost	✗	✗	✓	✗	✓
Fertilizer revenue sharing options	✗	✗	✗	✗	✓
Reduced dewatering polymer consumption	✗	✗	✗	✗	✓
ENVIRONMENTAL BENEFITS					
Contributing to the circular economy	✓	✓	✓	✓	✓
Reduced energy inputs	✗	✗	✓	✗	✓

Appendix E

Conceptual Drawings

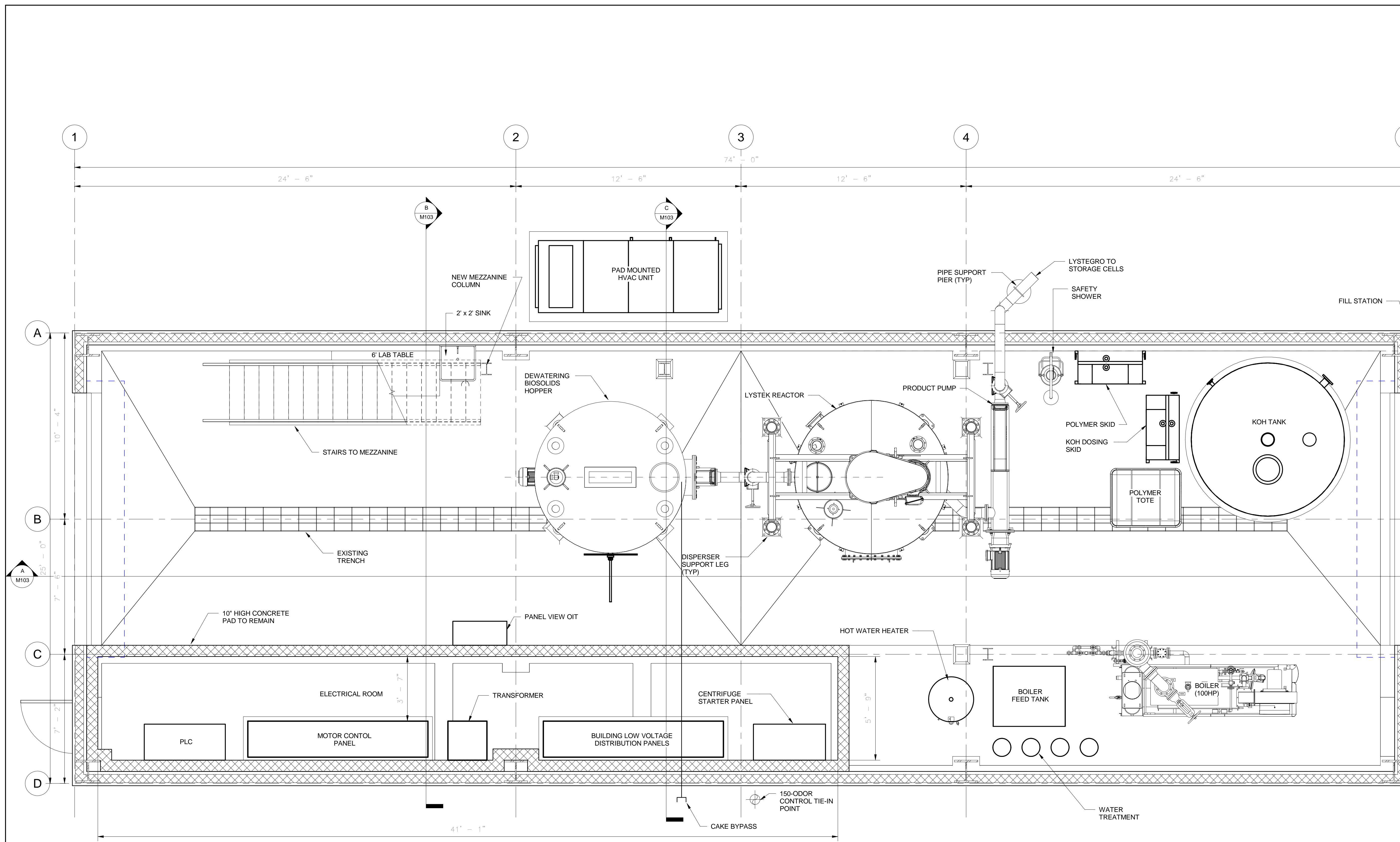

1 01-MAIN FLOOR
3/8" = 1'-0"

CONCEPTUAL

Automated Engineering Technologies Ltd.
 91A Duke Street, Guelph, Ontario N1E 5L1 (519)821-8644
 397 Romeo Street S., Stratford, ON, N5A 4V1 (519)273-9318 WEB: www.autoengtech.on.ca

No.	REVISION	DATE

APPROVED BY: _____

LYSTEK

MAIN FLOOR
LY10 ARRANGEMENT

Lystek International
 125 McGovern Drive, Unit #1
 Cambridge, Ont., Can., N3H 4R7
 Phone: 1-888-501-6508
 Fax: 1-888-501-7429
 Web: www.lystek.com

DESIGNED BY: T.P.	REVIEWED BY: M.B.	DRAWN BY: C.F.	DATE: 08/14/2020
SCALE: 3/8" = 1'-0"	PROJECT No. -	DRAWING No. M101	

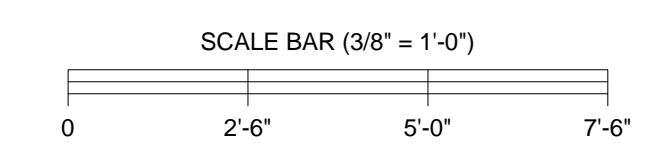

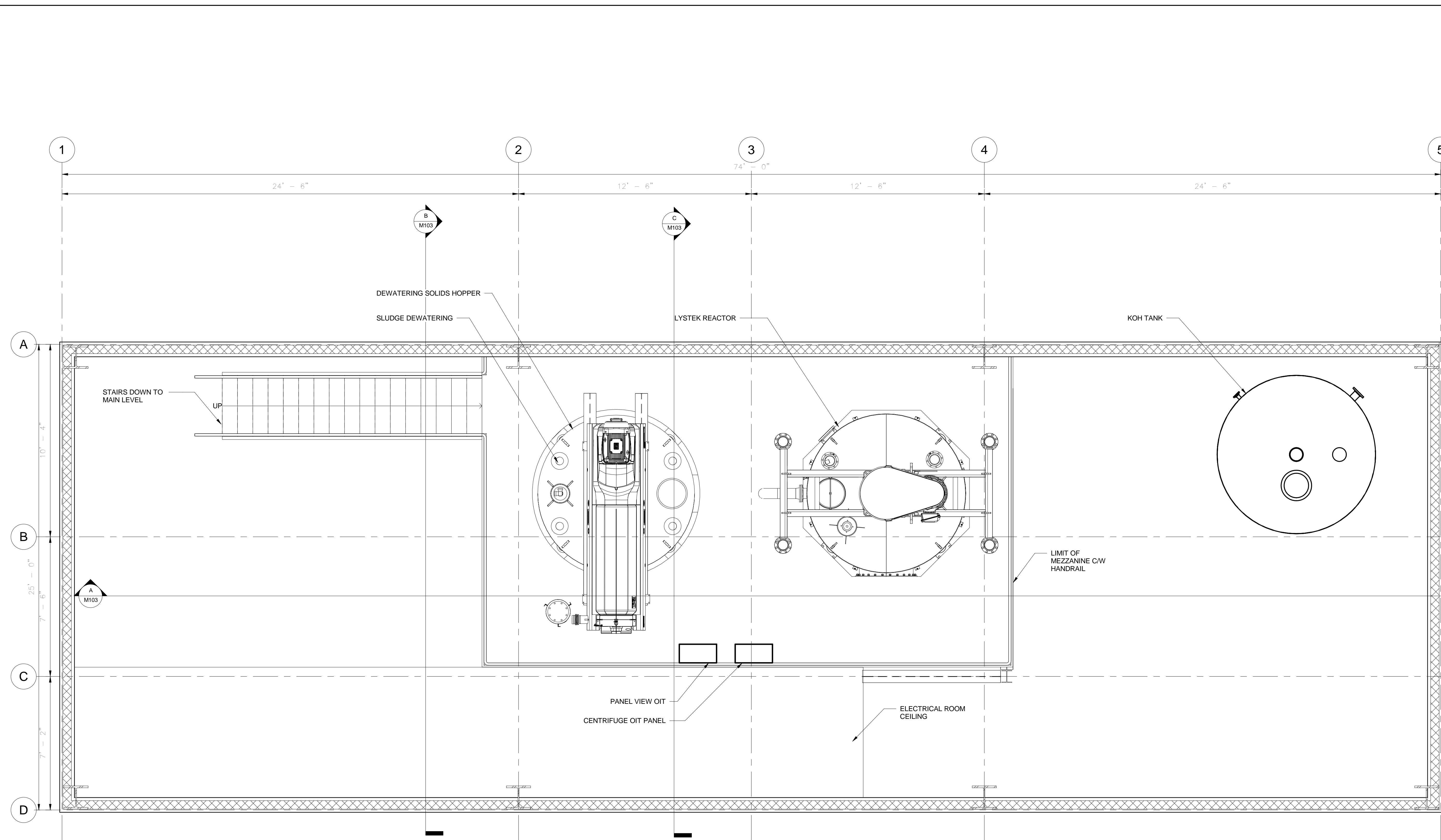

1 02-MEZZANINE
3/8" = 1'-0"

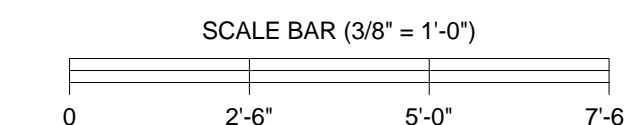

CONCEPTUAL

Automated Engineering Technologies Ltd.
 91A Duke Street, Guelph, Ontario N1E 5L1 (519)821-8644
 397 Romeo Street S., Stratford, ON, N5A 4V1 (519)273-9318 WEB: www.autoengtech.on.ca

No.	REVISION	DATE

No.	REVISION	DATE
APPROVED BY:		

LYSTEK
 LY10 ARRANGEMENT
 MEZZANINE LEVEL

Lystek International
 125 McGovern Drive, Unit #1
 Cambridge, Ont., Can., N3H 4R7
 Phone: 1-888-501-6508
 Fax: 1-888-501-7429
 Web: www.lystek.com

DESIGNED BY: T.P.	REVIEWED BY: M.B.	DRAWN BY: C.F.	DATE: 08/14/2020
SCALE: 3/8" = 1'-0"	PROJECT No. -	DRAWING No. M102	

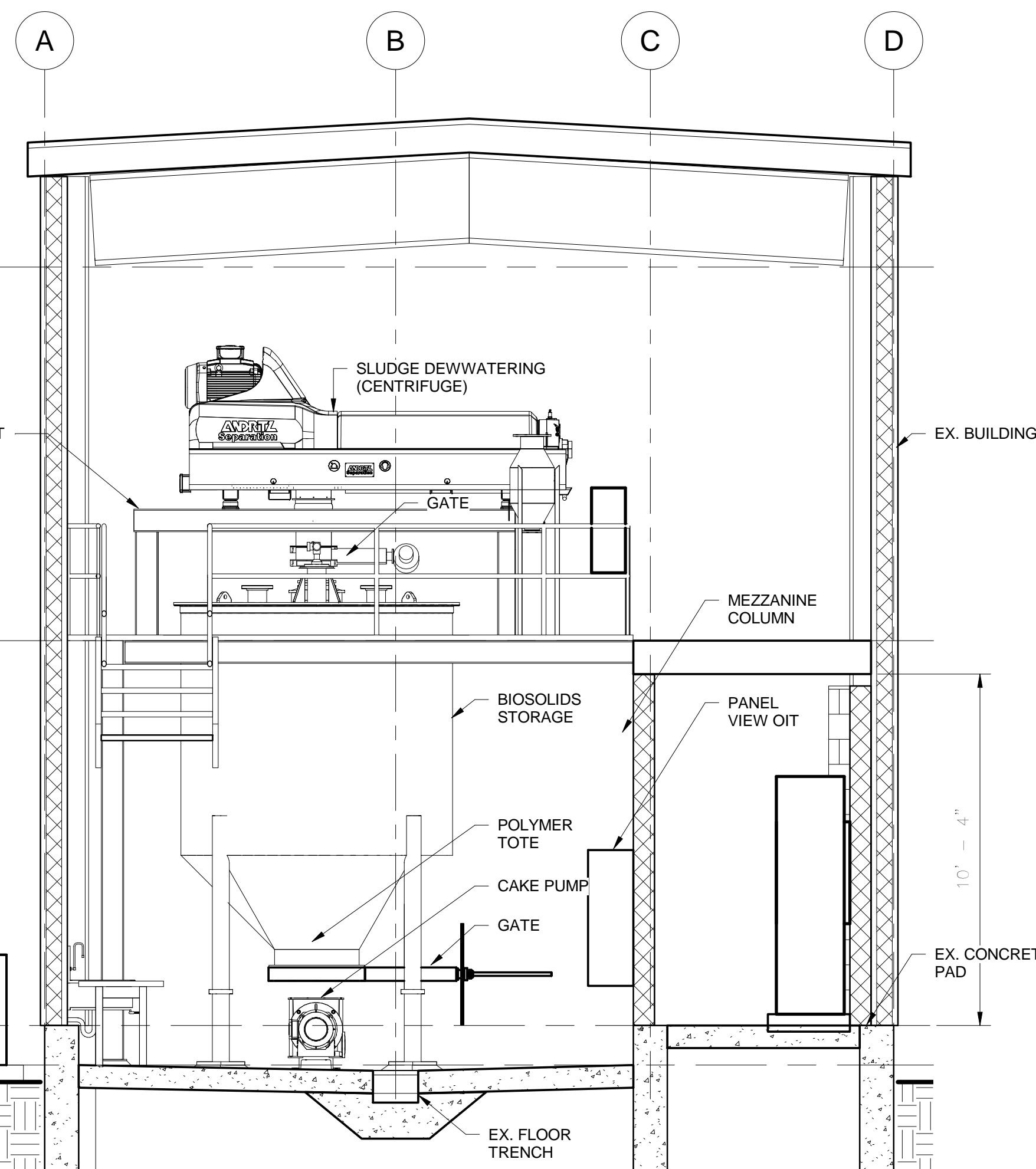
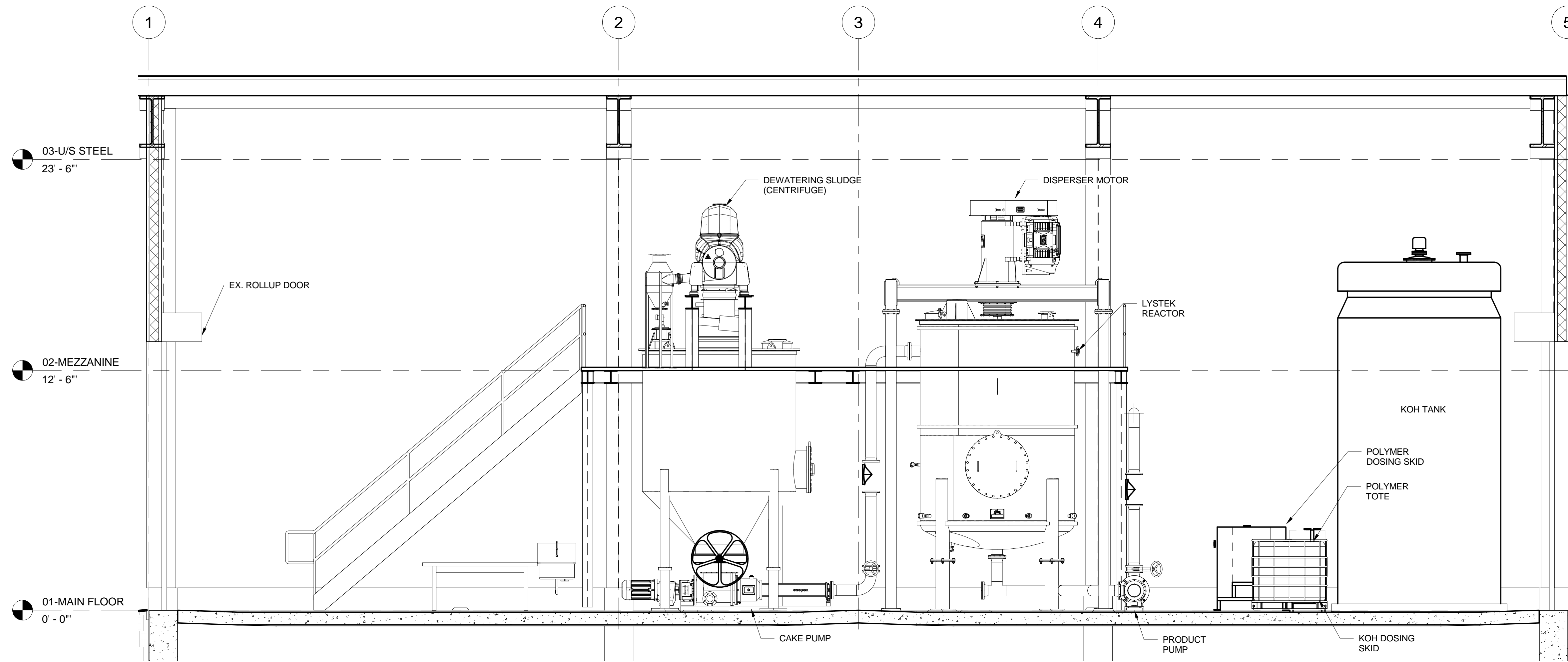

SECTION B
5/16" = 1'-0"
M101

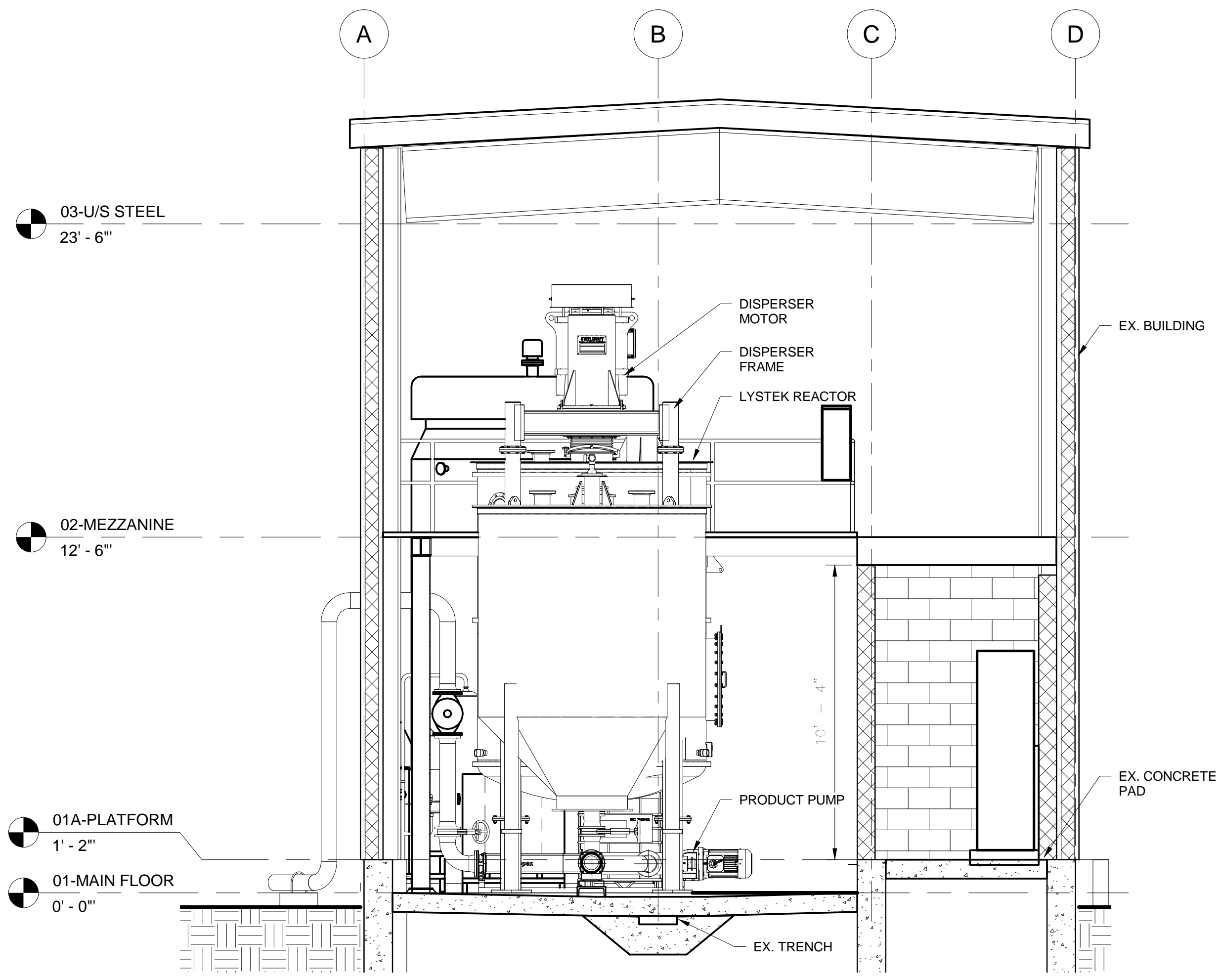

SECTION C
5/16" = 1'-0"
M101

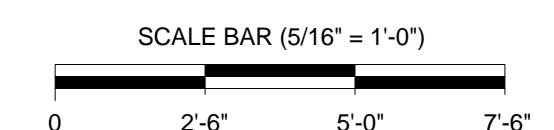

CONCEPTUAL

Automated Engineering Technologies Ltd.
 91A Duke Street, Guelph, Ontario N1E 5L1 (519)821-8644
 397 Romeo Street S., Stratford, ON, N5A 4V1 (519)273-9318 WEB: www.autoengtech.on.ca

No.	REVISION	DATE

APPROVED BY:

LYSTEK
 LY10 ARRANGEMENT SECTIONS

Lystek International
 125 McGovern Drive, Unit #1
 Cambridge, Ont., Can., N3H 4R7
 Phone: 1-888-501-6508
 Fax: 1-888-501-7429
 Web: www.lystek.com

DESIGNED BY: T.P.	REVIEWED BY: M.B.	DRAWN BY: C.F.	DATE: 08/14/2020
SCALE: 5/16" = 1'-0"	PROJECT No. -	DRAWING No. M103	

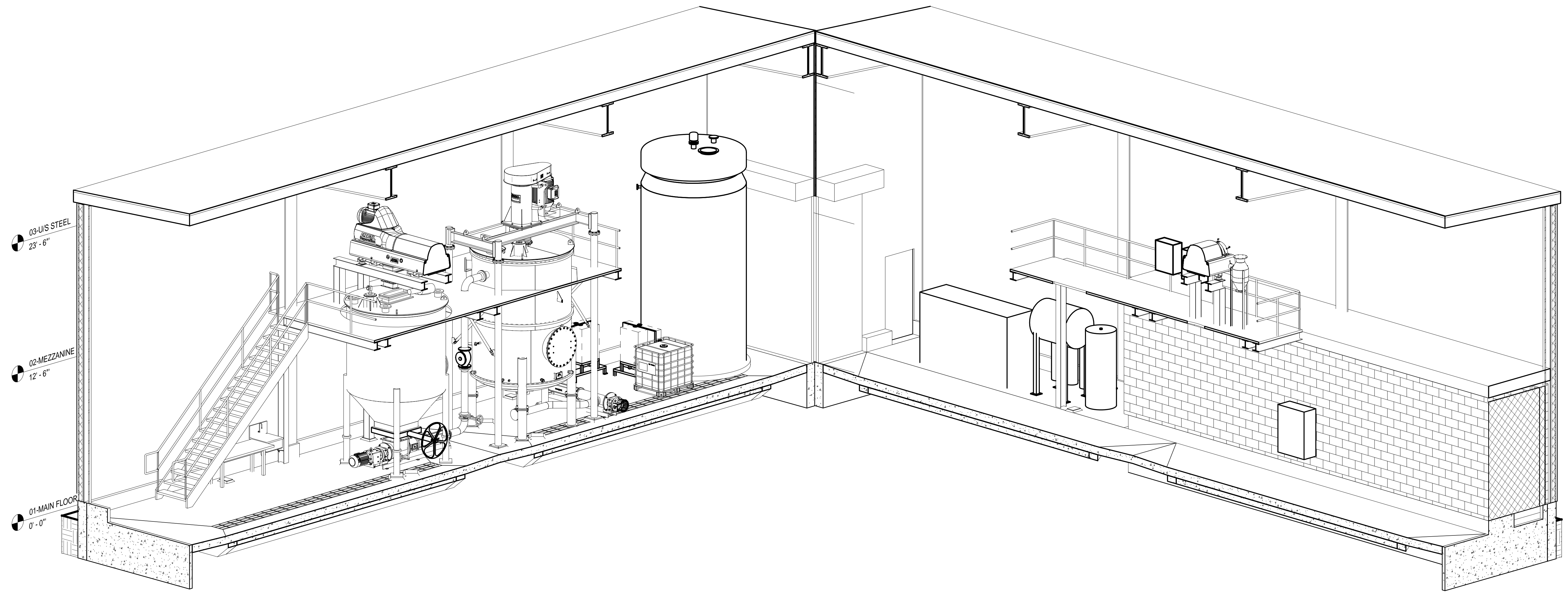

CONCEPTUAL

Automated Engineering Technologies Ltd.
 91A Duke Street, Guelph, Ontario N1E 5L1 (519)821-8644
 397 Romeo Street S., Stratford, ON, N5A 4V1 (519)273-9318 WEB: www.autoengtech.on.ca

No.	REVISION	DATE

APPROVED BY:

LYSTEK
 LY10 ARRANGEMENT
 ISOMETRIC VIEWS

Lystek International
 125 McGovern Drive, Unit #1
 Cambridge, Ont., Can., N3H 4R7
 Phone: 1-888-501-6508
 Fax: 1-888-501-7429
 Web: www.lystek.com

DESIGNED BY: T.P.	REVIEWED BY: M.B.	DRAWN BY: C.F.	DATE: 08/14/2020
SCALE:	PROJECT No. -	DRAWING No. M104	

Appendix F

EPIC Digestion/Co-Generation Demonstration Project

The Issue

Food and other organic material represents more than two-thirds of all landfilled waste annually in California (alone). An estimated six million tons of this is food waste. As it degrades in landfills, all of this material produces methane, a powerful greenhouse gas (GHG). In response to this growing problem, the State of California passed legislation to increase organics recycling by 50% over 2014 levels by 2020, creating an opportunity for innovative solutions with better uses for this organic waste to ease the burden on landfills and reduce GHG's.

The Project

Seeing an opportunity to contribute to the resolution of several challenges at once, Lystek International facilitated a partnership between the Goleta Sanitary District and the University of California, Santa Barbara with assistance from the California Energy Commission's Electric Program Investment Charge (EPIC) program.

The Lystek-Goleta Digestion & Co-Generation project will demonstrate that it is possible and economically viable to divert waste from landfills, make better use of these organic materials and create valuable products – including green energy.



The Partners

The partners have collaborated on an innovative project to process biosolids from the Sanitary District and food waste from UCSB, with the intention of performing additional, pilot testing with other organic materials. This initiative will also demonstrate how proven technologies can be leveraged to optimize the performance of existing anaerobic digesters at wastewater treatment plants as an alternative to landfilling.

The Benefits



Economy
 A high-value end-product at low cost. The demonstration project will show that organic waste can be reliably and cost-effectively converted into a renewable fuel and a high-nutrient biofertilizer. Projects like this help to reduce the cost of climate change mitigation and support local economic development through new jobs.



Environment
 Healthier people, healthier landfills. Diversion of organic material saves space in landfills while reducing greenhouse gas emissions. Properly managed organics processing is also a healthy and sustainable solution to public health and environmental risks posed by landfilling.

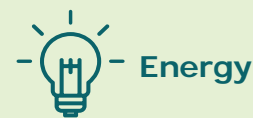

Energy
 Biogas generated can be converted into green energy. Full-scale projects leveraging proven technologies that result in successful demonstrations can help reduce our dependency on fossil fuels and support alternative approaches to recover resources and produce sustainable energy.



Proven Technologies – Working in Unison

This demonstration project will show how, when combined into a single process train, proven technologies can work together to:

- Improve organic material processing – divert waste from landfill
- Optimize digester performance to reduce waste volumes and increase biogas generation for conversion to green energy
- Produce a Class A quality biofertilizer product

Step 1: Organic waste depackaging

The **Smicon SMIMO30** unit is a proven European technology for pre-processing source-separated organics into a high-quality feedstock for anaerobic digestion. It depackages and separates packaged food waste with 99% efficiency, preparing the organic food waste for digestion.



Step 2: Digestion

The small, agitated feed tank in this step is custom designed by Lystek. The digestion process also includes two 8m³ **anaerobic digesters**, and one digestate holding tank. The depackaged organic material is pumped to the digester feed tank, and the slowly fed to the anaerobic digesters. In the anaerobic digesters, biogas is produced and collected for conversion to energy. Digestate flows out of the digesters into the holding tank, where it is either discharged to the Goleta Sanitary District or held for further processing.



Refeeding of the Lystek-processed material into anaerobic digesters results in higher volatile solids breakdown, higher gas yields, and reduced biosolids volumes.

Step 3: Lystek Thermal Hydrolysis Process

The patented and proven **Lystek THP[®]** system leverages a combination of heat, alkali, and high shear mixing to achieve effective lysis (breakdown) of the biological material in biosolids and organic materials. The process hydrolyzes macromolecules into smaller molecules that are also amenable for further utilization as a carbon source and biodegradation in any biological media, such as soil, digesters or biological nutrient removal (BNR) systems.



This demonstration project will show how increased biogas generated during the digestion process can be converted into green energy. It also showcases how this unique technology can be utilized to stabilize the organic fraction and create a product that qualifies as a USEPA Class A quality biofertilizer product.

CONTACT

Recipient: Lystek International Ltd.
James Dunbar, General Manager
Phone: (707) 419-0084
Email: jdunbar@lystek.com

GRANT INFORMATION

Grant Amount: \$1,589,163
Co-funded Amount: \$1,500,000
Project Location: Goleta Sanitary District,
1 Moffett Pl, CA 93117, USA



Appendix G

Technical Specifications Sheet



Lystek THP[®] Technical Specifications

About the Technology

Lystek THP[®], a low-temperature Thermal-Chemical Hydrolysis Process, is a sustainable solution to biosolids and organics management with full-cycle resource recovery.

Lystek THP transforms raw or digested residuals into a Class A quality biosolids fertilizer and multi-use hydrolyzed product. This technology provides operational flexibility with multiple product uses, including LysteGro[®] Class A biosolids fertilizer, LysteMize[®] digestion enhancement process, and LysteCarb[®] alternative carbon source.

Operating inputs are low pressure steam, high speed shearing, and alkali, all applied simultaneously in an enclosed Reactor.

One System. Multiple Benefits:

Lystek THP has a small footprint, is cost effective, efficient, and reliable.

Modular design makes it scalable and easy to deploy (or retrofit). The system is fully automated and simple to operate and maintain.

Additional advantages include:

- Produces a marketable, high-solids liquid Class A quality fertilizer
- Optimizes anaerobic digestion; increasing biogas production for green energy while decreasing residual volumes through improved volatile solids reduction (VSR)
- Produces a safe, cost-effective alternative source of carbon for biological nutrient removal (BNR) systems
- Significantly reduces liquid biosolids volumes
- Augment to existing plants - does not disrupt existing processes
- Autonomous and efficient operations and easy to maintain
- Comprehensive, worry-free LysteGro product management services



Lystek THP[®] Reactor

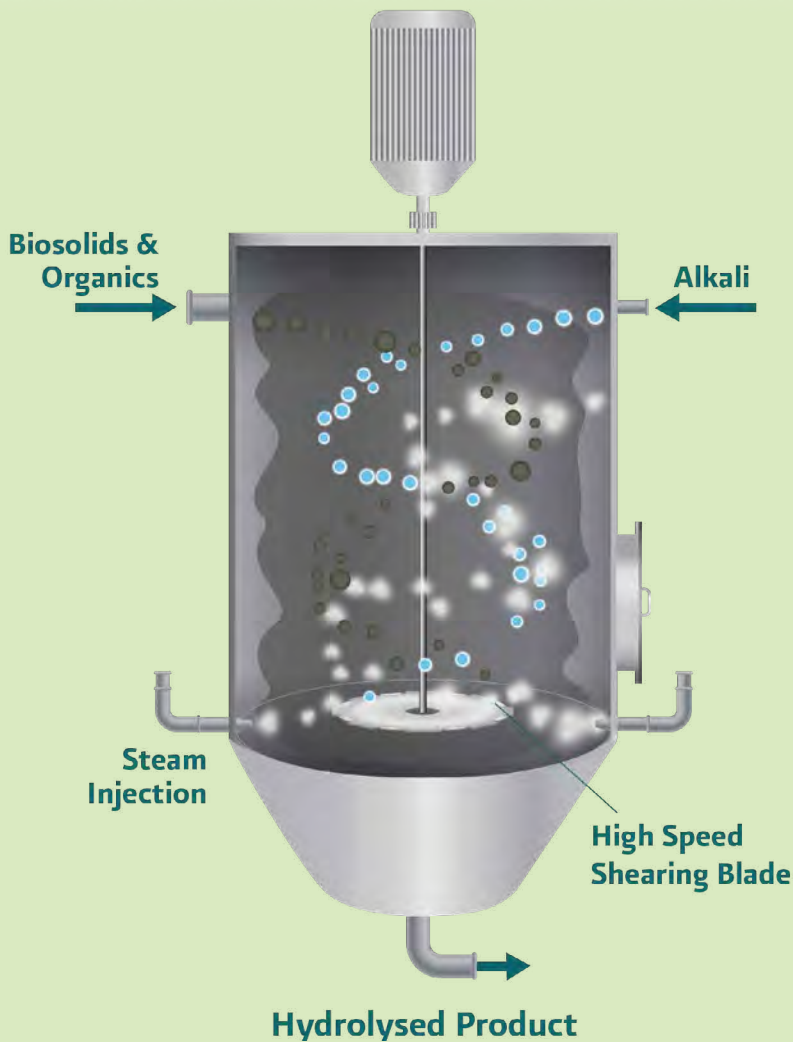

- LysteGro[®] - Class A Biofertilizer
- LysteMize[®] - Digestion Enhancement
- LysteCarb[®] - Alternative Carbon Source

Moduleⁱ Sizing

Module size	LY3	LY6	LY10
Processing rate (dry tons per hour)	0.3	0.6	1.0
Nominal processing footprint ⁱⁱ (ft ²)	800	1,250	1,600

Key Operating Parametersⁱⁱⁱ

Electrical consumption	60 kWh per dry ton
Heat requirement ^{iv}	1,100,000 BTU per dry ton
50% liquid alkali solution ^v	120 - 200 lb per dry ton
Operating temperature	167°F
Solids content - processed product	13 - 16%
Viscosity - processed product	5,000 - 10,000 cP

Valuable End Products and Processes

LysteGro [®] biofertilizer	Pathogen free, nutrient-rich, Class A quality fertilizer
LysteMize [®] digestion enhancement	Increase biogas production and volatile solids reduction
LysteCarb [®] alternative carbon source	Eliminate use of costly chemicals (i.e. methanol or glycerol) used for BNR

- ⁱ Module includes the THP Reactor and associated process equipment.
- ⁱⁱ Minimum space required for processing equipment only (Module, alkali storage, boiler). Product storage and ancillary system requirements will vary by site conditions.
- ⁱⁱⁱ Operating parameters are estimates only and will vary according to site conditions, feed stock characteristics, and intended use of hydrolysed product.
- ^{iv} Dependent upon biosolids feed temperature into the Reactor. Heat requirements estimated based upon an average feed temperature of 60°F.
- ^v Typically potassium hydroxide (KOH).

T. 226.444.0186
 TF. 888.501.6508
 E. info@lystek.com
lystek.com

Appendix H

Advantages of LysteGro



Advantages of LysteGro

Class A Quality, High Solids Liquid Biosolids Fertilizer

The Lystek Thermal Hydrolysis Process (**Lystek THP®**) technology produces a concentrated high solids liquid product, **LysteGro®**, that is considered a Class A biosolids in the US and a registered fertilizer with the Canadian Food Inspection Agency (CFIA) in Canada and with the California Department of Food and Agriculture (CDFA) in California. LysteGro has a solids content ranging from 13 – 16% with a viscosity below 10,000 centipoise. This means that it is fully pumpable using traditional liquid manure handling and application equipment.

There are several advantages to producing and managing a Class A quality, high solids liquid biosolids fertilizer.

Simple and Cost Effective Liquid Pumping and Storage Systems

Pumping LysteGro from processing to storage and from storage to truck loading is completed with standard pumps proven within the industry. This allows for rapid, familiar and low maintenance pumping operations, and accurate quantification of the volumes. Liquid solutions offer automation that is not possible with solid loading operations which often requires manned loading equipment. Concentrated liquid storage solutions reduce site footprint compared to solid options as storage tanks can be constructed with practically unlimited vertical storage capacity unbound by the slumping properties of dewatered biosolids.





Transportation Loading and Unloading Efficiencies

Depending on the site requirements, loading of tanker trucks can be completed quickly (5 – 10 minutes at larger facilities) and accurately. Additionally, the product can be transferred to the application tank in the field in as little as 5 minutes. The result is an efficient and clean program at both the facility and field sites with minimal staffing requirements.

Odor Mitigation with Enclosed System

From the point of production to application in the field, the product is contained within enclosed Reactors, piping systems, storage, tanker trucks, and finally the soil. Lystek THP generates minimal process air compared to dry alternatives, which require the evaporation of water and the liberation of odorous compounds that must then be captured and treated. This is a significant advantage when managing odor throughout the life cycle of the process.

Efficient and Cost-Effective Land Application

Due to the loading methods at the facility and in the field, LysteGro application programs are highly efficient. At the field, the product is injected into the soil subsurface, requiring only one pass over the field with the application equipment. This translates to less equipment, less staffing, and less time spent on fields as well as minimizes compaction risk and facilitates application into living crops.

Application Accuracy and Nutrient Use Efficiency

The application rate is controlled with flow meters to ensure it is placed evenly and accurately throughout the field. This provides confidence that the customer can rely on the material as a synthetic fertilizer replacement. This also creates opportunities for farmers to utilize their GPS technology to place the seed close (within 2" for example) to the band of LysteGro to optimize carbon and nutrient use efficiency. The sub-surface injection of the product minimizes nitrogen loss, maximizing the effective nutrient value of the product.

Environmental Protection

LysteGro is sub-surface injected, which increases soil contact and removes the risk of run-off. Additionally, because the material is concentrated there is a dramatic reduction in the overall water volume applied per acre versus traditional liquid programs. As a result, application above the hydraulic loading rate of the soil is not a concern with this product.

Improved Optics (Out of Sight, Out of Mind)

Injection of the product minimizes soil disturbance and the outcome is a professional job with little product on the soil surface, avoiding public nuisance and concern.

Value Proposition for the Farmer

The value proposition to the farmer is to provide a consistent quality product they can rely on to improve yields and reduce input costs. LysteGro is enhanced with potassium during the treatment process, adding further benefit to the farmer. The Lystek approach to fertilizer management is preferred by farmers compared with historical application methods, as it only requires one pass to inject and incorporate the product. Additionally, it is compatible with minimum till systems, which are rapidly growing in popularity in agricultural systems throughout North America.



T. 226.444.0186
TF. 888.501.6508
E. info@lystek.com
lystek.com



Retrofit Creates Sustainable Biosolids Management Solution

Fairfield-Suisun Sewer District, California

Lystek
Nothing wasted.
Everything to gain.



Fairfield-Suisun Sewer District enters into a unique Public-Private Partnership (P3) with Lystek to bring first, comprehensive biosolids management solution to the San Francisco Bay Area.

ABOUT

Located about 40 miles north-east of San Francisco, the Fairfield-Suisun Sewer District (FSSD) services over 135,000 people and operates 70 miles of sewer, with 13 pumping stations within 48 square miles in central Solano County.

www.fssd.com

CHALLENGES

- High and rising costs for biosolids management; diversion from landfill required
- Regulatory pressures to move towards higher treatment and beneficial use
- Under-utilized assets and spacious site
- Lack of coordinated biosolids management solution for the Bay Area

SOLUTION

The Fairfield-Suisun Sewer District entered into a 20 year (+10) public-private partnership (P3) agreement with Lystek International Ltd. to develop a regional Organic Material Recovery Center (OMRC), implementing Lystek THP under a design-build-own-operate model, providing these benefits:

- Long term sustainable biosolids management solution with extended program security
- Production of a high-quality Class A biosolids product, registered as a bulk fertilizer with the California Department of Food and Agriculture (CDFA)
- Generate revenue and local jobs; establish a regional solution for other Bay Area utilities

RESULT

- Currently providing biosolids management solutions to more than 10 Bay Area utilities
- More than **180,000 tons** (as of 2021) of biosolids converted into fertilizer and applied to local farms
- Increased biogas generation through the LysteMize process



KEY METRICS

WWTP Rating (FSSD): 5,000 m³ / day (23.7 MGD)

Population Served: 135,000

Lystek OMRC Annual Capacity: 150,000 tons

Lystek THP Module Size: 2 x **LY10**

Lystek THP Processing Footprint: 2,500 sq ft.

Feedstock: Municipal biosolids (anaerobically digested, aerobically digested, undigested), anaerobically digested organic waste products, organic-based liquid materials and processed food-grade wastes

The FSSD oversees wastewater treatment and sanitary sewers in northern California's Solano County. Prior to engaging with Lystek, the District had been sending their biosolids to landfill for use as daily cover for decades. In the early 2010s, regulatory changes began to address organic materials in landfills, and it was clear that the State would be requiring biosolids to be diverted from landfills to beneficial use. In addition, the San Francisco Bay Area expressed the need to develop regional solutions for biosolids management.

FSSD has had a long history of looking for innovative solutions for its wastewater treatment program. In 2015, the District and Lystek International Ltd. developed a public-private partnership (P3) project on-site at the FSSD wastewater treatment plant (WWTP). The partnership agreement allowed the development of the Fairfield Organic Material Recovery Center (OMRC) as a regional biosolids and organics management facility, owned and operated by Lystek, leveraging under-utilized infrastructure and assets at the FSSD plant. This facility became operational in 2016, for a duration of 20 years, with a 10-year optional extension.

The OMRC accepts organic residuals year round and, stores the fertilizer end product onsite during inclement weather periods. This fertilizer (trademarked as LysteGro) is land applied throughout the year, as field conditions allow. The material is classified as a Class A biosolids by USEPA (Part 503 standards), and has received a bulk fertilizer registration by the California Department of Food and Agriculture (CDFA). This dual-designation material has allowed LysteGro to be widely used and accepted by area farmers and ranchers as an alternative to chemical and synthetic fertilizers. The use of Class A LysteGro is now accepted in multiple counties which have historically been restrictive to traditional Class B biosolids and land application practices.

The other major opportunity of the FSSD-Lystek partnership involves enhanced digestion and biogas generation. FSSD operates anaerobic digesters to treat wastewater solids and utilize the biogas for onsite co-generation (electricity plus heat for the digesters). This practice reduces the overall plant energy dependence on fossil-fuels sources. Through the LysteMize process, a portion of the Lystek THP treated biosolids can be re-fed to anaerobic digesters to increase volatile solids destruction and boost biogas yields. The LysteMize process was demonstrated at FSSD in 2019-2020, refeeding processed biosolids from FSSD and third party generators to the digesters. Due to new California legislation related to organics diversion from landfills, generators of undigested biosolids who send their material to the OMRC are able to obtain diversion and recycling credits for the volumes processed with the use of the Lystek technology and enhanced digestion.

This successful P3 partnership between FSSD and Lystek has offered Bay Area agencies a reliable, sustainable and cost-controlled biosolids management solution. Generators now have a convenient management facility which produces and manages a Class A biosolids fertilizer, and is capable of reducing GHG emissions through additional biogas recovery in the FSSD digesters. The successful LysteGro management program has sold and applied more than 250,000 tons (as of 2021) of CDFA registered fertilizer, and is in demand from area farmers and ranchers.



About Lystek

Lystek is a leading provider of Thermal Hydrolysis solutions for the sustainable management of biosolids and organics. The multi-use, award-winning Lystek system reduces costs, volumes and GHG's by converting municipal and industrial wastewater treatment facilities into resource recovery centers. The technology transforms organic waste streams into value-added products and services, such as the patented LysteMize® process for optimizing digester performance, reducing volumes and increasing biogas production; LysteGro®, a high-value, nutrient-rich fertilizer and LysteCarb®, an alternative source of carbon for BNR systems.

Bioforcetech Biosolids to Energy and Biochar

Code: BFT-Q-22-699

Date : 03/30/2022

Project	Biosolids to Energy and Biochar Facility
Input	6,175 wet tons/year of biosolids, at 20% solids content
Output	~470 tons/year of OurCarbon™ biochar

Client info:

Name	Beverli Marshall
Company	Valley Sanitary District
Email	bmarshall@valley-sanitary.org
Phone	(760) 238-5400
Client/Project	Valley Sanitary District WWTP

Bioforcetech contacts:

Name	Valentino Villa, COO
Company address	938 Linden Ave South San Francisco, CA 94080
Phone	+1 (650)906-0193
Email	info@bioforcetech.com
Website	http://bioforcetech.com

Local Representative Contacts:

Company	MISCOWater
Direct Contact	Roger Antonie
Phone	949.300.1354
Email	rantonie@miscowater.com
Website	miscowater.com



Document index:

- 1) COVER LETTER
- 2) ABOUT BIOFORCETECH
- 3) TECHNOLOGY OVERVIEW
- 4) BIODRYER
- 5) PYROLYSIS
- 6) BIOCHAR
- 7) IMPLEMENTATION CONSIDERATIONS
- 8) PFAS/PFOA REMOVAL
- 9) PLANT DATA
- 10) BUDGETARY QUOTE
- 11) PLANT LAYOUT
- 12) REFERENCE LIST

COVER LETTER

Dear Beverli,

Bioforcetech Corporation would like to thank you for the opportunity to serve as your biosolids solution and service provider.

Bioforcetech is in the business of providing biosolids solutions using two efficient and high value processes, the Biodryer and the "P series" Pyrolysis Units. While the equipment can be used independently, the BioDryer and Pyrolysis units are most effective when configured together as an integrated system.

BFT-BioDryer

The Bioforcetech BioDryer is a unique technology that is designed to dry biosolids in order to produce a nutrient rich Class A organic material. The resulting product can be recycled and applied as a fertilizer or soil amendment.

The BFT-BioDryer can save up to 70% in energy costs compared to a conventional belt or paddle dryer since it uses the metabolic energy of bacteria that naturally occur in biosolids, instead of costly fossil fuels. Each BFT-BioDryer unit is able to dry 8 wet tons of biosolids at 20% TS in as quick as 48 hours. The result is Class A biosolids at 75-90% TS. The BFT-Biodryer is a modular configuration allowing units to be added to increase capacity and production of rich organic material.



BFT-Pyrolysis Units (P-THREE & P-FIVE)

“Pyrolysis” is the thermochemical decomposition of organic material through the application of heat without the addition of extra oxygen. Through pyrolysis Bioforectech is able to recuperate value from biosolids, transforming it into renewable energy and biochar. Biochar is a carbon based product that is no longer considered a biosolid. Biochar produced from the BFT-Pyrolysis has economic value and can be sold as a fertilizer or as a material that can be used to make sustainable products.

BFT’s pyrolysis system is provided in two configurations, the P-THREE and P-FIVE units. Both are self-sustained pyrolysis systems that generate enough energy to maintain the process, and additional thermal energy that can be recirculated back to the BioDryer for additional biosolids drying.

A complete Bioforcetech system helps municipal wastewater treatment facilities to meet their sustainability goals by “producing” a valuable product, rather than costly waste.

The Bioforcetech systems are compact, modular, and self-contained for easy installation and maintenance, as well as fully automated for 24/7 operation with little to no operator interaction.

We look forward to working with you and your Team on this and future projects. Feel free to contact me or our local representative for any questions.

Best regards,

Valentino Villa
Chief Operating Officer
P: 650-906-0193
E: v.villa@bioforcetech.com

ABOUT BIOFORCETECH

OUR MISSION

Bioforcetech is committed to protecting nature and human health by providing technologies that deliver a zero waste future, transforming organic waste into sustainable products.

Due to the traditional (and not cost-effective) methods for the treatment of these materials, BFT has created a new generation of machinery able to use up to 90% less energy. The BFT machinery has a limited environmental impact and is able to **obtain by-products with economic and commercial value**. BFT has developed the BioDryer and the P-Series pyrolysis reactor.



BFT is a partner of the **Prezezzi Extrusion Group** (www.prezezziextrusiongroup.com). The Group is based in Europe, and operates in various fields such as mechanical and renewable energy. Currently the PE group is a leader in the construction of aluminum extrusion presses, aggregate handling, industrial pyrolysis and industrial automation. In its decades of operations, the PE Group has developed a wide network of top brand partners in order to assure **the highest quality in every product**.

OUR TEAM

Founded in 2012, after years of research and pilot testing, our team has developed and deployed the first energy positive system that **UpCycles biosolids into energy and biochar**. All this was possible due to our team of talented individuals who possess tremendous skills, which range from biotech, engineering and mechanical energy, industrial automation, financial management and business administration. **With more than 30 full-scale pyrolysis installations** in Europe, and the first and only full-scale biosolids to energy system in North America, Bioforcetech assures that its team possesses the highest expertise and competence.



TECHNOLOGY OVERVIEW

From organic waste to value. The Bioforcetech system generates renewable energy, and UpCycles any organic waste into Biochar.

The BioForceTech (BFT) plant was designed and built to combine a low energy consumption drying process (mediated by bacterial activity), with a system to add value to biosolids (through a pyrolysis process), in order to obtain a plant having a positive energy balance.

BFT's ultimate objective was to build a high efficiency plant with low capital cost and limited external fossil fuel requirements.

Special features were implemented in the design to keep energy waste to a minimum. These include aeration, waste heat recovery, efficient reactor shape, and insulation methods.

Unlike most biosolids drying systems, which use high energy consumption to achieve high drying levels, the BFT drying system guarantees a high degree of drying (from 20% of dry matter to 80% of dry matter). This is accomplished by recycling the metabolic waste energy, generated by bacteria already present in biosolids, as heat.

An energy recovery system (pyrolysis reactor) makes the process sustainable and efficient. Installed downstream of the dryer, this system minimizes the use of outside energy for the complete treatment of biosolids from the wastewater treatment plant.



UPCYCLE YOUR WASTE: GENERATE BIOCHAR

“Upcycling, also known as creative reuse, is the process of transforming by-products, waste materials, useless, or unwanted products into new materials or products of better quality or for better environmental value.”

At Bioforcetech we embrace this concept and realize it with our sustainable system, converting organic waste into renewable energy and biochar.

Biochar is charcoal used as a soil amendment. Biochar is a stable solid-rich in carbon, and can endure in soil for thousands of years. Biochar thus has the potential to help mitigate climate change via carbon sequestration.



Process benefits:

- ✓ UP TO 90% VOLUME REDUCTION
- ✓ 90% LESS TRUCKS
- ✓ UP TO 100% LESS ENERGY CONSUMPTION
- ✓ FULLY AUTOMATED SYSTEM
- ✓ IMPROVED ENVIRONMENTAL AND SOCIAL IMPACT
- ✓ LOW O&M

BIODRYER



The BFT innovative process is able to dry (i.e., remove the water from) various types of biomass without the use of additives, such as fossil fuel energy, chemicals, etc. In a little over 48 hours, the BFT BioDryer dries organic materials from 20% solid content to 80% solid content and above. Use of the naturally-occurring microbial populations is the essence of our exclusive technology. By taking advantage of the microbial populations that proliferate inside high-concentration organic materials, our team has designed an extremely fast bioreactor that promotes life inside the biomass. As the bacteria grow, they emit heat that BFT uses to remove the water and tap the stored energy.

The bacteria use carbon compounds found in the biosolids to grow and reproduce. The microorganisms also need oxygen present in the air to complete these reactions. Waste heat is released during the reactions.

These metabolic reactions alone can significantly increase the temperature inside the reactor in a few hours. In a system optimized for this purpose such as the BFT BioDryer, this temperature, together with a correct air flow, are used as the means to carry and evaporate the water held by the material, thus leading to a high dry solids concentration.



Equipment:

The BioDryer is composed of an external structure that is made with painted steel to prevent rust corrosion and strength loss, and internal parts that are made of AISI 304L and AISI 304 stainless steel.

The AISI 304L is used when a welding process is needed. The stainless steel prevents fast deterioration. The reactor looks like an octagonal rotating drum and is moved by a motor reducer and linked to an aeration system. Loading and unloading gates are present on one side of the octagon.

The air system is composed of two blowers, polypropylene (PPH) pipes, and one heat exchanger. The first centrifugal fan blows the air inside the reactor and provides oxygen for the process. The second blower sucks the exhaust air and the steam formed during the process.

The PPH guarantees resistance to aggressive chemical agents and also has a good resistance to high temperatures, up to 230°F.

Batch capacity	16,000 lbs
Batch duration	48 to 72 hours
Operating Temperature	up to 160°F
Empty weight	12,000 lbs
Rotating motor	up to 18 kW
Blower power	up to 7.5 kW

BFT BIODRYER TECHNICAL SPECS - GENERIC

Volume capacity	26 m3 (812ft3)
Max material treatment capacity per batch	7,250 kg (16,000 lbs / 8 ton)
Max weight (machine + material)	23,000 kg (50,700lbs / 25.3 ton)
Material accepted	Biosolids - Manure - Organic Waste
L x W x H	12 x 4.7 x 4.6 m (40' x 15' 4-½" x 15' 2")
Operating condition outdoor	-10 to 55 °C (15 to 130 °F)
Electrical compliance	CE - NEC

BFT BIODRYER SITE REQUIREMENTS - GENERIC

Surface preparation requirements	Flat Concrete Pad
Electrical connection	Max load 88 Amps, main switch 125 Amps, 3 phase, 400-480V, 50-60Hz
Compressed air	8 bar (115 PSI)
Sewage connection	Required

BFT BIODRYER TECHNICAL PERFORMANCE - GENERIC

Type of process	Batch
Batch duration	48h to 72h
Operating temperature	Up to 70 °C (160 °F)
Yearly operating time	Up to 8,500 Hours
Max yearly material inlet per machine	Up to 1,180 metric ton/y (1,300 ton/y)
Max yearly material outlet per machine	Up to 296 metric ton/y (326 ton/y)
Min material solid content inlet	17% SC
Material solid content outlet	From 70 to 90% SC
Material output category (biosolids)	Class A / Exceptional Quality
Emission	Compliance with California Limits
Lifespan	Up to 30 years





P-Series TECHNOLOGY OVERVIEW

Pyrolysis is the thermochemical decomposition of organic material through the application of heat without the addition of extra oxygen. Through this process, which takes place at temperatures between 660 and 1,650 degrees F, two CO-products are obtained: syngas and char. Our P-Series Pyrolysis machines utilize this principle to produce renewable energy from any organic waste.

SELF-SUSTAINED PYROLYSIS

Once the pyrolysis process operating temperature is reached, the exhaust gasses from the combustion chamber are passed through the annular space between the central tube and the outer casing of the pyro-reactor, ensuring the temperatures required to perpetuate the pyrolysis process. The 24/7 process becomes self-sustained.

SUSTAINABLE BIOCHAR PRODUCTION

The only by-product of our pyrolysis system is biochar. Biochar is a high carbon material used as a soil amendment. Biochar is a stable solid, rich in carbon, and can endure in soil for thousands of years. Biochar thus has the potential to help mitigate climate change via carbon sequestration. In addition, as a soil amendment biochar can increase soil fertility, agricultural productivity, and water retention, and drastically reduce nutrient run-off.

ONE MACHINE. MULTIPLE FEEDSTOCK:

The P-Series pyrolysis machines were designed for biosolids treatment, but these systems are also able to treat a wide range of materials or mix. The BFT pyrolysis can process biosolids, manure, green waste, green waste/biosolids mix, food waste and most organic waste.

BURNING WITHOUT FLAME - ENVIRONMENT BENEFITS

The BFT Pyrolysis machine has been designed to achieve the maximum production of gaseous material. The gas is immediately burnt in a special flameless reactor. Burning the produced syngas without flame allows a lower combustion temperature, resulting in lower NOx emissions. Thanks to this special technology, the BioForceTech P-FIVE Pyrolysis system has been approved by EPA as a non-incineration process. The BFT P-FIVE is the first pyrolysis process for biosolids that has been approved by EPA and that meets the emission requirements for EPA and California regulations.

EQUIPMENT:

The P-Series pyrolysis systems are pre installed inside a custom-designed shipping container that is easy to transport and ready for installation. Like the Bio-Dryer, The BFT pyrolysis system requires only a flat cement pad for installation and does not need protection from the elements. The structure contains all the required parts: pyrolysis reactors, flameless burner, char discharge conveyor, 2 heat exchangers, blowers, electrical panel and automation with safety UPS system, heat dissipation radiators, wet scrubber for SO2 removal, activated carbon filter, syngas filter (particulate abatement devices) and a chimney with sample ports for analysis.

PYROLYSIS

Pyrolysis is the thermochemical decomposition of organic material through the application of heat without oxygen. Because no oxygen is present the **material does not combust** but the chemical compounds (i.e. cellulose, hemicellulose and lignin) that make up that material **thermally decompose into combustible gasses and biochar**.

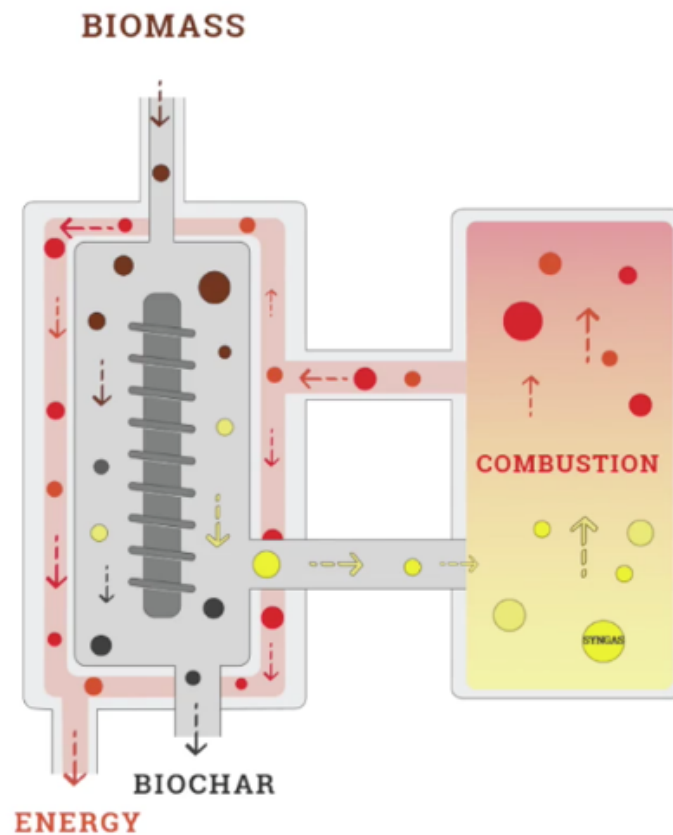
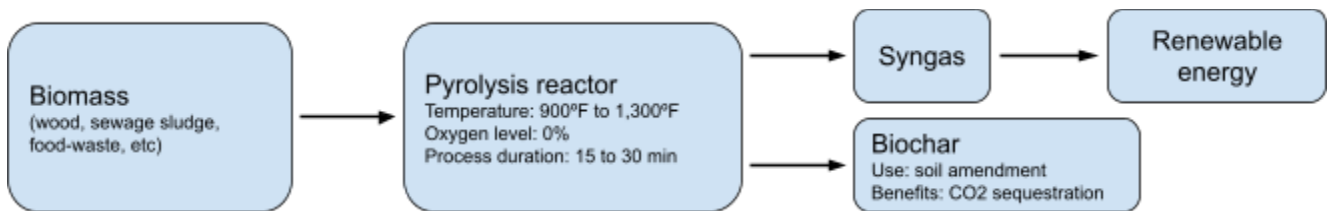

BFT P-Series PYROLYSIS UNITS

P-Series Pyrolysis machines utilize the principle of pyrolysis to produce renewable energy and biochar from any organic waste.

SELF-SUSTAINED PYROLYSIS

Once the pyrolysis process operating temperature is reached, the exhaust gasses from the combustion chamber are passed through the annular space between the central tube and the outer casing of the pyro-reactor, ensuring the temperatures required to perpetuate the pyrolysis process. The 24/7 process becomes self-sustained.

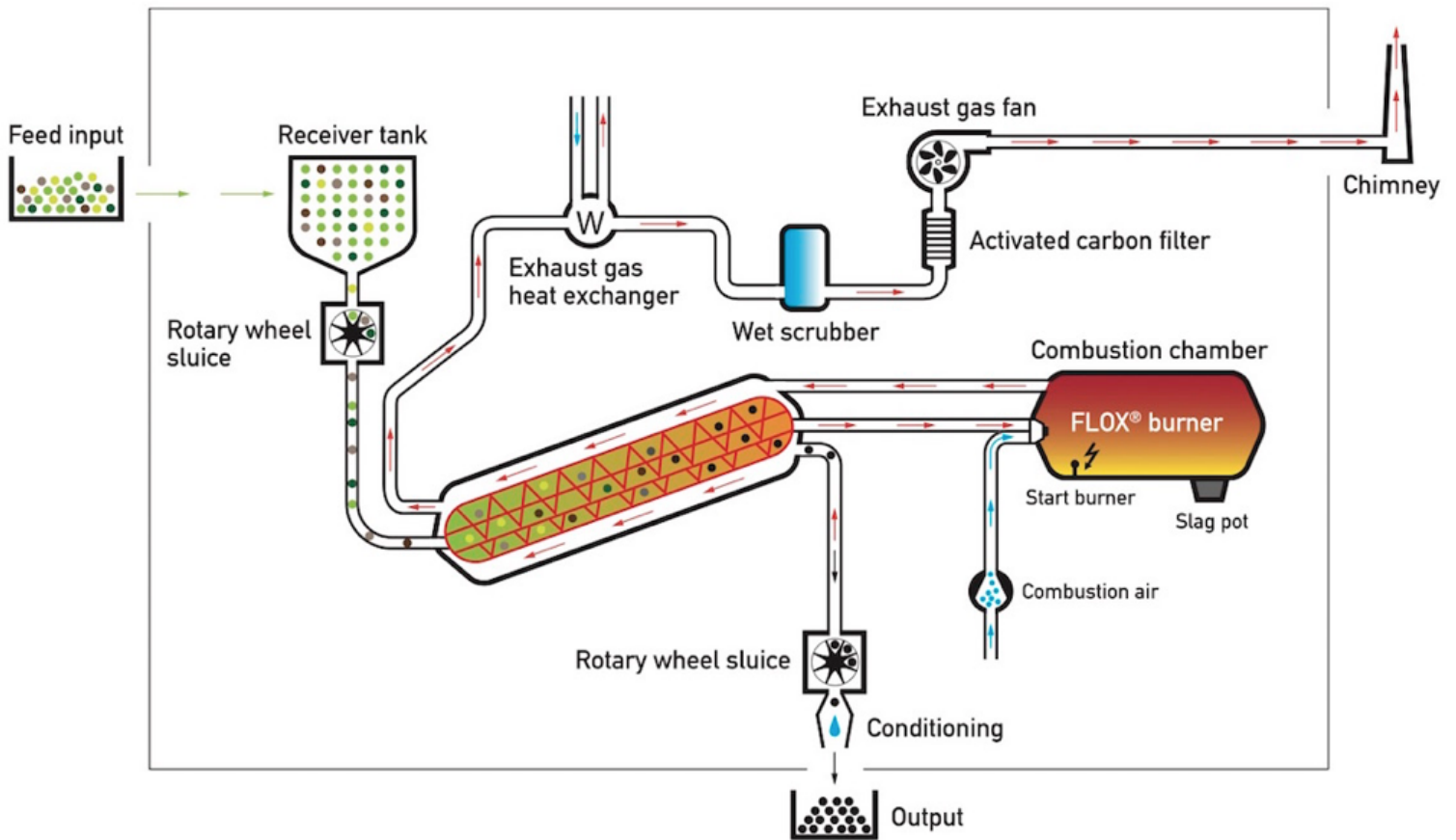

BURNING WITHOUT FLAME - ENVIRONMENT BENEFITS

The BFT Pyrolysis machine has been designed to achieve the maximum production of gaseous material. The gas is immediately burnt in a special flameless reactor. Burning the produced syngas without flame allows a lower combustion temperature, resulting in lower NOx emissions..

EQUIPMENT

The P-Series pyrolysis systems are pre installed inside a custom-designed shipping container that is easy to transport and ready for installation. The BFT pyrolysis system requires only a flat cement pad for installation and does not need protection from the elements. The structure contains all the required parts: pyrolysis reactors, flameless burner, char discharge conveyor, 2 heat exchangers, blowers, electrical panel and automation with safety UPS system, heat dissipation radiators, wet scrubber for SO2 removal, activated carbon filter, ceramic filter (particulate abatement devices) and a chimney with sample ports for analysis.

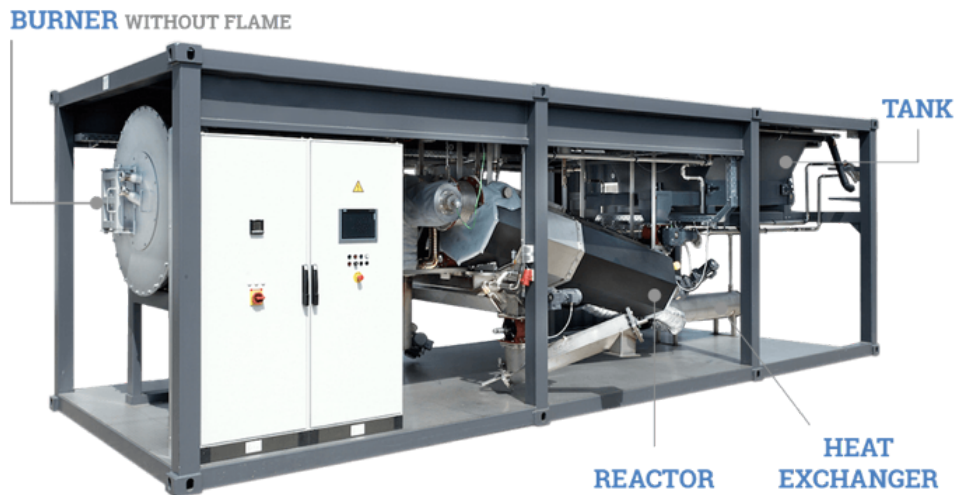

BFT P-Series TECHNICAL SPECS - GENERIC

	P-FIVE	P-THREE
Reactor weight	21,000 kg (46,300 lb / 23.1 ton)	51,000 kg (112,500 lb / 56.25 ton)
Max weight (reactor + material)	23,000 kg (50,700 lb / 25.3 ton)	53,000 kgs (117,000 lb / 58.5 ton)
Total Installed Power	40 kW (53.6 HP)	70 kW (94 HP)
L x W x H Reactor	9 x 3 x 2.8 m (29'-6" x 9'-10" x 9'-4")	13 x 3 x 5.8 m (42'-8" x 9'-10" x 19")
L x W x H Technical Container	6 x 3 x 4.9 m (19'-8" x 9'-10" x 16')	12 x 3 x 5.8 m (39'-10" x 9'-10" x 19")
Operating Condition Outdoor	-20 to 40 °C (0 to 105 °F)	-20 to 40 °C (0 to 105 °F)
Electrical Compliance	CE - NEC	CE - NEC
Material Accepted	Biomass-Biosolids-Organic Waste (not Municipal Solid Waste)	Biomass-Biosolids-Organic Waste (not Municipal Solid Waste)
Biochar Production	Yes	Yes
Energy production	Yes, Thermal	Yes, Thermal
Bio-Oil production	No	No

***The height can be increased to 30' if the material has very high dust.**

BFT P-Series TECHNICAL PERFORMANCE - GENERIC

	P-FIVE	P-THREE
Type of process	Continuous Process 24/7	Continuous Process 24/7
Yearly operating time	Up to 7,500 Hours	Up to 7,500 Hours
Operating temperature	From 350 to 720 °C (from 660 to 1,330 °F)	From 350 to 720 °C (from 660 to 1,330 °F)
Min Residence time	10 min	10 min
Max material treatment Capacity	120 kg/h @ 80% solids 265 lb/h	400 kg/h @ 80% solids 880 lb/h
Min material Treatment Capacity	50 kg/h @ 80% solids 110 lb/h	165 kgs/h @ 80% solids 365 lb/h
Max material Inlet per year	900 metric ton/y @ 80% solids (990 ton/y)	3,000 metric ton/y @ 80% solids (3,300 ton/y)
Max Biochar Outlet per year	360 metric ton/y (400 ton/y)	1,200 metric ton/y (1,325 ton/y)
Min Material Solids Content Inlet	60%-80%, depending on BTU/lb	60%-80%, depending on BTU/lb
Material Particle Size	Max 2.5 cm every direction (1 inch every direction)	Max 3.2 cm every direction (1-1/4 inch every direction)
Material Solid Content Outlet	Above 90% SC	Above 90% SC
Material Output Category (biosolids)	High Quality Biochar	High Quality Biochar
Thermal Energy produced	Up to 150 kW (512,000 BTU/hr)	Up to 600 kW (2 MMBTU/hr)
Emission	Compliance with EPA	Compliance with EPA
Lifespan	Up to 30 years	Up to 30 years

BFT P-Series SITE REQUIREMENTS - GENERIC

Surface Preparation	Flat Concrete Pad	Flat Concrete Pad
Electrical Connection	80 amps main switch, 3 phase, 400-480V, 50-60Hz	200 amps main switch, 3 phase, 400-480V, 50-60Hz
Compressed Air/Nitrogen	8 bar (115 psi)	8 bar (115 psi)
Water connection	1" pipe	2" inch pipe
Sewage Connection	2" pipe	4" pipe
Natural Gas/GPL	1" pipe, 20 inch of water +/- 5%	1" pipe, 40 inch of water +/- 5%



BIOCHAR

Biochar is a high-carbon, fine-grained residue that today is produced through modern pyrolysis processes.

In recent years, multiple university researchers have paid particular attention to biochar, for its soil remediation properties and climate benefits.

Biochar can be distinguished from charcoal, which is used mainly as a fuel. Biochar is primarily used as a soil amendment to improve soil functions and to reduce emissions from biomass that would otherwise naturally degrade to greenhouse gasses.

Biochar and the climate challenge

Fossil fuels are carbon positive; they add more carbon dioxide (CO₂) and other greenhouse gasses to the air and thus exacerbate global warming. Ordinary biomass fuels are carbon neutral; the carbon captured in the biomass by photosynthesis would have eventually returned to the atmosphere through natural processes like decomposition. Sustainable biochar systems can be carbon negative by transforming the carbon in biomass into stable carbon structures in biochar which can remain sequestered in soils for hundreds and even thousands of years. The result is a net reduction of CO₂ in the atmosphere.

Carbon in biochar can persist in soils over long time scales. Beyond the carbon sequestered in the biochar itself, biochar incorporated in soils also offers numerous other potential climate benefits.

1. **Soil Fertility:** Biochar can improve soil fertility, stimulating plant growth, which then consumes more CO₂ in a positive feedback effect.
2. **Reduced fertilizer inputs:** Biochar can reduce the need for chemical fertilizers, resulting in reduced emissions of greenhouse gasses from fertilizer manufacture.
3. **Reduced N₂O and CH₄ emissions:** Biochar can reduce emissions of nitrous oxide (N₂O) and methane (CH₄)—two potent greenhouse gasses—from agricultural soils.
4. **Enhanced soil microbial life:** Biochar can increase soil microbial life, resulting in more carbon storage in soil.
5. **Reduced emissions from feedstocks:** Converting agricultural and forestry waste into biochar can avoid CO₂ and CH₄ emissions otherwise generated by the natural decomposition or burning of the waste.

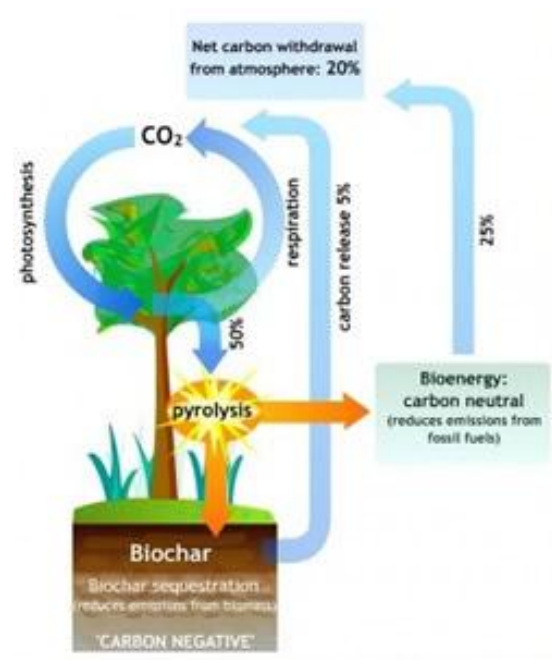

IMPLEMENTATION CONSIDERATIONS

Regulatory implications

Bioforcetech's existing biosolids plants met or exceeded all regulatory requirements. Because our plants are lower impact than any known alternative, we have not found regulations to impede adoption of our technology. Our Redwood City, California plant has met or exceeded all EPA and Bay Area Air Quality Management District (California, USA) regulations. Even though an air permitting process might be required, Bioforcetech is positive that this process will be fairly quick without complications. Our existing permit with the Bay Area Air Quality Management District has created a roadmap for effectively permitting facilities within the jurisdiction.

Aesthetics (odor, noise, visual impact, etc.)

Bioforcetech's existing biosolid plants reduce all impacts. Because our plants have a lower impact than any known alternative, we have not found aesthetic, visual, odor, noise, cultural, or other impacts to impede the adoption of our technology. Our Redwood City, California plant is so quiet and low impact that guests actually ask if the plant is on. The operation of the plant makes no more noise than the operation of your car.



Got EPA approval for a NON-Incineration thermal process



Got a permit to operate in the toughest Air district in the USA



Approving the BFT Pyrolysis technology as a "landfill diversion method"

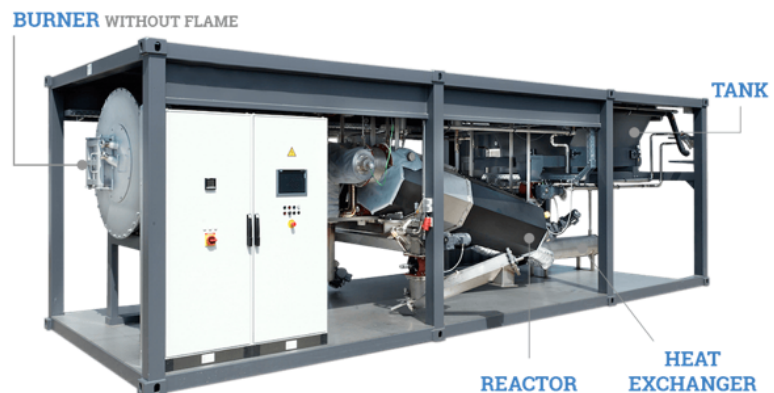

First Pyrolysis of Sewage Sludge Permitted in the USA!

PFAS/PFOA REMOVAL

In September 2019, Bioforcetech conducted an internal study to evaluate the fate of 38 PFAS and PFOAS compounds using this method. The results are published in this article for the first time showing the P-FIVE Reactor as an effective method for removing PFAS and PFOA from municipal Biosolids at an industrial scale.

<https://medium.com/nature-is-awesome-bioforcetech/eliminating-pfas-from-biosolids-is-no-longer-a-mystery-f56b94d7bfb>

Compound Name	Dry Biosolids (ng/g)	Biochar (ng/g)
PFBA	7.03	Not Detected
3:3 FTCA	ND	Not Detected
PFPeA	5.94	Not Detected
PFBS	2.3	Not Detected
4:2 FTS	ND	Not Detected
PFHxA	33.7	Not Detected
PFPeS	ND	Not Detected
HFPO-DA	ND	Not Detected
5:3 FTCA	64.5	Not Detected
PFHpA	7.45	Not Detected
ADONA	ND	Not Detected
PFHxS	ND	Not Detected
6:2 FTS	ND	Not Detected
PFOA	89.1	Not Detected
PFHpS	ND	Not Detected
7:3 FTCA	40	Not Detected
PFNA	5.3	Not Detected
PFOSA	ND	Not Detected
PFOS	26.3	Not Detected
9Cl-PF3ONS	ND	Not Detected
PFDA	11.3	Not Detected
8:2 FTS	5.68	Not Detected
PFNS	ND	Not Detected
MeFOSAA	23.5	Not Detected
EtFOSAA	19.6	Not Detected
PFUnA	3.39	Not Detected
PFDS	ND	Not Detected
11Cl-PF3OUdS	ND	Not Detected
10:2 FTS	ND	Not Detected
PFDoA	5.85	Not Detected
MeFOSA	ND	Not Detected
PFTrDA	ND	Not Detected
PFTeDA	2.44	Not Detected
EtFOSA	ND	Not Detected
PFHxDA	ND	Not Detected
PFODA	ND	Not Detected
MeFOSE	17.1	Not Detected
EtFOSE	ND	Not Detected

PLANT DATA - BioDryers + P-FOUR Pyrolysis Unit

Plant requirements:

Input material: biosolids at 20% solids content

Additional feedstock: no additional feedstock is required

Utilities required:

- Electricity (max load 88 amps, main switch 125 amps breaker each BioDryer and 180 amps main switch each P-FOUR Pyrolysis)
- Natural gas or propane (1 inch line, pressure 40 inch of H2O +- 5%)
- Potable/Recycling Water (2 inch pipe)
- Water Discharge (4 inch connection PP pipe)
- Internet (1Mb/s)

Site: The only site requirement is a flat cement pad. The entire system can be installed outside, although we recommend a carport cover for UV and weather protection. If temperatures are lower than 15°F, a heated building might be required to ensure proper operations.

Input: 6,175 wet tons/year of biosolids, at 20% solids content

Output: ~470 tons/year of OurCarbon™ biochar

Lifespan: up to 30 years

Up Running time: average of 8,000 hours/year

Estimated energy consumption:

Electricity: 60-80 kWh/wet ton

Heat (natural gas or propane): 250-500 MMBTU/year - only for pyrolysis start-up

Number of BioDryers: 6

Number of P-FOUR: 1

Pollution control: Sulfuric acid scrubber, thermal oxidizer, ceramic filter, NaOH scrubber and GAC filter



BUDGETARY QUOTE: BioDryers + P-FOUR Pyrolysis Unit

BioDryers and Ancillary Equipment

- Six (6) BFT BioDryers
- Six (6) BioDryer feeding shaftless screw conveyors
- Two (2) BioDryer distribution feeding screw conveyors
- Two (2) bottom chain conveyors for dried solids
- BioDryer catwalks for maintenance access
- BioDryer standard cleaning system for exhaust air (two (2) sulfuric acid scrubbers)
- One (1) dried biosolids storage tank
- Backup conveyance to discharge dried Class A biosolids (up to 50ft)
- Conveyance from dried biosolids storage tank to the P-FOUR unit
- One (1) backup gas water heater
- Two (2) air compressors
- Six (6) BioDryer standard electrical and control panels (non-classified environment)
- One (1) general electrical panel with proprietary controls (non-classified environment)

Pyrolysis System

- One (1) BFT P-FOUR Pyrolysis unit
- One (1) Pyrolysis exhaust gas cleaning system (NaOH scrubber, GAC filter and mist eliminator)
- One (1) Ceramic filter purged with nitrogen
- P-FOUR catwalks for maintenance access
- One (1) Biochar unloading conveyor and one (1) Biochar bagging station
- One (1) nitrogen generator
- P-FOUR standard electrical panels with proprietary controls

Engineering Services

- Support to consulting engineering firm: 0 to 100% design
- Submittals
- Permitting support to consulting engineering firm

Other Services

- Shipping of All Equipment to Client's site
- Installation inspection, start-up, commissioning and training
 - Includes Four (4) BFT personeel for up to 25 business days within three months and two (2) BFT German partner personeel (Pyreg GmbH) for the pyrolysis commissioning.
 - Includes travel, lodging and travel expenses.

Total cost for all the above: \$7,450,000

All prices are in 2022 US\$ and subject to changes based on market conditions.

Not Included in the proposal:

- Engineering support or site visit unless stated otherwise
- Conveying system from dewatering building to the BFT plant
- Light building for weather protection
- Project Management and Permitting Support unless stated otherwise
- Construction and Site Preparation
- Emission stack(s)
- Air emission testing / stack testing / performance verification testing
- All utilities that are required for operation
- Unloading, uncrating, installation and installation supervision
- Readiness of the Equipment before requesting start-up service. Non-readiness may incur additional charges
- Compatibility of Equipment materials of construction with process environment
- Piping connections, ductwork, platforms, conveyance structures & supports, gratings and railings unless stated otherwise
- Bonding for the equipment
- Any other auxiliary equipment or service not detailed above
- Taxes, Duties and fees for containers held at the designated port in excess of 5 days
- Sales taxes
- Everything not included in the list above

*Estimated annual O&M cost (BioDryers + Pyrolysis): **\$123,225***

O&M cost breakdown:

- o Utilities: \$48,225
 - (electricity @ \$0.1/kWh): \$43,225
 - (natural gas @\$1/therm): \$5,000
- o Spare parts and components replacement: \$75,000
- o Maintenance: ~700 hours/year
- o Operation (24/7 - fully automated)

Value Back Program

Bioforcetech offers an off-take agreement for the biochar our machines produce, guaranteeing a \$0 per tonne disposal fee for the Utility and a 10% share of net sale profits of the material.

Biochar sales price: \$400/ton

Cost of sale: \$100/ton

Client profit share (10%): \$30/ton

Biochar produced: ~470 tons/year

*Biochar estimated revenues for Valley Sanitary District: **\$14,100***

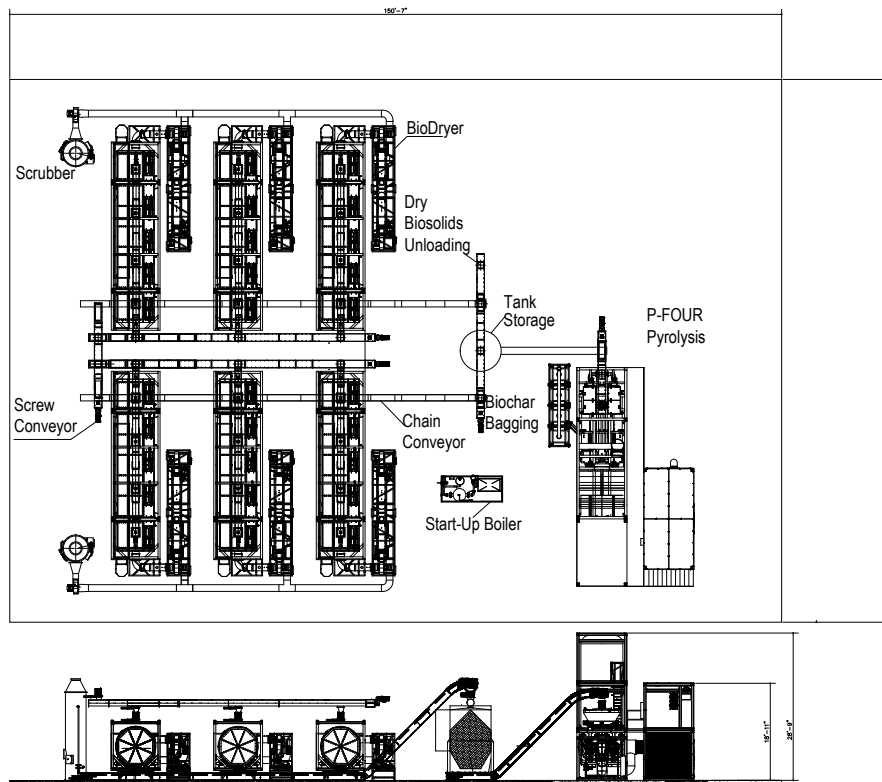

Confidential

Rev	DATE	CHG	BY	APP	DESCRIPTION
001	01/09/2022	E			
002		C			
003		D			
004		E			
005		F			

Project: BFT-Q-22-009		Revision: Layout	
Size	Sheet	111	

Not showing and shall be subject to contract documents or conditions of the contract or as otherwise indicated in notices or field instructions, notes and conditions of contract award.

REFERENCE LIST

More available upon request

United States

1) Silicon Valley Clean Water; Redwood City CA

Installation date: June 2017

Full Scale: 3 BioDryers and 1 P-FIVE Pyrolysis

Feedstock: Anaerobically Digested Biosolids

2) Yakama Legends Casino

Installation date: January 2019

1 BioDryer for Biosolids

Feedstock: Undigested Sludge

Italy

1) Brianzacque SpA

4 BioDryers and 1 P-FIVE

Project phase: in commissioning

ETA for commissioning: Q2 2022

Feedstock: Undigested Sludge

2) Gruppo CAP

1 BioDryer + 6 BioDryers to expand the facility + 1 lab scale pyrolysis system

Project phase: Commissioned December 2019

Feedstock: Anaerobically Digested Biosolids

3) Acegas

2 BioDryers

Project phase: commissioned

ETA for commissioning: September 2021

Feedstock: Anaerobically Digested Biosolids

Europe (Pyreg Partner) - Biosolids

1) Entsorgungsverband Saar (EVS)

SITE Homburg

COUNTRY Germany

NUMBER OF P-FIVE UNITS 1

IN COMMISSION SINCE 2016

PROCESS

- Recycling of sewage sludge
- Production of phosphorus fertilizer
- Using surplus excess energy

INPUT

- Dried sewage sludge

2) WASTE WATER TREATMENT LINZ-UNKEL

SITE Unkel

COUNTRY Germany

NUMBER OF P-FIVE UNITS 1

IN COMMISSION SINCE 2015

PROCESS

- Recycling sewage sludge
- Production of phosphorus fertilizer
- Using surplus excess energy

INPUT

- Dried sewage sludge

3) Skanefro

SITE Hammenhöög

COUNTRY Sweden

NUMBER OF P-FIVE UNITS 1

IN COMMISSION SINCE 2019

PROCESS

- Recycling sewage sludge
- Production of phosphorus fertilizer
- Using surplus excess energy

INPUT

- Dried sewage sludge

Other Biomasses

1) STOCKHOLM VATTEN

SITE Stockholm

COUNTRY Schweden

NUMBER OF P-FIVE UNITS 1

IN COMMISSION SINCE 2017

PROCESS

- Recycling of biomass
- Production of biochar
- Using surplus excess energy

INPUT

- Green waste

2) A. H. MEYER (ROESS NATURE GROUP)

SITE Tianjin

COUNTRY China

NUMBER OF P-FIVE UNITS 1

IN COMMISSION SINCE 2016

PROCESS

- Recycling of biomass
- Production of biochar
- Using surplus excess energy

INPUT

- Straw
- Coconut fiber

3) FINZELBERG GMBH & CO. KG

SITE Andernach

COUNTRY Germany

NUMBER OF P-FIVE UNITS 1

IN COMMISSION SINCE 2015

PROCESS

- Recycling of biomass
- Production of biochar
- Using surplus excess energy

INPUT

- Production residues

4) SITE Riedlingsdorf

COUNTRY Austria

NUMBER OF P-FIVE UNITS 1

IN COMMISSION SINCE 2011

PROCESS

- Recycling of biomass
- Production of biochar
- Using surplus excess energy

INPUT

- Green waste
- Grain husks
- Paper fiber sludge

5) FETZER ROHSTOFFE + RECYCLING GMBH

SITE Eislingen

COUNTRY Germany

NUMBER OF P-FIVE UNITS 3

IN COMMISSION SINCE 2013, 2017

PROCESS

- Recycling of biomass
- Production of biochar
- Using surplus excess energy

INPUT

- Forestry & agriculture residues
- Paper fiber sludge

6) AWASTE MANAGEMENT SOCIETY LTD. OF NECKAR-ODENWALD-DISTRICT

SITE Buchen

COUNTRY Germany

NUMBER OF P-FIVE UNITS 1

IN COMMISSION SINCE 2016

PROCESS

- Recycling of biomass
- Production of biochar
- Using surplus excess energy

INPUT

- Green waste
- Various biomass

7) WASTE MANAGEMENT & CITY CLEAN FREIBURG

SITE Freiburg

COUNTRY Germany

NUMBER OF P-FIVE UNITS 1

IN COMMISSION SINCE 2017

PROCESS

- Recycling of biomass
- Production of biochar
- Using surplus excess energy

INPUT

- Green waste
- Various biomass

8) GEIGER PFLANZENKOHLE UND ENERGIE GMBH

SITE Parsdorf

COUNTRY Germany

NUMBER OF P-FIVE UNITS 1

IN COMMISSION SINCE 2014

PROCESS

- Recycling of biomass
- Production of biochar
- Using surplus excess energy

INPUT

- Green waste
- Forestry & agriculture residues

9) VERORA GMBH

SITE Edlibach

COUNTRY Switzerland

NUMBER OF P-FIVE UNITS 1

IN COMMISSION SINCE 2012

PROCESS

- Recycling of biomass
- Production of biochar
- Using surplus excess energy

INPUT

- Green waste
- Screenings
- Wood chips

10) GREENPOCH (SA)

SITE Wagnelée

COUNTRY Belgium

NUMBER OF P-FIVE UNITS 1

IN COMMISSION SINCE 2016

PROCESS

- Recycling of biomass
- Production of biochar
- Using surplus excess energy

INPUT

- Green waste

11) CARBONIS GMBH & CO. KG

SITE Garrel

COUNTRY Germany

NUMBER OF P-FIVE UNITS 2

IN COMMISSION SINCE 2016, 2017

PROCESS

- Recycling of biomass
- Production of feeding char
- Using surplus excess energy

INPUT

- **wood chips**

12) WEHRMANN'S LÄRCHENHOF

SITE Wurster North Sea Coast

COUNTRY Germany

NUMBER OF P-FIVE UNITS 1

IN COMMISSION SINCE 2017

PROCESS

- Recycling of biomass
- Production of biochar
- Using surplus excess energy

INPUT

- Green waste
- Various wooden material

13) Ebersbach, Germany

Install date: 2013/2016/2017

Full Scale P-FIVE Pyrolysis Units

Contact information: christoph.zimmermann@du-willkommen.de

14) Dorth, Germany

Install date: 2014/2017

Full Scale P-FIVE Pyrolysis Units

Contact information: s.schmidt@novocarbo.de

This proposal is not a guaranteed quote or scope of work--rather it is an estimate based on the best information available.

The contents of this document and any attachments are intended solely for the addressee(s) and may contain confidential and/or privileged information and may be legally protected from disclosure. If you are not the intended recipient of this document or their agent, or if this document has been addressed to you in error, please immediately alert the sender and then delete this document and any attachments. If you are not the intended recipient, you are hereby notified that any use, dissemination, copying, or storage of this message or its attachments is strictly prohibited.

2021 REFERENCES

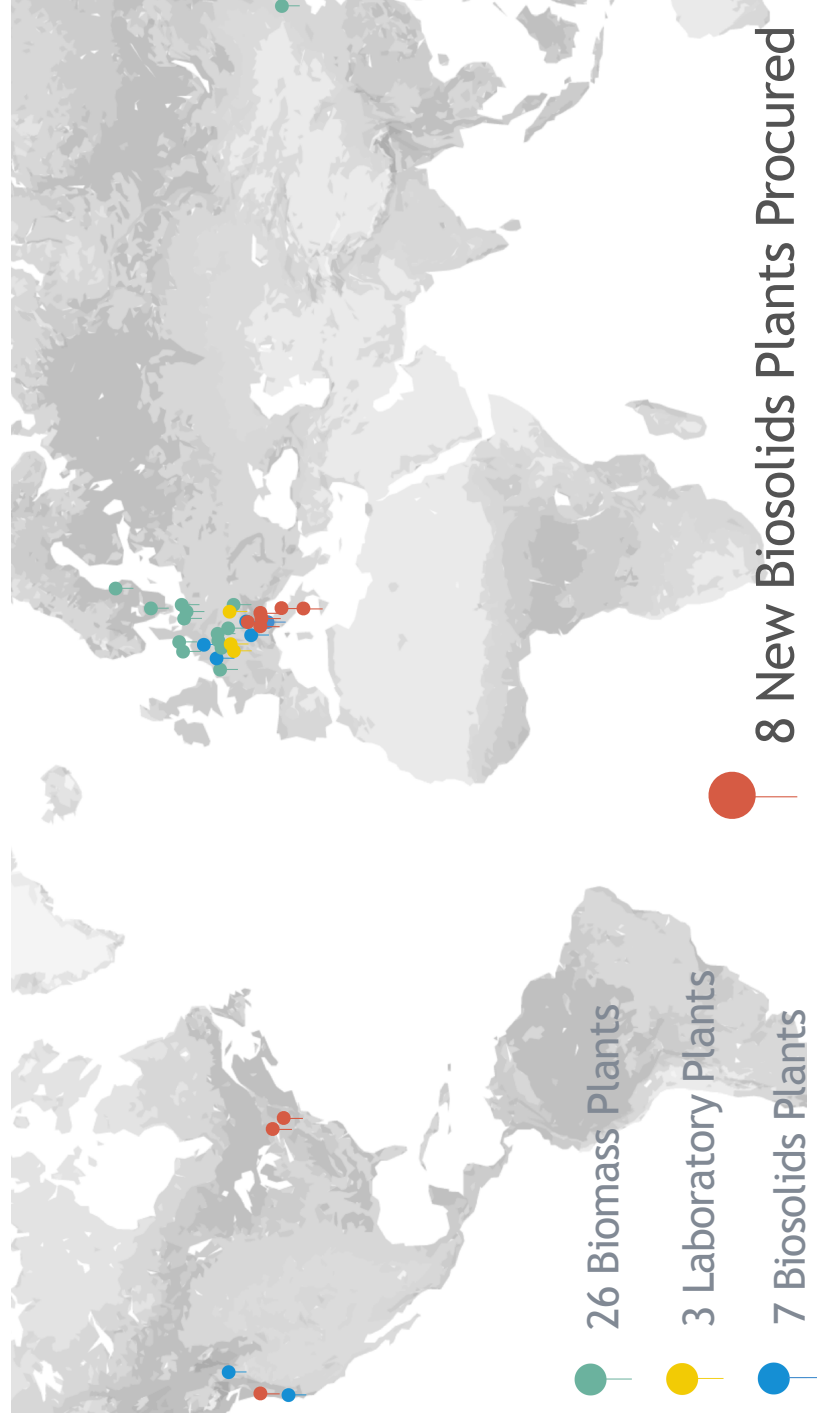

Article

A Proposal for Recycling the World's Unused Stockpiles of Treated Wastewater Sludge (Biosolids) in Fired-Clay Bricks

Abbas Mohajerani * , Aruna Ukwatta, Tristan Jeffrey-Bailey, Michael Swaney, Mohtashim Ahmed, Glen Rodwell, Simon Bartolo, Nicky Eshtiaghi and Sujeeva Setunge

School of Engineering, RMIT University, 124 La Trobe Street, Melbourne, VIC 3000, Australia; aruna.ukwatta@rmit.edu.au (A.U.); t.jeffreybailey@gmail.com (T.J.-B.); s3238709@student.rmit.edu.au (M.S.); s3360265@student.rmit.edu.au (M.A.); glenaidanrodwell@gmail.com (G.R.); s3439449@student.rmit.edu.au (S.B.); Nicky.Eshtiaghi@rmit.edu.au (N.E.); Sujeeva.Setunge@rmit.edu.au (S.S.)

* Correspondence: abbas.mohajerani@rmit.edu.au; Tel.: +61-3-9925-3082

Received: 23 November 2018; Accepted: 13 December 2018; Published: 5 January 2019



Abstract: Millions of tonnes of leftover biosolids are increasingly stockpiled every year around the globe. Biosolids are a product of the wastewater sludge treatment process. Stockpiles necessitate the use of large areas of increasingly valuable land. Biosolids have many beneficial uses and are currently utilised in agricultural and land rehabilitation applications. However, it is estimated that 30% of biosolids are unused and stockpiled. A second and seemingly unrelated environmental issue is the massive excavation of virgin soil for brick production. The annual production of 1500 billion bricks globally requires over 3.13 billion cubic metres of clay soil—equivalent to over 1000 soccer fields dug 440 m deep or to a depth greater than three times the height of the Sydney Harbour Bridge. This paper investigates and proposes a practical solution for the utilisation of the world's excess biosolids in fired-clay bricks. The physical, chemical and mechanical properties of fired-clay bricks incorporating 25%, 20%, 15% and 10% biosolids have been tested. Bricks were produced from three different biosolids samples collected at Melbourne's Eastern Treatment Plant (ETP 22) and the Western Treatment Plant (WTP 10 & WTP 17–29). Compressive strength testing indicated results ranging between 35.5 MPa and 12.04 MPa for the biosolids-amended bricks. Leachate analysis was conducted on the bricks before and after firing, and the results demonstrate that between 43 and 99% of the heavy metals tested were immobilised inside the fired bricks compared to the heavy metals tested in the raw mixture. All leachate concentrations were found to be insignificant for the biosolids-incorporated bricks tested in this study. Biosolids can have significantly different chemical characteristics depending on the origin of the wastewater and the treatment procedure. Suitable leachate analysis should be undertaken on biosolids and test bricks before large-scale production is approved. Scanning Electron Microscopy (SEM) images illustrate that biosolids-amended bricks have a higher porosity than the control bricks, which corresponds to the lower thermal conductivity values recorded for biosolids-amended bricks. In addition, brick firing energy demands are estimated to decrease by up to 48.6% for bricks incorporating 25% WTP 17–29 biosolids due to the higher organic content of the mixture containing biosolids. The emissions study and comparative Life Cycle Assessment results show that the incorporation of biosolids into bricks is a positive and sustainable alternative approach with respect to all environmental impacts arising from the stockpiling of biosolids and brick manufacturing. Based on the results found in this comprehensive study, this paper proposes the inclusion of a minimum of 15% biosolids content into 15% of brick production in order to completely recycle all the approximately 5 million tonnes of annual leftover biosolids production in Australia, New Zealand, the EU, the USA and Canada. This is a practical and sustainable proposal for recycling all the leftover biosolids worldwide. Utilisation of only 15% of biosolids in brick production would reduce the carbon footprint of brick manufacturing whilst satisfying all the environmental and engineering requirements for bricks.

Keywords: fired-clay bricks; green building materials; energy saving; recycling waste materials; wastewater treatment solids; biosolids; sludge

1. Introduction

Biosolids are the product of dewatered and appropriately treated wastewater sludge, resulting from the wastewater treatment process. Untreated wastewater sludge mainly consists of water and organic material, and, prior to further treatment, comprises approximately 8% dry solids. After undergoing treatment, wastewater sludge is referred to as biosolids and can contain between 15% and 90% dry solids [1].

The European Union produces over 9 million tonnes of biosolids annually [2]. The production of biosolids is also significant in the USA, where 7.1 million tonnes are produced yearly, of which 28% is estimated to go to landfills [3,4]. Australia produces approximately 300,000 tonnes of biosolids per year, and, of this amount, 55% is recycled for use in agricultural applications, 15% is used for land rehabilitation, compost or forestry and the remaining 30% is either discarded in landfills or stockpiled [1,5,6]. The Eastern Treatment Plant (ETP) and Western Treatment Plant (WTP) (Figure 1) in Melbourne combined have over 3 million cubic metres of biosolids stockpiled. Unless suitable pathways for reuse are found, stockpiles will increase with time, as the population of Victoria is forecast to experience significant growth over the next 40 years. Developing sustainable recycling options will lead to diminishing biosolid stockpiles over time. Stockpiling biosolids can cause the emission of greenhouse gases, and may result in the loss of valuable nutrients. Therefore, strategies for recycling leftover biosolids generated from the wastewater treatment process are essential for reducing the amount of biosolids deposited into stockpiles.



Figure 1. Western Treatment Plant Stockpile.

The production of biosolids has increased significantly, and is mainly due to the increased development of municipal wastewater treatment strategies globally [7–10]. These strategies include the construction of new treatment facilities, the expansion of existing treatment plants and the introduction of legislative measures. This increase is expected to continue as populations surge and developing nations improve their wastewater treatment processes.

Recently, sustainable development methods have been targeting the reuse of construction, pavement and concrete materials [6,11–16]. The use of biosolids in civil engineering applications, however, is a relatively new and innovative approach. One such study that yielded positive results examined the use of biosolids and fine recycled glass in road embankments [17,18]. Another study [19] conducted an extensive laboratory evaluation of the geotechnical properties of biosolids and found that

when blended with an additive they can be used as an embankment fill material. Maghoolpilehrood et al. [20] had a similar finding when using cement or lime as the additive.

The extensive use of bricks in the construction industry, combined with the structural composition of bricks, offers a unique opportunity for recycling waste [21,22]. A recent review paper provided an extensive review of numerous studies that have analysed the effects of recycling varying waste materials in bricks, including sawdust, petroleum waste, recycled paper process residue and steel slag, to name only a few [23,24]. Approximately 1500 billion bricks are produced globally every year [25,26]. Australia alone produced 1.31 billion in 2013 [27]. The varying composition of clay means that bricks can tolerate high percentages of waste and remain a viable construction option [28]. Waste materials that have been incorporated in bricks include cigarette butts [25], paper processing residue [29], sludge [30–35], fly ash [36], rice husk ash [37], granulated blast furnace slag [38], polystyrene [24], sawdust [39,40], and waste glass [41]. Liew et al. [28,34] used dewatered sewage sludge to make fired-clay bricks with different waste compositions; bricks were produced with a proportion of sludge ranging from 10–40% by dry weight. The properties of these bricks were analysed and the results indicated that the sludge content used in the mixture plays an essential role in determining the quality of the brick.

This study presents an analysis of clay fired bricks incorporating 25%, 20%, 15% and 10% by weight of biosolids from Melbourne’s Eastern Treatment Plant and Western Treatment Plant in their raw mixture. The results demonstrate that incorporating 15% of biosolids in 15% of fired-clay brick production would completely alleviate the environmental stress of biosolids stockpiling. In addition, the utilisation of biosolids in brick production would reduce the carbon footprint of brick manufacturing whilst satisfying all the environmental and engineering requirements for bricks.

2. Materials and Methods

The biosolids samples were collected from existing stockpiles at both the ETP (Stock pile No. 22) and WTP (Stock pile No. 10 and Nos. 17–29). Boral Bricks Pty Ltd. provided the brick soil for this investigation (Figure 2).



Figure 2. The storage conditions of the biosolids and close-up views of each sample.

The chemical composition of the brick soil and biosolids were tested by X-ray fluorescence (XRF) using a Bruker AXS S4 pioneer spectrometer. This was in addition to a Bruker X-ray Diffractometer, which was used to characterise their major crystalline phases. The leaching of heavy metals was determined according to the Australian Bottle Leaching Procedure (ABLP) [42]. Laboratory tests to determine the geotechnical properties of the biosolids and brick soil were conducted with the liquid limit, plastic limit, particle size distribution and linear shrinkage determined in accordance with the Australian Standards [43,44]. The organic content was evaluated in accordance with Standards [45]. All tests performed were triplicated and the average values obtained.

Bricks formed from clay and biosolids were manufactured for each sample and incorporated by weight 25% biosolids and 75% brick soil. Control-clay bricks were manufactured with 0% biosolids and 100% brick soil to ensure the reliability of the results. All biosolids samples were oven dried at a temperature of 105 °C for 24 h before being added to the brick soil.

The high calorific nature of the organic content in the biosolids reduces the energy required during firing. Studies have shown that the specific firing energy required per brick is approximately between 2 and 3 MJ kg⁻¹ [46], while the calorific value of the organic content in the biosolids is between 10 and 14 MJ kg⁻¹ [47]. The calculations in this analysis have been determined assuming that the specific firing energy of the bricks is 2 MJ kg⁻¹ and the calorific value of the organic content in the biosolids is approximately 12 MJ kg⁻¹. The estimated energy saved during firing through the incorporation of biosolids in the bricks is calculated using Equation (1) [25].

Energy saved during firing

$$\text{Mass of brick soil per brick: } Q_1 = q \times m_1 \quad (1a)$$

$$\text{Mass of brick soil per brick: } m_2 = m_1 - (m_1 \times \text{OC}) \quad (1b)$$

$$\text{Mass of organic content in clay-biosolids mixture from biosolids only: } m_3 = m_1 \times \text{OC} \quad (1c)$$

$$\text{Energy used to fire one clay-biosolids brick: } Q_2 = q \times m_2 - \text{CV} \times m_3 \quad (1d)$$

$$\text{Energy saved: } Q_1 - Q_2 = q \times m_1 - (q \times m_2 - \text{CV} \times m_3) \quad (1e)$$

$$\text{Energy saved: } \Delta E\% = \frac{Q_1 - Q_2}{Q_1} \times 100\% \quad (1f)$$

where:

$q = 2 \text{ MJ kg}^{-1}$ energy used for brick firing,

$m_1 = 3.3 \text{ kg}$ mass of regular control clay brick (kg),

$m_2 = \text{Mass of brick soil per dry green brick (kg)}$,

$m_3 = \text{Mass of organic content in a clay-biosolids mixture from biosolids only (kg)}$,

$\text{OC} = \text{Percentage of organic content in a mixture from biosolids only (\%)}$,

$\text{CV} = \text{Approximate calorific value of organic content in biosolids} = 12 \text{ MJ kg}^{-1}$.

The optimum moisture content (OMC) of the brick soil and biosolids are adjusted to match the results that would be obtained through gyratory compaction. This method of compaction allows a large number of uniform brick samples to be produced, hereby providing more controlled testing. The Australian State Road Authorities extensively use gyratory compaction and have specified the Gyropac (Figure 3) as the preferred method for compacting specimens to international standards and for research requirements. Compaction is achieved by the simultaneous static compression and shearing actions resulting from the motion of the centre line of the test specimen, while its end remains perpendicular to the axis of the conical surface. The confining pressure and number of gyrations can be pre-set on the hand held control pendant before beginning a test. The angle and rate of gyration were held constant in this study at 3° and 25 gyrations per minute, respectively.



Figure 3. The gyrotory machine used in this study.

Once the OMC was determined, the brick soil and biosolids samples were oven-dried at 105 °C for 24 h. A Hobart mechanical mixer was used for 20 min to ensure that large particles were broken down and that the mixture was smooth. The samples were then compacted with the same compaction pressure of 240 kPa in a mould of 100 mm diameter and 50 mm height. Following this, the green (unfired) bricks were air-dried for 48 h followed by a 24-h oven drying period at 105 °C, before being placed in a muffle furnace with a ramp rate of 0.7 °C/min up to 1100 °C. They were held at this temperature for 3 h, and, after firing the bricks, remained in the furnace until they cooled to room temperature. A series of tests were then conducted to determine the shrinkage, density, compressive strength, water absorption, initial rate of absorption (IRA), weight loss on ignition and potential for efflorescence. All the tests were conducted according to the Australian Standards [48–50].

The effect on the microstructure of the brick samples from adding biosolids was determined using a Philips XL30 scanning electron microscope. The brick samples were mounted on a 25 mm pin stub and then attached using carbon tape. Moreover, the samples were then coated with approximately 20 nm of gold using an SPI sputter coater and analysed.

The possible environmental impacts that may arise due to the leaching of heavy metals were determined according to the Australian bottle leaching procedure (ABLP) method, as prescribed by the Australian Standards [42]. Brick samples were crushed and filtered through a standard 2.4 mm sieve and an applicable extraction fluid was determined by measuring the pH of the test sample. The samples were then obtained through the use of the extraction fluid that was equal to 20 times the weight of the crushed brick particles used in the test. Following this, the samples were secured in an agitation device and rotated at 30 revolutions per minute for 18 h while maintaining a temperature of between 21 and 25 °C. They were then acidified to a pH of < 2 using nitric acid. In turn, the solid phase was separated from the liquid by means of a 0.45 µm filter and analysed for heavy metals using Inductively Coupled Plasma Mass Spectrometry (ICP-MS). This method has been used in the past by many researchers for trace metal analysis [51–55].

3. Results and Discussion

3.1. Characterisation of Biosolids and Brick Soil

X-ray fluorescence (XRF) was used to determine the chemical composition of the brick soil and biosolids samples; the results are presented in Table 1. The most prevalent elements were Silica (SiO₂), Alumina (Al₂O₃) and Ferric Oxide (Fe₂O₃). It should be noted that WTP 17–29 comprised a substantial amount of Sulphur Trioxide (SO₃) in comparison with the brick soil or other biosolids

samples that recorded negligible amounts. Furthermore, the WTP samples contained significantly greater amounts of Calcium Oxide (CaO) than either of the other samples. Other than these two exceptions, the biosolids samples were very similar to the brick soil, and, therefore, have the potential to act as a partial replacement material in bricks.

Table 1. Chemical composition of the brick soil and biosolids samples used in the study (wt.%).

Oxide Content	Brick Soil	ETP 22	WTP 10	WTP 17–29
SiO ₂	64.75	59.43	46.91	41.17
Al ₂ O ₃	19.20	17.60	15.90	13.2
Fe ₂ O ₃	6.60	9.58	8.60	7.018
K ₂ O	4.96	0.91	2.82	1.71
MgO	1.73	1.59	1.35	1.28
TiO ₂	1.14	2.18	2.15	2.07
P ₂ O ₅	1.04	3.66	4.75	6.11
CaO	0.25	2.45	7.70	10.31
SO ₃	-	-	-	12.92

An X-ray diffractometer (XRD) was used to determine the major crystalline phases on a <75 µm sample of the brick soil and biosolids. As expected, all samples conveyed that Quartz (SiO₂) was the leading crystalline phase, with minor changes in the other constituents. The brick soil (Figure 4a) displayed relatively higher levels of Muscovite (KAl₂(AlSi₃O₁₀)(F,OH)₂) and Kaolinite (Al₄(OH)₈(Si₄O₁₀)) than the other samples, while ETP 22 biosolids (Figure 4b) registered notable traces of Hematite (Fe₂O₃), Jacobsite (MnFe₂O₄), and Tosudite ((K,Ca)_{0.8}A₁₆(Si, Al)₈O₂₀(OH)_{10.4}H₂O). Additionally, WTP 10 biosolids (Figure 4c) were shown to comprise Muscovite, Kaolinite and Bassanite (CaSO_{40.5}H₂O) similar to WTP 17-29 (Figure 4d), which also contained Kaolinite and Bassanite.

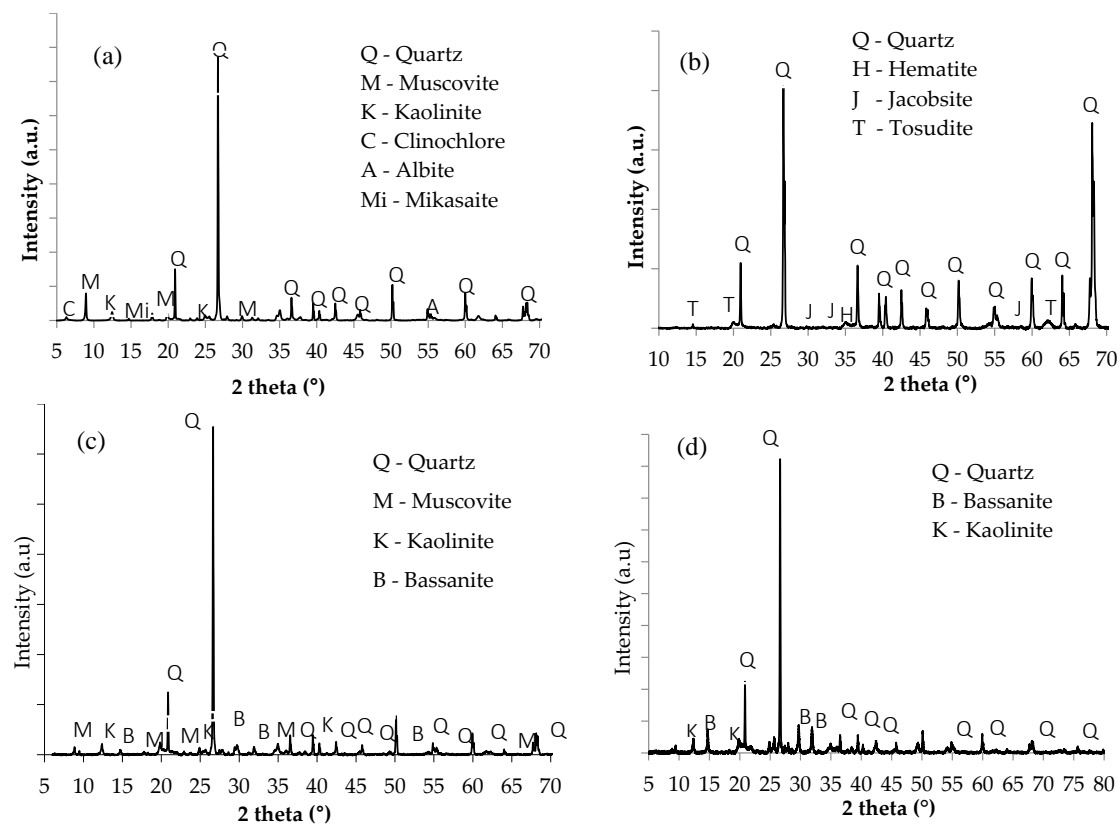

Figure 4. XRF patterns of (a) Brick soil; (b) ETP 22; (c) WTP 10 and (d) WTP 17–29.

3.2. Physical Properties of the Brick Soil and Biosolids Samples

The geotechnical properties of the brick soil and biosolids samples can be found in Table 2. By testing the Atterberg limits it was found that the liquid limit ranged from 53–70% in the biosolids; which is substantially greater than the brick soil at 32%. The plastic limit range of the biosolids samples was also higher than the brick soil at 27–62% compared to 19%. The higher values for the plastic limits and liquid limits correspond to the higher organic content.

The particle size distributions for the samples were determined through sieve analysis and are shown in Figure 5 [56]. It was found that the WTP 10 and WTP 17–29 samples comprised significantly higher gravel content (13.4% and 12.94%, respectively) than ETP 22 (0.4%). In addition, brick soil comprised 24.2% fine particles (<0.075 mm), the highest of all the samples. The coarse fraction of the raw material has a significant impact on the reduction in the shrinkage of fired-clay bricks. Based on these results and those obtained from the Atterberg limits testing, the brick soil, ETP 22 and WTP 17–29 were all classified as clayey sand, while WTP 10 was well-graded silty sand.

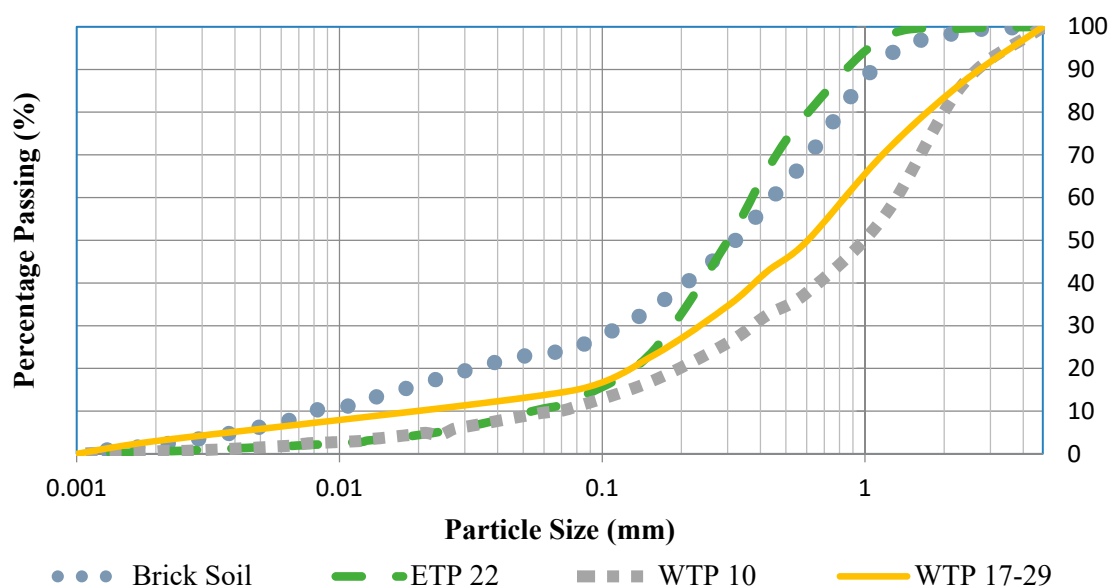

Figure 5. Particle size distribution curves of brick soil and biosolids samples.

Table 2. Geotechnical properties of biosolids samples and brick soil.

Properties	Brick Soil	ETP 22	WTP 10	WTP 17–29
Liquid limit (%)	32	53	54	70
Plastic Limit (%)	19	27	41	62
Plasticity Index (%)	13	26	13	8
Gravel (>2.36 mm) (%)	1.2	0.4	13.4	12.94
Sand (0.075–2.36 mm) (%)	74.6	87.5	76.0	72.37
Silt (0.002–0.075 mm) (%)	22.32	11.6	9.6	12.3
Clay (<0.002 mm) (%)	1.88	0.5	1.0	3.0
Coefficient of uniformity (C_u)	50.00	8.00	18.6	40
Coefficient of curvature (C_c)	4.17	2.00	1.8	3.6
Unified soil classification	SC	SC	SW-SM	SC
Specific gravity	2.69	2.51	2.14	2.03
Linear shrinkage (%)	6.6	14.2	10	6.7
Organic content (%)	1.23	7.1	23.31	27.79

The specific gravity of the biosolids samples and the brick soil was determined in accordance with the appropriate Australian Standards [56]. Kerosene was substituted in preference to deionized or distilled water to avoid dissolving the soluble salts that may exist in the biosolids. The specific

gravity for the brick soil, ETP 22, WTP 10 and WTP 17-29 was found to be 2.69, 2.51, 2.14 and 2.03, respectively. As anticipated, WTP biosolids demonstrated the lowest specific gravity; this was due to the higher levels of organic content [57].

The shrinkage of the raw mixture is an influential indicator for determining the quality of bricks. Shrinkage and strain have a direct relationship, and a higher level of shrinkage increases the likelihood of cracks appearing. Linear shrinkage was calculated by determining the percentage reduction in the length of the bars of soil samples that were prepared at their liquid limit [43,44]. The linear shrinkage of the brick soil, ETP 22, WTP 10 and WTP 17-29 were calculated to be 6.6%, 14.2%, 10% and 6.7%, respectively.

The organic content was determined according to British Standards [45]. The study found that both WTP samples contained substantially greater amounts of organic content than the ETP and brick soil samples. The WTP 17-29 sample comprised the most organic content (27.29%) with WTP 10 recording the second most (23.31%) and ETP 22 third (7.1%), compared to the brick soil (1.23%). Organic matter is prone to burning up during the firing process, which, in turn, leads to higher porosity, and results in decreased density and compressive strength. However, an increase in porosity would improve the thermal insulating properties of the brick, and, therefore, the desirable organic content should balance the engineering properties of the brick with associated environmental consequences.

The optimum moisture content (OMC) of the samples was adjusted for use with the gyratory compaction machine. As shown in Figure 6, the OMC of the clay–soil mixture with 25% ETP biosolids was found to be 17%, while that for the mixture comprising clay–soil and 25% WTP 10, and WTP 17-29 were 20% and 18%, respectively.

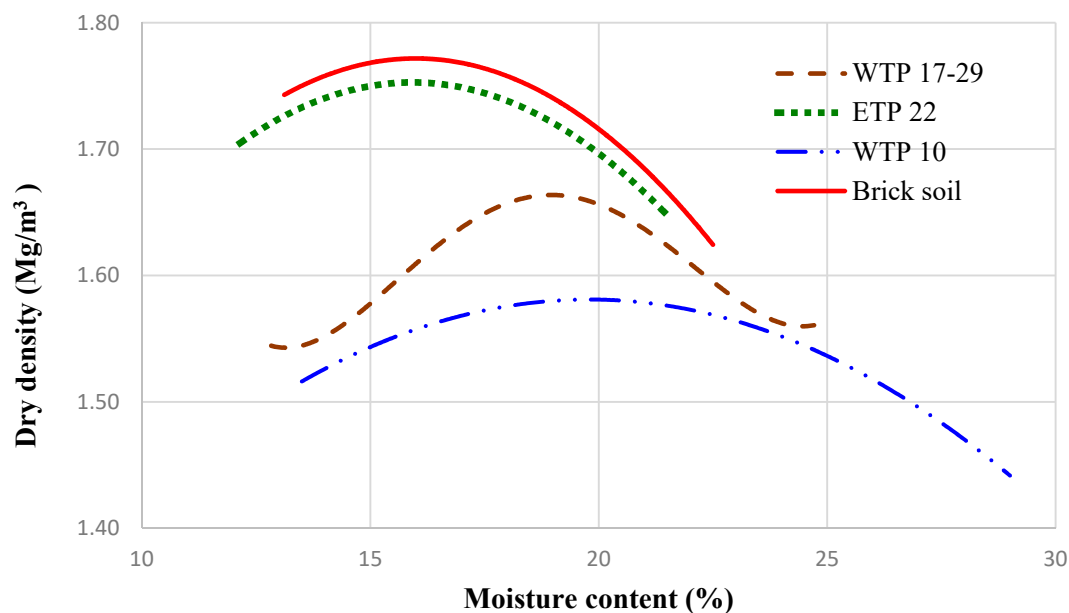

Figure 6. Compaction curves for the brick soil and 25% clay–biosolids mixtures.

3.3. Properties of Bricks

Clay–biosolids bricks comprising 25% by weight of ETP 22, WTP 10 or WTP 17-29 were manufactured alongside 100% clay–soil control bricks (Figure 7).



Figure 7. Samples of manufactured ETP 22, WTP 10 and WTP 17–29 brick samples.

The shrinkage properties of the manufactured bricks were evaluated. The removal of water from the green bricks during the initial drying period causes contraction of the bonding particles with the higher surface area, which eventually results in a decrease in the overall dimensions [58]. This is essential, as greater shrinkage results in an increase in stress in the ceramic body, and, in turn, an increase in the likelihood of cracks to appear [39]. Three brick samples from the control and each of the clay–biosolids batches were measured for initial and firing shrinkage with the average of their values represented in terms of height, diameter and volumetric shrinkage (Table 3).

Table 3. Shrinkage of control and biosolids-amended bricks.

Type of Shrinkage	Type of Brick	Diametric (%)	Height (%)
Initial drying shrinkage	Control	1.26	0.92
	ETP 22	2.28	2.15
	WTP 10	4.48	3.24
	WTP 17–29	2.37	2.6
Firing shrinkage	Control	3.24	3.54
	ETP 22	1.78	1.7
	WTP 10	5.23	4.47
	WTP 17–29	3.0	3.2
Total shrinkage	Control	5	4.46
	ETP 22	4.06	3.85
	WTP 10	9.71	7.71
	WTP 17–29	5.4	5.7

As shown in Table 3, Clay–ETP 22 biosolids bricks showed the lowest firing diametric and height shrinkages with 1.78% and 1.70%, respectively. Conversely, Clay–WTP 10 biosolids bricks showed the highest values in both cases. This was largely due to different organic contents and particle size distributions. Generally, a good quality brick exhibits a total shrinkage of less than 8% [58,59] this benchmark was met by all bricks except the WTP 10 incorporated bricks, which failed in terms of their diametric firing shrinkage (9.71%). In order to improve the result, the initial mixing moisture content and compaction energy used in manufacturing could be reduced. This could also be achieved by decreasing the percentage of WTP 10 biosolids in the mixture.

The densities of the bricks were examined and are shown in Table 4. The control bricks with 0% biosolids recorded the greatest density (2122 kg/m³), while the bricks that incorporated WTP 17–29 recorded the lowest (1866 kg/m³). As the data indicates, clay–biosolids bricks record lower level densities due to having greater amounts of organic content that is burned off during the firing process, which, in turn, increases their porosity.

The weight loss on ignition (LOI) of clay–ETP 22, clay–WTP 10 and clay–WTP 17–29 bricks were 5.5%, 11.3% and 11%, respectively. The control bricks showed the lowest weight loss of 4.7% (Table 4). Due to the organic content in biosolids, an increase in weight loss on ignition is to be expected.

The initial rate of absorption (IRA) takes into account the amount of water that is soaked into the bed face of the brick in 1 minute. Low water infiltration is a contributing factor to the bricks durability and ensures greater resistance to the natural environment. High IRA values should be avoided as they can lead to defects and lower durability. The typical range for the IRA varies between 0.2 and 5 kg/m²/min. All the manufactured bricks in this study satisfied this requirement (Table 4).

Table 4. Physical and mechanical properties of control and 25% biosolids-amended bricks.

Property	Unit	Control Bricks	ETP 22 Bricks	WTP 10 Bricks	WTP 17–29 Bricks
Compressive Strength of brick (25% biosolids)	MPa	41.9	27.9	14.3	12.04
Bulk Density	kg/m ³	2122	2030	1876	1866
IRA	kg/m ² /min	1.83	2.74	3.41	2.64
Weight loss on Ignition (LOI)	%	4.7	5.5	11.3	11.0
Thermal Conductivity	W/m/K	1.09	0.96	0.77	0.75
Average organic content	%	1.23	2.70	6.75	7.87

Compressive strength testing was conducted to determine the structural properties of the bricks. The results indicate that clay–ETP 22 bricks have significantly greater compressive strength (27.9 MPa) than both its WTP 10 and WTP 17–29 counterparts at 14.3 MPa and 12.04 MPa, respectively. An acceptable compressive strength for bricks in most low-rise buildings is about 5 MPa [60,61]. All bricks overwhelmingly satisfied this minimum requirement for the compressive strength. The organic content present in the raw mixture has a significant impact on the compressive strength of the final product. This is a result of the increased porosity due to the thermal destruction of the organic matter. Table 5 provides a comparison of the compressive strengths expected from bricks that incorporate varying percentages of biosolids.

Table 5. Comparison of compressive strength of control bricks and bricks incorporating varying percentages of biosolids.

Compressive Strength for Different Parentage of Biosolids	Unit	Control Bricks	ETP 22 Bricks	WTP 10 Bricks	WTP 17–29 * Bricks
Compressive Strength (25% biosolids)	MPa	41.9	27.9	14.3	12.04
Compressive Strength (20% biosolids)	MPa	41.9	30.6	16.5	15.4
Compressive Strength (15% biosolids)	MPa	41.9	32.0	19.1	16.9
Compressive Strength (10% biosolids)	MPa	41.9	35.5	23.7	21.5

* Note: The results for WTP 17–29 for 20, 15 and 10% have been taken from Figure 8.

Some of the published and unpublished results from this study have been used to derive Figures 8 and 9, which illustrate the strong correlation between compressive strength and density with respect to organic content. The obtained R² values of 0.89 and 0.93, respectively, indicate strong direct relationships.

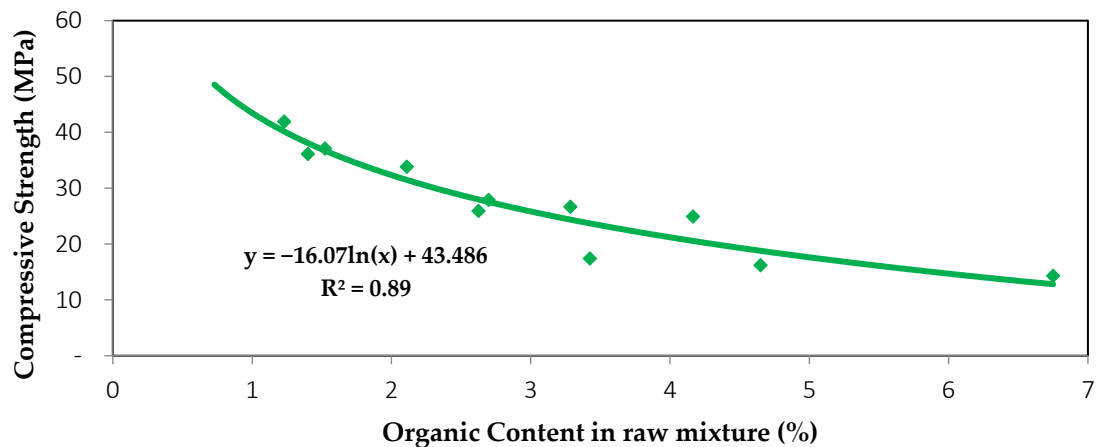

Figure 8. Variation of compressive strength of bricks with organic content in the raw mixture.

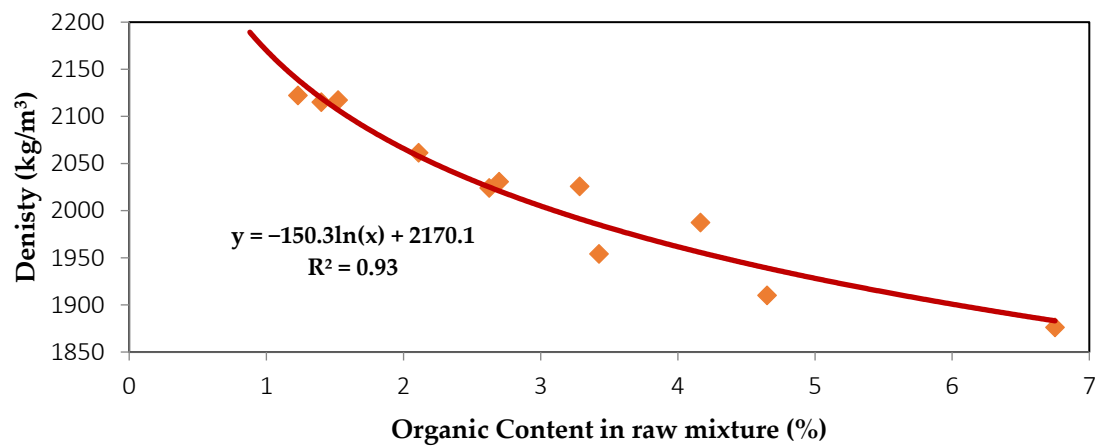

Figure 9. Variation of density of bricks with organic content in the raw mixture.

The bricks were also analysed for water absorption. The values for 24-h water absorption in cold water (A_c) and 5-h absorption in boiling water (A_b) were determined, and the results are presented in Table 6. The saturation coefficient (SC) is the ratio of absorption by 24-h submersion in cold water to that after 5-h submersion in boiling water. The water absorption results for the biosolids-amended bricks and control bricks were in agreement with the ASTM C62 [62] standard specification for building bricks. The 5-h boiling water absorption of all bricks was far below the maximum acceptable limit of 17% for bricks exposed to severe weathering (SW).

Table 6. Water absorption properties of manufactured 25% biosolids-amended bricks.

Brick Type	Cold Water Absorption % (A_c)	Boiling Water Absorption % (A_b)	Saturation Coefficient (SC)	ASTM Grade
Control Bricks	7.5	8.5	0.88	SW
ETP 22	9.8	11.0	0.89	SW
WTP 10	9.4	11.5	0.82	SW
WTP 17–29	13	14.3	0.91	SW

Efflorescence is the crystallisation of soluble salts that leak from the interior of the brick to its surface. This phenomenon is an aesthetic issue that appears as a thin white salt deposit on the surface of porous building materials [61,63]. To evaluate the efflorescence potential, brick samples were placed in distilled water and allowed to soak through for 7 days. The water level was maintained at 25 ± 5 mm depth and then samples were air dried for 2 days and compared with specimens that

were not subjected to soaking. It was found that the ETP 22 biosolids bricks (Figure 10b) had “slight efflorescence” according to the Australian standards [50]. All other samples recorded no observable efflorescence. The efflorescence tendencies of the samples are shown in Figure 10.

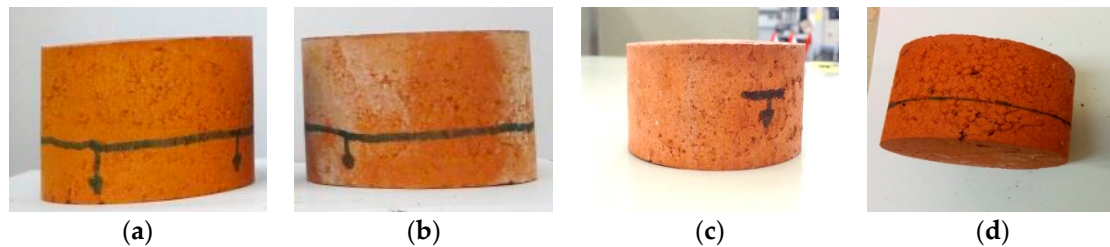

Figure 10. Efflorescence on (a) Control brick; (b) ETP amended brick; (c) WTP amended brick; (d) WTP 17–29 amended brick.

Thermal conductivity was estimated using Equation (2), which was developed in a previous study [25]. This equation was developed using 256 test results for the thermal conductivity of different types of brick, concrete and aggregate.

$$T = 0.0559e^{0.0014D_d}R^2 = 0.885 \quad (2)$$

where:

T = Thermal conductivity (W/m/k)

Dd = Dry density of the bricks (kg/m³).

The estimated thermal conductivity of the control bricks was higher than that of the biosolids bricks. The thermal conductivity of the ETP 22, WTP 10 and WTP 17–29 25% biosolids-amended bricks decreased by approximately 12%, 29% and 39%, respectively, when compared to that of the control bricks (Table 4). Thermal conductivity is an essential component in gauging energy saving due to its thermal insulating abilities. A low thermal conductivity corresponds to greater insulating properties of a material. As evident from the results presented in Table 4, it was found that there is a strong direct relationship between the density and thermal conductivity.

3.4. Macrostructure of Bricks

The captured SEM images of the control brick and the three biosolids-amended bricks are shown in Figure 11. The frequency and size of the pores increase in the clay-biosolids bricks. The increase in porosity is due to the thermal destruction of organic matter during the firing stage. Due to this, lightweight bricks with lower strength can be expected which has been revealed in the density and compressive strength results.

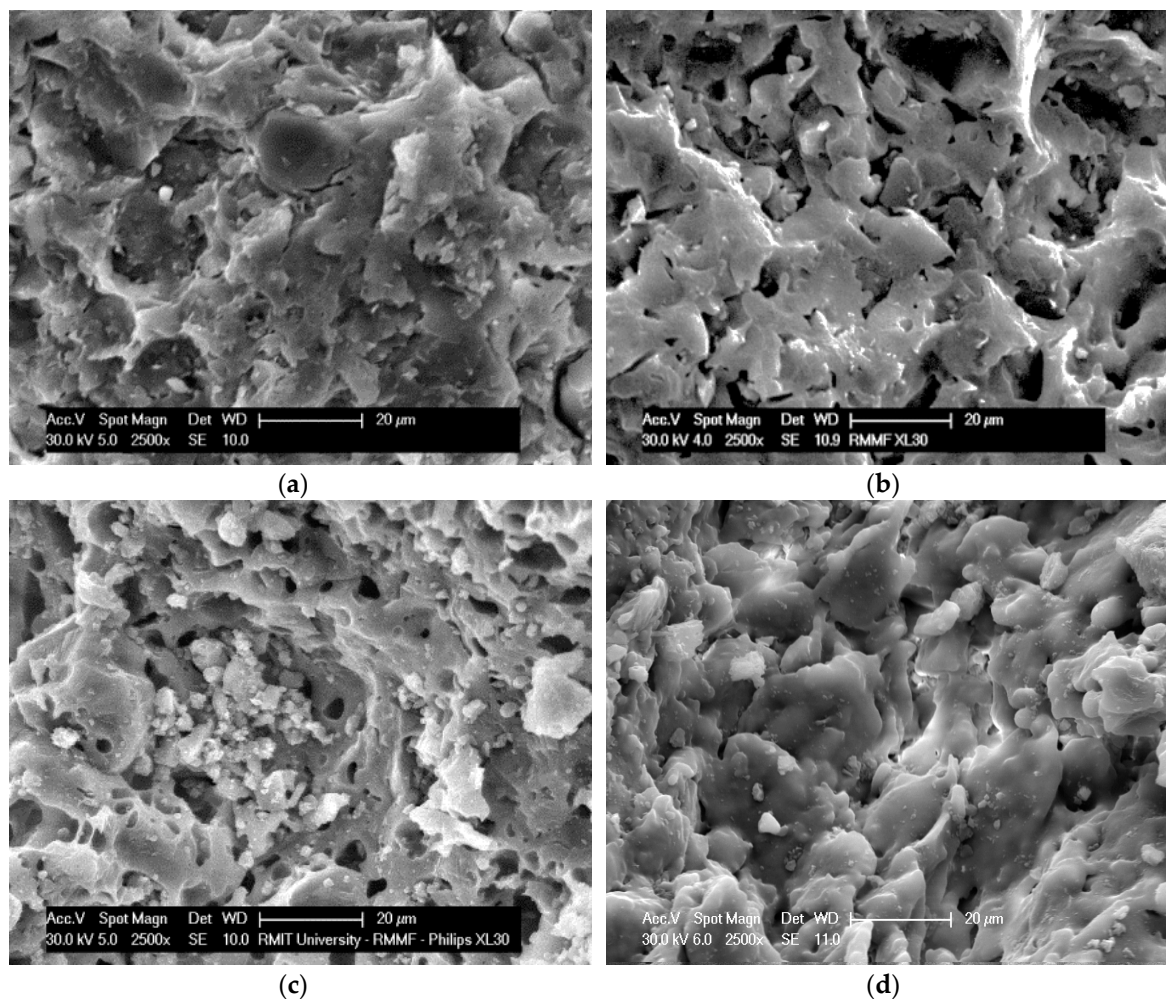

Figure 11. SEM images of (a) Control brick; (b) 25% amended ETP 22 brick; (c) 25% amended WTP 10 brick and (d) 25% amended WTP 17–29 brick.

3.5. Leachate Analysis

The comprehensive leachate results from this study indicate that the leaching of heavy metals from fired bricks was significantly lower than that for the unfired samples. Between 43–99% of heavy metals tested (As, Ag, Ba, Be, Cd, Cr, Cu, Mo, Ni, Pb, Sb, Se, and Zn) were immobilized inside all the fired bricks compared to the unfired green bricks.

The leaching of heavy metals from the brick soil, biosolids samples and the fired bricks were determined using the ABLP method, and the results are shown in Tables 7 and 8. From the results, it can be seen that the heavy metal concentrations are insignificant compared with regulatory benchmarks for potable water and solid waste materials [64–68]. The limits for potable water have been included for reference.

The ABLP tests for the green and fired bricks presented in this study were performed for single standard pH and liquid-to-solid ratio values. According to these results, it can be anticipated that biosolids-amended bricks are safe under various states of pH and liquid-to-solid ratio, because the concentrations of heavy metals in both green bricks and fired bricks are far below the regulatory benchmarks shown. However, the tests conducted may not be sufficient for characterizing leaching over the range of possible environmental conditions expected in various different uses or disposal scenarios, or over the lifetime of materials subject to shifting environmental conditions [69–71]. The framework and methodologies first proposed by Kosson et al. in 2002 [72], and published

in 2013 by US EPA as new test methods [71,73], are strongly recommended for assessing the leachates of heavy metals from secondary materials such as waste-amended bricks.

Table 7. Leachate test results for fired–clay bricks with 25% biosolids.

Heavy Metal	Concentration Limit (mg/L) *	Concentration Limit (mg/L) **	Detected Concentrations (mg/L)			
			Control Brick	ETP 22 Brick	WTP 10 Brick	WTP 17–29 Brick
Sb	0.006	N/A	<0.01	<0.01	<0.01	<0.01
As	0.01	0.01	<0.01	0.01	0.1	0.21
Ba	2	2	0.22	0.23	0.14	0.15
Be	0.004	0.06	<0.01	<0.01	<0.01	<0.01
Cd	0.005	0.002	<0.002	<0.002	<0.002	0.002
Cr	0.1	0.05	<0.01	<0.01	<0.01	0.01
Cu	1.3	2	0.11	0.04	0.05	0.31
Pb	0.015	0.01	<0.01	<0.01	<0.01	0.01
Mo	N/A	0.05	<0.01	<0.01	0.04	0.06
Ni	N/A	0.02	<0.01	<0.01	0.01	<0.01
Se	0.05	0.01	<0.01	<0.01	<0.01	<0.01
Ag	N/A	0.1	<0.01	<0.01	<0.01	<0.01
Zn	N/A	N/A	0.09	0.02	0.14	0.12

* Limits for inorganic chemicals in potable water [64]. ** Limits for inorganic chemicals in potable water [65].

Table 8. Leachate test results for the brick soil and biosolids.

Heavy Metal	Concentration Limit (mg/L) *	Detected Concentrations (mg/L)			
		Brick Soil	ETP 22	WTP 10	WTP 17–29
Sb	8	<0.01	0.01	0.06	0.06
As	2.8	<0.01	0.02	0.02	0.06
Ba	280	0.18	0.03	0.12	0.05
Be	4	<0.01	<0.01	<0.01	<0.01
Cd	0.8	<0.002	0.009	0.013	0.17
Cr	20	<0.01	<0.01	0.01	0.10
Cu	800	<0.01	0.18	0.33	1.6
Pb	4	0.01	<0.01	<0.01	0.04
Mo	20	<0.01	<0.01	0.13	0.05
Ni	8	<0.01	0.14	0.21	0.78
Se	4	<0.01	<0.01	0.01	0.02
Ag	40	<0.01	<0.01	<0.01	<0.01
Zn	1200	0.03	1.4	3.1	18

* ABLP Limits (Industrial Waste Resource Guidelines [66]).

3.6. Energy Saved during Firing

Equation (1f) allows us to estimate the amount of energy saved when firing clay–biosolids bricks due to the contribution of the organic content in the biosolids. The results calculated from this equation are noted in Tables 9 and 10, and convey that with a 25% contribution of WTP 17–29 into a regular fired–clay brick, a 48.6% energy saving can be made during firing. This figure is extremely encouraging, as the 25% contribution of biosolids used in this study complies with all the regulatory standards, as discussed in previous sections, and would save up to 50% of the total firing energy used. This would act to greatly reduce the carbon footprint of brick-manufacturing companies.

The significant saving in firing energy is due to the substantial amount of organic content found in biosolids. It reduces the firing energy required by aiding the generation of heat inside the furnace.

Table 9. Sample computations for determining the percentage of energy saved during the firing of bricks containing 25% biosolids.

Biosolids Sample	Average Organic Content in Raw Mixture (%)	m ₁ (kg)	m ₂ (kg)	m ₃ (kg)	Q ₁ (MJ kg ⁻¹)	Q ₂ (MJ kg ⁻¹)	ΔE* (%)
ETP 22	1.78	3.3	3.241	0.059	6.6	5.78	12.4%
WTP 10	5.83	3.3	3.108	0.192	6.6	3.908	40.1%
WTP 17-29	6.95	3.3	3.071	0.229	6.6	3.390	48.6%

* ΔE has been derived using Equation (1g).

Table 10. Approximate percentage of energy saved during firing of clay–biosolids bricks.

Biosolids (%)	Energy Saved (%)		
	ETP 22	WTP 10	WTP 17–29
5	2.5	8.2	9.7
10	5.0	16.3	19.5
15	7.5	24.5	29.2
20	9.9	32.6	38.9
25	12.4	40.8	48.6
30	14.9	49.0	58.4
35	17.4	57.1	68.1
40	19.9	65.3	77.8
45	22.4	73.4	87.5
50	24.9	81.6	97.3

Figure 12 illustrates the theoretical saving of energy during firing when incorporating different percentages of biosolids into the brick mixture. The amount of biosolids that can be used in the mixture depends on its organic content as it is the distinguishing factor in determining the physical, mechanical and chemical properties of the bricks [57,74]. In this study, it was determined that bricks incorporating 25% biosolids from the ETP 22, WTP 10 and WTP 17–29 stockpiles meet and surpass all the applicable standards regarding brick performance.

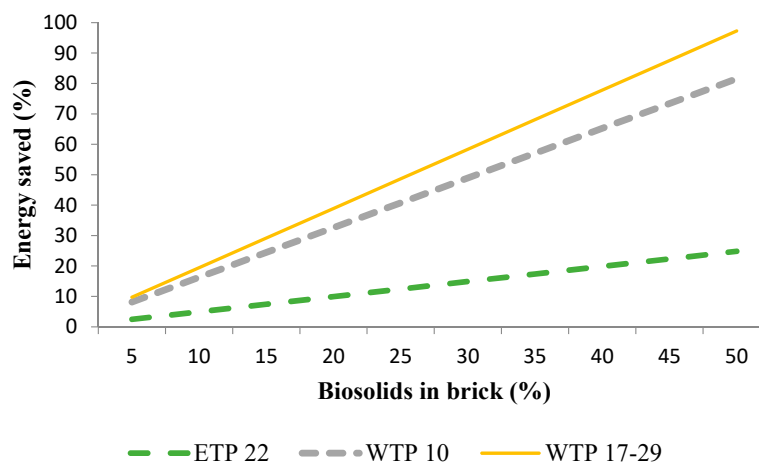
**Figure 12.** Percentage of energy saved during firing of clay–biosolids bricks.

3.7. Environmental Impacts

The addition of biosolids to global brick production is a promising approach for preventing the greenhouse gas emissions and land demand of biosolid stockpiles. In addition, the possible energy savings during the firing process of biosolids-amended bricks positively affect the environmental impacts of brick production. Incorporating biosolids into bricks also reduces the demand for the excavation of large amounts of virgin soil from the earth's crust.

The environmental impact associated with the production of conventional bricks compared to bricks incorporating different percentages of ETP and WTP biosolids has been studied as part of a life cycle assessment (LCA) study of biosolids-amended bricks, using SimaPro software (version 8.0.5.13) [10]. The scope of the LCA study ranges from “cradle to gate”, which involves the clay and biosolids extraction, transportation, crushing and proportioning, grinding and screening, brick shaping, drying, firing and packaging. The energy used and the emissions produced have been quantified, and the potential environmental impacts were assessed and compared. The LCA results show that the incorporation of biosolids into bricks is a positive and promising alternative approach with respect to all the environmental impacts of biosolids treatment and brick manufacturing [10,75].

The LCA results indicate that biosolids can be utilised as an environmentally friendly replacement material for clay in fired clay bricks. This statement is supported by the results of this study, which demonstrate the entrapment of leachates within the bricks during the firing process. In addition, the LCA found that the embodied energy of biosolids bricks are significantly lower than that of conventional fired clay bricks without replacement materials. It was also found that biosolids bricks achieved better long-term environmental performance in terms of acidification and ozone depletion impacts. In summary, the LCA results indicate that the incorporation of biosolids in bricks significantly reduces all negative environmental impacts when compared to control bricks, with the exception of water depletion impact. It should be noted that the distance of biosolid stockpiles from manufacturing plants will affect these results.

4. Proposal

This study proposes the inclusion of a minimum of 15% biosolids content in 15% of global brick production in order to recycle all leftover biosolids and to reduce the demand for excavated soil.

In Australia, 30% of the 300 thousand dry tonnes of biosolids produced are stockpiled each year—equating to about 90 thousand dry tonnes [1]. Australia also produces approximately 1.31 billion bricks each year. Estimating an average mass of 3.2 kg per brick, the total mass of bricks produced is therefore 4.192 million tonnes. Utilising 15% of this total to incorporate biosolids means that 628.8 thousand tonnes of brick production should include biosolids. Recycling biosolids into 15% of 628.8 thousand tonnes of brick mixture would recycle approximately 94.32 thousand tonnes of excess biosolids. This is greater than the estimated amount of annually unused biosolids in Australia, and, therefore, could help achieve the depletion of existing biosolids stockpiles and account for future increases in biosolids production. In addition, brick production would have significant energy savings during the firing process, varying from 12.4% to 48.6% for biosolids with organic contents of 7.1% to 27.79%.

The bricks incorporating only 15% of biosolids used in this study, are excellent quality bricks, suitable for use as standard high-quality bricks (Table 11). The results from this study show that up to 25% biosolids can be incorporated for manufacturing normal bricks.

Table 11. Estimated properties and energy savings of 15% biosolids content bricks from this study.

Biosolids	Compressive Strength (MPa)	Energy Savings (%)	Organic Content of Biosolids (%)	Average Organic Content of Raw Mixture (%)	Bulk Density of Bricks kg/m ³
Control	41.9	0.0	0.00	1.23	2122
ETP 22	32.0	7.5	7.10	2.11	2058
WTP 10	19.1	24.5	23.31	4.54	1943
WTP 17–29	16.9	29.2	27.79	5.21	1922

Incorporating biosolids into global brick production would also save a substantial amount of virgin soil from being excavated, which offers further environmental incentive for recycling biosolids in clay-fired bricks.

Over 1500 billion bricks are produced globally [26], with Asia being the largest producer. Concurrently, the entire world produces significant amounts of biosolids that are deposited into stockpiles.

The production of bricks that incorporate biosolids is very simple and easily achieved. Brick producers will need to source biosolids from local stockpiles. The biosolids retrieved need to be from below the root zone to avoid extra organic matter from grass growing on the top layer of the stockpile. Biosolids samples must then be transported to the brick production site and added to the mixture of excavated clay and soil prior to the crushing and grinding of the raw materials. Approved local recommended safety requirements for excavation, transportation and handling biosolids should be adhered to.

As can be seen from this study, the mechanical properties of biosolids bricks are directly related to the organic content contributed from the inclusion of biosolids. Around the world, biosolids are produced in different environments, treated utilizing varying methods and stored in conditions which will not necessarily be similar or identical to those used in this study. As a result, it is essential that small-scale localised testing of biosolids be undertaken prior to incorporation in bricks, so that the organic and chemical contents of local unused biosolids is known. With this information, the expected performance of the bricks can be determined from Figure 8. This is an essential first step in identifying suitable biosolids stockpiles for recycling in fired-clay bricks.

Leachate concentrations from the biosolids bricks were found to be insignificant, for the biosolids samples used in this study [76]. Biosolids could have significantly different chemical characteristics depending on the origin of the wastewater and the treatment procedure. Therefore, it is essential that suitable leachate analysis be undertaken on test bricks before large scale production is endorsed according to US EPA methods 1314 and 1315, which shall explore the leaching behaviour of heavy metals at different liquid-to-solid ratios and pH values [71,73,77].

5. Conclusions

This study has investigated the potential of incorporating biosolids into the raw material of clay-fired bricks. The chemical, physical and mechanical properties of bricks incorporating 25%, 20%, 15% and 10% by weight of biosolids samples, sourced from Melbourne Water's Eastern and Western treatment plants (ETP 22, WTP 10 & WTP 17–29), were evaluated.

Organic content is the most important variable for the mechanical performance of the biosolids-amended bricks. SEM analysis confirmed that organic matter in bricks is burned away during firing, resulting in the development of greater pore volume. The increase in pore volume ultimately resulted in lower compressive strength values, reduced density and increased shrinkage for the biosolids-amended bricks compared to the control bricks. Average compressive strength testing results were between 35.5 MPa and 12.04 MPa for the bricks incorporated with 10% to 25% biosolids respectively. Acceptable compressive strength for bricks in most low-rise buildings is about 5 MPa.

In determining the geotechnical properties of the biosolids samples, it was found that ETP 22 and WTP 17–29 are classified as clayey silty sand and silty sand, respectively, while WTP 10 is well-graded silty gravelly sand. Importantly, the WTP samples were found to contain significantly more organic content than the ETP sample. The chemical characterisation of the biosolids samples and brick soil was determined through the use of X-ray fluorescence and X-ray diffraction. The results obtained convey no abnormalities that would hinder their suitability as a clay-replacement material. In fact, the composition of biosolids is very similar to the clay used in brick manufacturing.

The increased organic content also resulted in a drop in thermal conductivity for the biosolids samples. The ETP 22 clay-biosolids brick recorded 0.96 W/m/K, significantly higher than the WTP 10 and WTP 17–29 clay-biosolids bricks (0.77 W/m/K and 0.75 W/m/K, respectively) but lower than the control brick (1.09 W/m/K). Lower thermal conductivity would enhance the insulating abilities of the bricks. The contribution of the organic content to energy savings during firing was also estimated and conveys extremely positive results. Utilising biosolids in fired-clay bricks can save up to 48.6% of the firing energy for the biosolids samples used in this study.

Efflorescence testing also recorded positive results with all brick samples. Additionally, the water absorption of the bricks was found to comply with the requirement for building bricks. Furthermore, a leachate analysis was conducted to determine the amount of leaching of heavy metals from the ceramic body. The results indicate that between 43 and 99% of heavy metals in the raw mixture are immobilised in the brick after firing. Leachate concentrations from both the biosolids and biosolids bricks were found to be insignificant, for the biosolids samples used in this study.

The environmental impact associated with the production of conventional bricks compared to bricks incorporating different percentages of ETP and WTP biosolids have been studied as part of a Life Cycle Assessment (LCA) study of biosolids-amended bricks. The emissions study and comparative Life Cycle Assessment results show that the inclusion of biosolids in fired-clay bricks appears to have promising and significant positive benefits for the environment.

Based on the results found in this study, recycling biosolids in fired-clay bricks would significantly reduce the carbon footprint of brick production. In addition, brick production would have significant energy savings during the firing process, varying from 12.4% to 48.6% for biosolids with organic contents of 7.1% to 27.79%, as used in this study.

Bricks incorporating only 15% biosolids are excellent quality clean bricks suitable for use as standard high-quality bricks, for biosolids with organic contents up to about 35%. Furthermore, inclusion of biosolids into bricks also reduces the ongoing and growing demand for the excavation of large amounts of virgin soil from the earth's crust.

Author Contributions: A summary of each author's contribution to this work is provided below. Conceptualization, Supervision, Project leader and administration: A.M.; Original commencing research group: A.M., N.E., S.S.; Methodology: A.M., A.U.; Major Laboratory investigation and data analysis: A.U. under the supervision of A.M.; Laboratory investigation: M.S., M.A.; Data analysis: A.M., A.U., T.J.-B. and M.S.; LCA: A.U., A.M.; Literature review: A.M., A.U., T.J.-B., G.R. and S.B.; Writing, editing and reviewing: A.M., T.J.-B., G.R., A.U. and S.B.; Contribution to Supervision: N.E. and S.S.

Funding: This research received external funding from Melbourne Water, Australia.

Acknowledgments: The authors would like to thank Melbourne Water, RMIT University and Australian Government Research Training Program scholarship for their financial and in-kind support. In addition, the technical assistance of the Civil and Chemical Engineering and Rheology and Materials Characterization laboratories, and Microscopy and Microanalysis Facility, RMIT University, is gratefully acknowledged. Also, the authors are very grateful to Boral Bricks Pty Ltd. and PGH Bricks and Pavers (Victoria) for their support in providing the brick soil for this research.

Conflicts of Interest: The authors declare no conflicts of interest.

Abbreviations

ETP	Eastern treatment plant
WTP	Western treatment plant
SEM	Scanning electron microscopy
XRF	X-ray fluorescence
XRD	X-ray diffraction
ABLP	Australian bottle leaching procedure
OC	Organic content
CV	Calorific value
OMC	Optimum moisture content
LOI	Weight loss on ignition
IRA	Initial rate of absorption
A _c	Cold water absorption
A _b	Boiling water absorption
SC	Saturation coefficient
R ²	Coefficient of correlation
SW	Severe weathering

References

1. ANZBP. What Are Biosolids? Australian Water Association. 2018. Available online: <https://www.biosolids.com.au/info/what-are-biosolids/> (accessed on 28 December 2018).
2. Lyberatos, G.; Sklyvaniotis, M.; Angelakis, A. Management of biosolids in EU countries: Challenges and Prospective. *Fresenius Environ. Bull.* **2011**, *20*, 2489–2495.
3. Davis, R.; Slaughter, B. *Biosolids Management: Options, Opportunities and Challenges*; NACWA: Washington, DC, USA, 2006.
4. Rigby, H.; Clarke, B.O.; Pritchard, D.L.; Meehan, B.; Beshah, F.; Smith, R.S.; Porter, N.A. A critical review of nitrogen mineralization in biosolids-amended soil, the associated fertilizer value for crop production and potential for emissions to the environment. *Sci. Total Environ.* **2016**, *541*, 1310–1338. [CrossRef] [PubMed]
5. AWA. *The Management of Biosolids in Australia*; Australian Water Association: Sydney, Australia, 2012.
6. EPA Victoria. *Guidelines for Environmental Management—1288; Use of Biosolids as Geotechnical Fill*; EPA Victoria: Melbourne, Australia, 2009.
7. Melbourne Water. Waste to Resources. 2016. Available online: <https://www.melbournewater.com.au/community-and-education/about-our-water/liveability-and-environment/waste-resources> (accessed on 28 December 2018).
8. Rulkens, W. Sewage Sludge as a Biomass Resource for the Production of Energy: Overview and Assessment of the Various Options. *Energy Fuels* **2007**, *22*, 9–15. [CrossRef]
9. Australian Government. National Waste Reporting 2013: Factsheet—Biosolids Profile. Department of the Environment and Energy, 2013. Available online: <http://www.environment.gov.au/system/files/resources/0a517ed7-74cb-418b-9319-7624491e4921/files/factsheet-biosolids.pdf> (accessed on 18 December 2018).
10. Mohajerani, A.; Ukwatta, A.; Setunge, S. Fired-Clay Bricks Incorporating Biosolids: A Comparative Life Cycle Assessment. *J. Mater. Civ. Eng.* **2018**, *30*, 1–12. [CrossRef]
11. D’Andrea, A.; Fustaino, C.; Tozzo, C. Recycling dredged sludge in asphalt pavement. *J. Mater. Civ. Eng.* **2014**, *26*, 05014005. [CrossRef]
12. Mohajerani, A.; Lound, S.; Liassos, G.; Kurmus, H.; Ukwatta, A.; Nazari, M. Physical, mechanical and chemical properties of biosolids and raw brown coal fly ash, and their combination for road structural fill applications. *J. Clean. Prod.* **2017**, *166*, 1–11. [CrossRef]
13. Paravithana, S.; Mohajerani, A. Effects of recycled concrete aggregates on properties of asphalt concrete. *Resour. Conserv. Recycl.* **2006**, *48*, 1–12. [CrossRef]
14. Arulrajah, A.; Maghoolpilehrood, F.; Disfani, M.M.; Horpibulsuk, S. Spent coffee grounds as a non-structural embankment fill material: Engineering and environmental considerations. *J. Clean. Prod.* **2014**, *72*, 181–186. [CrossRef]
15. Mohajerani, A.; Tanriverdi, Y.; Nguyen, B.; Wong, K.; Dissanayake, H.; Johnson, L.; Whitfield, D.; Thomson, G.; Alqattan, E.; Rezaei, A. Physico-mechanical properties of asphalt concrete incorporated with encapsulated cigarette butts. *Constr. Build. Mater.* **2017**, *153*, 69–80. [CrossRef]
16. Mohajerani, A.; Vajna, J.; Cheung, T.; Kurmus, H.; Arulrajah, A.; Horpibulsuk, S. Practical recycling applications of crushed waste glass in construction materials: A review. *Constr. Build. Mater.* **2017**, *156*, 443–467.
17. Disfani, M.M.; Arulrajah, A.; Suthagaran, V.; Bo, M.W. Geotechnical characteristics of recycled glass-biosolids mixtures. In Proceedings of the 17th International Conference on Soil Mechanics and Geotechnical Engineering, Alexandria, Egypt, 5–9 October 2009; Hamza, M., Shahien, M., El-Mossallamy, Y., Eds.; IOS Press: Amsterdam, The Netherlands, 2009.
18. Disfani, M.; Arulrajah, A.; Suthagaran, V.; Bo, M. Shear strength behavior of recycled glass-biosolids mixtures. In Proceedings of the 62nd Canadian Geotechnical Conference and 10th Joint CGS/IAH-CNC Groundwater Conference, Halifax, NS, Canada, 20–24 September 2009.
19. Arulrajah, A.; Disfani, M.M.; Suthagaran, V.; Bo, M.W. Laboratory Evaluation of the Geotechnical Characteristics of Wastewater Biosolids in Road Embankments. *J. Mater. Civ. Eng.* **2013**, *25*, 1682–1691. [CrossRef]
20. Maghoolpilehrood, F.; Disfani, M.M.; Arulrajah, A. Geotechnical characteristics of aged biosolids stabilized with cement and lime. *Aust. Geomech. J.* **2013**, *48*, 113–120.

21. Kadir, A.A.; Mohajerani, A. Bricks: An Excellent Building Material for Recycling Wastes—A Review. In Proceedings of the IASTED International Conference on Environmental Management and Engineering (EME 2011), Calgary, AB, Canada, 4–6 July 2011; pp. 108–115.
22. Raut, S.P.; Ralegaonkar, R.V.; Mandavgane, S.A. Development of sustainable construction material using industrial and agricultural solid waste: A review of waste-create bricks. *Constr. Build. Mater.* **2011**, *25*, 4037–4042. [[CrossRef](#)]
23. Muñoz Velasco, P.; Morales Ortíz, M.P.; Mendiivil Giró, M.A.; Muñoz Velasco, L. Fired clay bricks manufactured by adding wastes as sustainable construction material—A review. *Constr. Build. Mater.* **2014**, *63*, 97–107. [[CrossRef](#)]
24. Veisesh, S.; Yousefi, A.A. The use of polystyrene in lightweight brick production. *Iran. Polym. J.* **2003**, *12*, 323–329.
25. Mohajerani, A.; Kadir, A.; Larobina, L. A practical proposal for solving the world’s cigarette butt problem: Recycling in fired clay bricks. *Waste Manag.* **2016**, *52*, 228–244. [[CrossRef](#)]
26. Weyant, C.; Athalye, V.; Ragavan, S.; Rajarathnam, U.; Lalchandani, D.; Maithel, S.; Baum, E.; Bond, T.C. Emissions from South Asian Brick Production. *Environ. Sci. Technol.* **2014**, *48*, 6477–6483. [[CrossRef](#)]
27. Australian Bureau of Statistics. Production of Selected Construction Materials. Belconnen, ACT 2616: Australian Bureau of Statistics. 2014. Available online: <http://www.abs.gov.au/ausstats%5Cabs@.nsf/0/EE82154EA7605B0CCA256B5C007900AF?Opendocument> (accessed on 27 January 2015).
28. Liew, A.G.; Idris, A.; Wong, C.H.; Samad, A.A.; Noor, M.J.M.; Baki, A.M. Incorporation of sewage sludge in clay brick and its characterization. *Waste Manag. Res.* **2004**, *22*, 226–233. [[CrossRef](#)]
29. Sutcu, M.; Akkurt, S. The use of recycled paper processing residues in making porous brick with reduced thermal conductivity. *Ceram. Int.* **2009**, *35*, 2625–2631. [[CrossRef](#)]
30. Tay, J.H. Sludge as brick making material. In Proceedings of the New Directions and Research in Waste Treatment and Residual Management, Vancouver, BC, Canada, 23–28 June 1985; pp. 661–688.
31. Tay, J. Bricks Manufactured from Sludge. *J. Environ. Eng.* **1987**, *113*, 278–284. [[CrossRef](#)]
32. Wiebusch, B.; Seyfried, C.F. Utilization of sewage sludge ashes in the brick and tile industry. *Water Sci. Technol.* **1997**, *36*, 251–258. [[CrossRef](#)]
33. Schirmer, T.; Mengel, K.; Wiebusch, B. Chemical and mineralogical investigations on clay bricks containing sewage sludge ash. *Tile Brick Int.* **1999**, *15*, 166–174.
34. Liew, A.G.; Idris, A.; Samad, A.A.; Wong, C.H.K.; Jaafar, M.S.; Baki, A.M. Reusability of sewage sludge in clay bricks. *J. Mater. Cycles Waste Manag.* **2004**, *6*, 41–47. [[CrossRef](#)]
35. Tay, J.; Show, K.; Hong, S. The application of industrial sludge and marine clay in brick-making. *J. Chin. Inst. Environ. Eng.* **2001**, *11*, 203–208.
36. Kayali, O. High Performance Bricks from Fly Ash. In Proceedings of the World of Coal Ash Conference, Lexington, Kentucky, 11 April 2005.
37. Rahman, M.A. Properties of clay-sand-rice husk ash mixed bricks. *Int. J. Cem. Compos. Lightweight Concr.* **1987**, *9*, 105–108. [[CrossRef](#)]
38. Malhotra, S.K.; Tehri, S.P. Development of bricks from granulated blast furnace slag. *Constr. Build. Mater.* **1996**, *10*, 191–193. [[CrossRef](#)]
39. Demir, I. Effect of organic residues addition on the technological properties of clay bricks. *Waste Manag.* **2008**, *28*, 622–627. [[CrossRef](#)]
40. Menezes, R.R.; Ferreira, H.S.; Neves, G.A.; Lira, H.D.L.; Ferreira, H.C. Use of granite sawing wastes in the production of ceramic bricks and tiles. *J. Eur. Ceram. Soc.* **2005**, *25*, 1149–1158. [[CrossRef](#)]
41. Dondi, M.; Guarini, G.; Raimondo, M.; Zanelli, C. Recycling PC and TV waste glass in clay bricks and roof tiles. *Waste Manag.* **2009**, *29*, 1945–1951. [[CrossRef](#)]
42. AS 4439.3. *Wastes, Sediments and Contaminated Soils*; Part 3: Preparation of Leachates-Bottle Leaching Procedure; Standards Australia International Ltd.: Sydney, Australia, 1997.
43. AS 1289.0. *Method of Testing Soils for Engineering Purposes*; Part 0: General Requirements and List of Methods; Standards Australia International Ltd.: Sydney, Australia, 2000.
44. AS 1289.3.4.1. *Methods of Testing Soils for Engineering Purposes—Soil Classification Tests*; Determination of the Linear Shrinkage of a Soil—Standard Method; Standards Australia International Ltd.: Sydney, Australia, 2008.

45. BS 1377-3. *Methods of Test for Soils for Civil Engineering Purposes; Chemical and Electro-Chemical Tests*; British Standards Institution: London, UK, 1990.
46. Prasetsan, S. *Preliminary Study on Brick Making Industry in ASEAN Countries; Final Report*; NRCT: Bangkok, Thailand, 1995.
47. Spinosa, L.; Vesilind, P.A. Sludge into Biosolids. In *Characterisation*; Kopp, J., Dichtl, N., Eds.; IWA Publishing: London, UK, 2001; pp. 19–38.
48. AS/NZS 4455.1. *Masonry Units, Pavers, Flags and Segmental Retaining Wall Units*; Part 1: Masonry Units; Standards Australia/Standards New Zealand: Sydney, Australia, 2008.
49. AS/NZS 4456. *Masonry Units, Segmental Pavers and Flags—Methods of Test*; General Introduction and List of Methods; Standards Australia/Standards New Zealand: Sydney, Australia, 2003.
50. AS/NZS 4456.6. *Masonry Units, Segmental Pavers and Flags*; Method 6: Determining Potential to Effloresce; Standards Australia/Standards New Zealand: Sydney, Australia, 2003.
51. Dutré, V.; Vandecasteele, C. Solidification/stabilisation of hazardous arsenic containing waste from a copper refining process. *J. Hazard. Mater.* **1995**, *40*, 55–68. [[CrossRef](#)]
52. Domínguez, E.A.; Ullman, R. ‘Ecological bricks’ made with clays and steel dust pollutants. *Appl. Clay Sci.* **1996**, *11*, 237–249. [[CrossRef](#)]
53. Kadir, A.A.; Mohajerani, A. Recycling cigarette butts in lightweight fired clay bricks. *Proc. Inst. Civ. Eng. Constr. Mater.* **2011**, *164*, 219–229. [[CrossRef](#)]
54. Quijorna, N.; Coz, A.; Andres, A.; Cheeseman, C. Recycling of Waelz slag and waste foundry sand in red clay bricks. *Resour. Conserv. Recycl.* **2012**, *65*, 1–10. [[CrossRef](#)]
55. Zhou, J.; Li, T.; Zhang, Q.; Wang, Y.; Shu, Z. Direct-utilization of sewage sludge to prepare split tiles. *Ceram. Int.* **2013**, *39*, 9179–9186. [[CrossRef](#)]
56. AS 1289.3.5.1. *Methods of Testing Soils for Engineering Purposes; Determination of the Soil Particle Density of a Soil-Standard Method*; Standards Australia International Ltd.: Sydney, Australia, 2006.
57. Ukwatta Pitiye, A.; Mohajerani, A. Effect of Organic Content in Biosolids on the Properties of Fired-Clay Bricks Incorporated with Biosolids. *J. Mater. Civ. Eng.* **2017**, *29*, 1–11. [[CrossRef](#)]
58. Mezenchevova, A.; Yeboah, N.N.; Burns, S.E.; Kahn, L.F.; Kurtis, K.E. Utilization of Savannah Harbor river sediment as the primary raw material in production of fired brick. *J. Environ. Manag.* **2012**, *113*, 128–136. [[CrossRef](#)] [[PubMed](#)]
59. Shih, P.-H.; Wu, Z.-Z.; Chiang, H.-L. Characteristics of bricks made from waste steel slag. *Waste Manag.* **2004**, *24*, 1043–1047. [[CrossRef](#)] [[PubMed](#)]
60. Hendry, A.W.; Sinha, B.P.; Davies, S.R. *Design of Masonry Structures*; Taylor Francis: London, UK, 2004.
61. Andrés, A.; Díaz, M.C.; Coz, A.; Abellán, M.J.; Viguri, J.R. Physico-chemical characterisation of bricks all through the manufacture process in relation to efflorescence salts. *J. Eur. Ceram. Soc.* **2009**, *29*, 1869–1877. [[CrossRef](#)]
62. ASTM C62. *Standard Specification for Building Brick (Solid Masonry Units Made from Clay or Shale)*; ASTM International: West Conshohocken, PA, USA, 2013.
63. Ukwatta Pitiye, A.; Mohajerani, A. Characterisation of fired-clay bricks incorporating biosolids and the effect of heating rate on properties of bricks. *Constr. Build. Mater.* **2017**, *142*, 11–22. [[CrossRef](#)]
64. USEPA. National Primary Drinking Water Regulations. United States Environmental Protection Agency, 2017. Available online: <https://www.epa.gov/ground-water-and-drinking-water/national-primary-drinking-water-regulations#one> (accessed on 17 July 2017).
65. Australian Government. Australian Drinking Water Guidelines. National Health and Medical Research Council, 2011. Available online: https://www.nhmrc.gov.au/_files_nhmrc/file/publications/nhmrc_adwg_6_version_3.3_2.pdf (accessed on 17 July 2017).
66. Industrial Waste Resource Guidelines (IWRG 631). *Solid Industrial Waste Hazard Categorization and Management*; Environment Protection Authority: Carlton, Australia, 2009.
67. *Code of Federal Regulations 261.24—Toxicity Characteristics*; US Government Printing Office: Washington, DC, USA, 2012.
68. Mohajerani, A.; Vajna, J.; Ellcock, R. Chromated copper arsenate timber: A review of products, leachate studies and recycling. *J. Clean. Prod.* **2018**, *179*, 292–307. [[CrossRef](#)]

69. Garrabrants, A.C.; Kosson, D.S.; Delapp, R.; Van der Sloot, H.A. Effect of coal combustion fly ash use in concrete on the mass transport release of constituents of potential concern. *Chemosphere* **2014**, *103*, 131–139. [[CrossRef](#)]
70. Kosson, D.S.; Garrabrants, A.C.; Delapp, R.; Van der Sloot, H.A. pH-dependent leaching of constituents of potential concern from concrete materials containing coal combustion fly ash. *Chemosphere* **2014**, *103*, 140–147. [[CrossRef](#)] [[PubMed](#)]
71. USEPA. *Method 1315—Mass Transfer Rates of Constituents in Monolithic or Compacted Granular Materials Using a Semi-Dynamic Tank Leaching Procedure*; U.S. Environmental Protection Agency: Washington, DC, USA, 2013.
72. Kosson, D.S.; Van der Sloot, H.A.; Sanchez, F.; Garrabrants, A.C. An Integrated Framework for Evaluating Leaching in Waste Management and Utilization of Secondary Materials. *Environ. Eng. Sci.* **2002**, *19*, 159–204. [[CrossRef](#)]
73. USEPA. *Method 1314—Liquid-Solid Partitioning as a Function of Liquid-Solid Ratio for Constituents in Solid Materials Using an Up-Flow Percolation Column Procedure*; U.S. Environmental Protection Agency: Washington, DC, USA, 2013.
74. Ukwatta, A.; Mohajerani, A.; Eshtiaghi, N.; Setunge, S. Variation in physical and mechanical properties of fired-clay bricks incorporating ETP biosolids. *J. Clean. Prod.* **2016**, *119*, 76–85. [[CrossRef](#)]
75. Ukwatta Pitiye, A.; Mohajerani, A.; Setunge, S.; Eshtiaghi, N. A study of gas emissions during the firing process from bricks incorporating biosolids. *J. Waste Manag.* **2018**, *74*, 413–426. [[CrossRef](#)] [[PubMed](#)]
76. Ukwatta, A.; Mohajerani, A. Leachate analysis of green and fired-clay bricks incorporated with biosolids. *J. Waste Manag.* **2017**, *66*, 134–144. [[CrossRef](#)] [[PubMed](#)]
77. Abdul Kadir, A.; Mohajerani, A. Physico-mechanical properties and leachate analysis and thermal performance of clay fired bricks incorporated with cigarette butts. In *Environmental Management and Technologies Towards Sustainable Development*; Ahmad, A.L., Lee, K.T., Eds.; Universiti Sans Malaysia: Penang, Malaysia, 2008; pp. 1–9.



© 2019 by the authors. Licensee MDPI, Basel, Switzerland. This article is an open access article distributed under the terms and conditions of the Creative Commons Attribution (CC BY) license (<http://creativecommons.org/licenses/by/4.0/>).



**Valley Sanitary District
Operations Committee Meeting
August 2, 2022**

TO: Operations Committee

FROM: Anna Bell & Ivan Monroy, Environmental Compliance Services

SUBJECT: **Request Feedback and Direction Regarding the Update to Guidance Documents Sewer Use Ordinance (SUO), Enforcement Response Plan (ERP), and Local Limits.**

Executive Summary

The purpose of this report is to provide a project update and information regarding the update of the guidance documents for the Environmental Compliance project.

Strategic Plan Compliance

This item complies with VSD Strategic Plan Objective 6.7: Maintain compliance with all regulatory, legislative, and permit requirements.

Fiscal Impact

No Fiscal Impact.

Background

The Regional Water Quality Control Board (RWQCB) requires updates of the District's guidance documents to maintain an informal pretreatment program. The updates should occur at least every 10 years to remain current with changes in permit requirements, regulatory changes, and industry best practices.

The following documents have been identified as needing to be updated.

- Sewer Use Ordinance
- Enforcement Response Plan
- Local Limits

The Sewer Use Ordinance (SUO) provides the District with legal authority to implement an industrial pretreatment program through inspections, monitoring, permitting, prohibiting specific discharges, and enforcement.

The Enforcement Response Plan (ERP) provides a framework for response to industrial user violations. The guidelines for the ERP are codified in the U.S. Code of Federal Regulations (40 CFR Part 403).

The District establishes local limits for the discharge of wastewater if its NPDES permit sets a more stringent limit than the state or federal limits of a specific pollutant.

To assist with updating these documents, the District hired EOA, Inc., the consultant that assisted the District with the 2020 NPDES permit renewal, to review the sewer use ordinance for compliance. The District worked together with EOA, Inc. to make the recommended non-substantial modification updates.

The proposed updates are based on past pretreatment compliance inspections and/or audits by United States Environmental Protection Agency (EPA) and the new National Pollutant Discharge Elimination System (NPDES) permit requirements from the 2020 permit update.

The draft document was sent to legal counsel for review and approval and incorporates their recommendations.

Recommendation

Staff recommends that the Operations Committee provide feedback and direction before this item is presented to the full Board of Directors.

Attachments

- Attachment A: EOA Update of Guidance Documents Presentation
- Attachment B: Sewer Use Ordinance (SUO)
- Attachment C: Enforcement Response Plan (ERP)
- Attachment D: Local Limits



Environmental Compliance

Update to Guidance Documents

EOA CONSULTING

VSD ENVIRONMENTAL
COMPLIANCE DEPT.

Agenda

Background

Local Limits

Sewer Use Ordinance

Enforcement Response Plan

Conclusion

Questions

Background

- Regional Water Quality Control Board (RWQCB) July 2011 Letter requiring updates to maintain an informal Pretreatment Program
- Pretreatment Program documents requiring updates
 - Sewer Use Ordinance (provides legal authority to implement Pretreatment Program through inspections, monitoring, permitting, enforcement and prohibiting specific discharges)
 - Local Limits (discharge limits for pollutants)
 - Enforcement Response Plan (guidance for taking consistent enforcement actions)
- Updates based on:
 - Past Pretreatment Compliance Inspections or Audits
 - New National Pollutant Discharge Elimination System (NPDES) Permit requirements

Local Limits

- Conducted according to the United States Environmental Protection Agency (EPA's) July 2004 Local Limits Development Guidance Document
- Data Compilation and Review
 - Influent & Effluent Data from 2018 to 2021
 - Needed more information – request sampling
- Sampling Events
 - January to February 2022
- Identify Pollutants of Concern (POC)
 - 15 POCs identified as EPA's "National" constituents
- Compare Maximum Allowable Headworks Loading (MAHLs) and loadings
- Current limits are sufficiently protective

Sewer Use Ordinance (SUO)

- Establishes uniform requirements for direct and indirect contributors to wastewater collection and treatment for VSD
- Consistent with applicable State and Federal laws
 - Clean Water Act (33 US Code 1251 et seq)
 - General Pretreatment Regulations (40 CFR, Part 403)
- Review and Update
 - Remove conflicting language
 - Include Model EPA Ordinance language
 - Consistent with current VSD practices
 - Include past Pretreatment Compliance Inspection / Pretreatment Compliance Audit (PCI/PCA) recommendations
 - Remove Transportable Treatment Unit Discharge Permit, not in use and include Hauled Wastewater conditions

Enforcement Response Plan (ERP)

- Guidance document for enforcement procedures pertaining to Industrial Pretreatment Program
- Based upon enforcement provisions in Sewer Use Ordinance (SUO)
 - Defines enforcement actions based on the nature/severity of the violation
 - Promotes consistent use of enforcement remedies
 - Eliminates uncertainty and confusion
 - Establishes escalating response for violations
- Review and Update Enforcement Response Plan (ERP) language
 - Remove conflicting language
 - Update using Plain Language Policy guidance
 - Consistent with 40 CFR 403 regulations and past PCI/PCA recommendations
 - Reflect on current VSD practices

Conclusion

- It's important to update these documents to comply with audit recommendations and to be consistent with applicable State and Federal laws
- Operations Committee Meeting
- Public Comments
- Board of Directors
- RWQCB (40 CFR 403.18 POTW shall submit to the Approval Authority any non-substantial modifications at least 45 days prior to implementation.)



Questions

**VALLEY SANITARY DISTRICT
SEWER CONSTRUCTION AND USE ORDINANCE**



VSD

**ORDINANCE NO. 2022-###
Adopted: , 2022**

**VALLEY SANITARY DISTRICT
SEWER CONSTRUCTION AND USE ORDINANCE**

TABLE OF CONTENTS

VALLEY SANITARY DISTRICT
SEWER CONSTRUCTION AND USE ORDINANCE

INTRODUCTION AND SUMMARY

Valley Sanitary District was formed in 1925 and now provides for collection, treatment and disposal of wastewater generated by the City of Indio, a portion of the City of Coachella, some unincorporated areas of Indio and the adjacent Cabazon Band of Mission Indians. Recognizing the need to control the quantity and quality of wastewaters discharged to the sewerage facilities and establish standards for public sewers, the District's Board of Directors adopted ordinances regulating the construction and use of the sewerage systems. This Ordinance sets forth uniform requirements for Users of the District's sewerage facilities and enables the District to comply with all applicable state and Federal laws including the Clean Water Act (33 U.S.C. 1251, et. seq.), and many of the requirements of the General Pretreatment Regulations (40 CFR 403). The objectives of this Ordinance are:

- To ensure that sewerage facilities connected to, and a part of the District's sewerage system provide for the maximum public benefit by meeting the District's standards.
- To ensure the District's compliance with the requirements of Federal, state, and local regulatory agencies and the National Pollutant Discharge Elimination System (NPDES).
- To prevent the introduction of pollutants into the District's sewerage facilities that may interfere with District operations, including but not limited to blockages caused by solids or fats, oils, and grease (FOG) or pollutants that contaminate the resulting sludge.
- To prevent the introduction of pollutants into the District's sewerage facilities that may pass through the District's sewerage facilities, inadequately treated, into receiving waters or otherwise be incompatible with the sewerage facilities.
- To ensure that the quality of the biosolids generated during treatment is maintained at a level that allows their use and disposal in compliance with applicable statutes and regulations.
- To improve the opportunity to recycle, reuse, and conserve non-renewable resources.
- To require waste minimization and material substitution by Industrial Users.
- To prevent exposure of the District's employees to chemical hazards created by industrial discharges.
- To establish an effective permitting, monitoring, and enforcement program for the control of industrial wastewaters.
- To equitably allocate treatment costs.

This Ordinance shall apply to all Users of the District's sewerage facilities. The Ordinance authorizes the issuance of Wastewater Connection Permits and Wastewater Discharge Permits; authorizes monitoring, compliance, and enforcement activities; establishes administrative review procedures; requires Industrial User reporting; and provides for the setting of fees for the equitable distribution of costs resulting from the program established herein.

Discharge to the sewer is a privilege and not a right. The privilege to discharge is controlled by this Ordinance. Individual control of a discharge is through the issuance of a permit. Issuance of a permit must be followed by enforcement of its provisions. Therefore, if a permit is issued, then the District is committed to make sure that the User follows the permit conditions or after working with the User to

come into compliance, revoking the privilege and disconnecting sewer services.

Users of the District's sewerage facilities include a wide range of commercial and industrial facilities. While all Users are subject to the regulations contained herein and required to have a connection permit, only a few types of facilities require discharge permits. Of the five types of permits, two will be the most common. Class I Permittees are those whose discharge is likely to have an adverse effect on the District's sewerage system if not properly controlled. These dischargers may be federally regulated industries such as metal finishers, a discharge greater than 25,000 gallons per day such as a bottling plant, or they may discharge a regulated constituent in a quantity that may cause a problem in the District's collection or treatment facilities such as a grease recycling facility. Among other conditions, the permit may require the user to meet certain discharge limits and perform monitoring of its own discharge to establish that it is in compliance with applicable discharge limits.

Other commercial or industrial facilities such as food service establishments, radiator shops, and laundromats may be required to obtain a General Discharge Permit or a Class II discharge permit. These types of facilities will only be required to obtain a permit if the District suspects or knows that the discharge from a certain class of business is adversely affecting the District's sewerage facility. For example, if grease from food service establishments is causing a problem in the collection or treatment system, the District may decide to require all food service establishments to obtain permits. The permit may require proof of a properly sized and periodic maintenance of the grease interceptor. If the problem is not mitigated, the District may require discharge testing to prove compliance with a discharge limit.

Enforcement of the Ordinance is designed to allow those industries willing to comply to do so with an understanding from the District. Normally, if the User is cooperative, the District will work with the User to bring it into compliance with permit conditions taking the User through a series of stepped-up enforcement. However, the Ordinance is also flexible so that when extreme or hazardous conditions exist, the District can immediately stop the discharge from causing damage to the District's facilities.

**AN ORDINANCE OF THE BOARD OF DIRECTORS OF
VALLEY SANITARY DISTRICT
ESTABLISHING WASTEWATER DISCHARGE
REGULATIONS ORDINANCE # 2022-###**

The Board of Directors of Valley Sanitary District, California do hereby ORDAIN:

Section I: Wastewater Discharge Regulations governing the use of District sewerage facilities are hereby enacted to provide:

**ARTICLE 1
GENERAL PROVISIONS**

101. AUTHORIZATION

This Ordinance is enacted pursuant to authority contained in the Sanitary District Act of 1923, California Health and Safety Code, Sections 6400 et seq. and exercises authority conferred by law including, but not limited to, Health and Safety Code Sections 5400 through 5474, and California Government Code, Sections 54725 through 54740.6

102. PURPOSE AND POLICY

- A. The purpose of this Ordinance is to provide for the maximum public benefit from the use of District's facilities. This shall be accomplished by regulating sewer use and wastewater discharges, by providing equitable distribution of costs in compliance with applicable Federal, State, and local Regulations, and by providing procedures that will allow the District to comply with requirements placed upon the District by other regulatory agencies.
- B. This Ordinance shall be interpreted in accordance with the definitions set forth in Section 103. The provisions of the Ordinance shall apply to the direct or indirect discharge of all liquid wastes carried to facilities of the District.
- C. To comply with Federal, State, and local policies and to allow the District to meet applicable standards of treatment plant effluent quality, biosolids quality, and air quality, provisions are made in this Ordinance for the regulation of wastewater discharges to the public sewer. This Ordinance establishes quantity and quality limits on all wastewater discharges that may adversely affect the District's sewerage systems, processes, effluent quality, biosolids quality, air emission characteristics, or inhibit the District's ability to beneficially reuse or dispose of its biosolids or meet biosolids discharge criteria. It is the intent of these limits to improve the quality of wastewater being received for treatment and to encourage water conservation and waste minimization by all users connected to a public sewer. It is the District's intent to limit future increases in the quantity (mass emission) of waste constituents being discharged. This Ordinance also provides for regulation of the degree of waste pretreatment required, the issuance of permits for wastewater discharge and connections and other miscellaneous permits and establishes penalties for violation of the Ordinance.
- D. Since the District is committed to a policy of wastewater reclamation and reuse as an alternate source of water supply, the implementation of programs for reclamation through wastewater treatment processes may necessitate more stringent quality

requirements on wastewater discharges. In the event that more stringent quality requirements are necessary, the applicable Ordinance will be amended to reflect those changes.

- E. Since the District is committed to a policy for the beneficial use of biosolids, the implementation of programs to land-apply or provide for the marketing and distribution of biosolids may necessitate more stringent quality requirements on wastewater discharges.
- F. Since the District is also committed to meet applicable air quality goals established by the South Coast Air Quality Management District, more stringent quality requirements on wastewater discharges may be required to meet such goals.

103. DEFINITIONS

- A. Unless otherwise defined herein, the testing procedures for waste constituents and characteristics shall be as provided in 40 CFR Part 136 (Code of Federal Regulations; Title 40; Protection of Environment; Chapter I, Environmental Protection Agency; Part 136, Test Procedures for the Analyses of Pollutants), or as specified.

Other terms not herein defined are defined as being the same as set forth in the current editions of the California Building Code and California Plumbing Code.

- 1. Applicant shall mean the person making application for a connection permit for a sewer or plumbing installation and shall be the owner, or authorized agent of premises to be served by the sewer for which a permit is requested.
- 2. Authorized or Duly Authorized Representative of the User:
 - a) If the User is a corporation:
 - 1) The president, secretary, treasurer, or a vice-president of the corporation in charge of a principal business function, or any other person who performs similar policy or decision-making functions for the corporation; or
 - 2) The manager of one or more manufacturing, production, or operating facilities, provided the manager is authorized to make management decisions that govern the operation of the regulated facility including having the explicit or implicit duty of making major capital investment recommendations, and initiate and direct other comprehensive measures to ensure long-term environmental compliance with environmental laws and regulations; can ensure that the necessary systems are established or actions taken to gather complete and accurate information for individual wastewater discharge permit or general discharge permit requirements; and where authority to sign documents has been assigned or delegated to the manager in accordance with corporate procedures.
 - b) If the User is a partnership or sole proprietorship: a general partner or proprietor, respectively.
 - c) If the User is a Federal, State, or local governmental facility: a director or

highest official appointed or designated to oversee the operation and performance of the activities of the government facility, or their designee.

- d) The individuals described in paragraphs 1 through 3 above may designate a Duly Authorized Representative if the authorization is in writing, the authorization specifies the individual or position responsible for the overall operation of the facility from which the discharge originates or having overall responsibility for environmental matters for the company, and the written authorization is submitted to the District.
3. Best Management Practices (BMPs) shall mean the schedule of activities, prohibition of practices, maintenance procedures, and other management practices to implement the prohibitions listed in 40 CFR 403.5 (a)(1) and (b). BMPs also include treatment requirements, operating procedures, and practices to control site runoff, spillage or leaks, sludge or waste disposal, or drainage of raw materials storage.
 4. Biochemical Oxygen Demand (BOD) shall mean the quantity of oxygen utilized in the biochemical oxidation of organic matter under standard laboratory procedures for five (5) days at 20 degrees centigrade, usually expressed as a concentration (e.g., mg/l)..
 5. Biosolids shall mean a primarily organic solid product, produced by wastewater treatment process that can be beneficially recycled.
 6. Board shall mean the Board of Directors of Valley Sanitary District.
 7. Building shall mean any structure used for human habitation or a place of business, recreation or other purpose.
 8. Building Drain shall mean the part of the lowest piping of a drainage system that receives the discharge of sanitary waste from drainage pipe inside the walls of the building and conveys it to the private sewer lateral beginning two feet outside the building wall.
 9. Building Sewer See Private Sewer Lateral.
 10. Bypass shall mean the intentional diversion of wastestreams from any portion of an industrial user's treatment facility.
 11. Categorical Pretreatment Standards or Categorical Standard shall mean any regulation containing pollutant discharge limits promulgated by the U.S. EPA in accordance with Sections 307(b) and (c) of the Clean Water Act (33 U.S.C. 1317) that apply to a specific category of industrial users and appear in 40 CFR Chapter I, Subchapter N, Parts 405-471.
 12. Chemical Oxygen Demand (COD) shall mean the measure of chemically oxidizable material in domestic or other wastewaters as determined by appropriate testing procedure and expressed in terms of milligrams per liter.
 13. City shall mean the cities of Indio or Coachella, California, as served by the District.
 - 14.

15. Code of Federal Regulations (CFR) shall mean the codification of the general and permanent regulations published in the Federal Register by the executive departments and agencies of the Federal Government.
16. Composite Sample shall mean a collection of individual samples obtained at selected intervals based on an increment of either flow or time. The resulting mixture (composite sample) forms a representative sample of the wastestream discharged during the sample period. Samples will be collected when manufacturing, processing, or other industrial wastewater discharge occurs.
17. Connection Permit shall mean a permit issued by the District, upon payment of a capital facilities connection charge, authorizing the Permittee to connect directly to a District sewerage facility or to a sewer that ultimately discharges into a District sewerage facility.
18. Contractor shall mean an individual, firm, corporation, partnership, or association duly licensed by the State of California to perform the type of work to be done under the connection permit.
19. County shall mean County of Riverside, California, and the unincorporated areas of Riverside County within the District's service boundary.
20. Development shall mean parcel of land on which dwelling units, commercial or industrial buildings or other improvements are built.
21. Discharge or Indirect Discharge shall mean the introduction of pollutants into the District's facilities from any non-domestic source.
22. Discharger shall mean any person who discharges or causes a discharge of non-domestic wastewater directly or indirectly to a public sewer. Discharger shall mean the same as User.
23. District Sewerage Facility or System shall mean any property belonging to the District used in the treatment, reclamation, reuse, transportation, or disposal of wastewater, or biosolids.
24. District shall mean Valley Sanitary District.
25. Domestic Wastewater shall mean the liquid and solid waterborne wastes derived from the ordinary living processes of humans of such character as to permit satisfactory disposal, without special treatment, into the public sewer or by means of a private disposal system.
26. Dwelling Unit shall mean a single unit providing complete, independent living facilities for one or more persons, which may include permanent provisions for living, sleeping, eating, cooking and sanitation. For the purpose of this Ordinance, a mobile home shall be considered as a Dwelling Unit. More than one Dwelling Unit per structure and/or lot shall be deemed Multiple Dwelling Units.
27. Enforcement Compliance Schedule Agreement (ECSA) shall mean a mutual agreement between the District and Permittee amending the permit to require implementation of necessary pollution prevention or pretreatment practices and/or installation of equipment to ensure permit compliance.

28. Fats, Oils, and Grease (FOG) shall mean organic polar compound derived from animal and/or plant sources that contain multiple carbon chain triglyceride molecules. These substances are detectable and measurable using analytical test procedures established in 40 CFR 136, as may be amended.
- 29.
30. Federal Regulations shall mean any applicable provision of the Federal Water Pollution Control Act, also known as the Clean Water Act, as amended, Title 33, United States Code, Section 1251 and following, and any regulation promulgated by the US EPA under Title 40 CFR implementing that act.
31. Floor Area shall mean the area included within the surrounding exterior walls of a building or portion thereof, exclusive of ramps, docks, vent shafts, and courts. The floor area of a building, or portion thereof, not provided with surrounding exterior walls shall be the usable area under the horizontal projection of the roof or floor above.
32. Flow Monitoring Facilities shall mean equipment and structures provided at the user's expense to measure, totalize, and/or record, the incoming water to the facility or the wastewater discharged to the sewer.
33. Food Service Establishment (FSE) includes, but is not limited to, any facility preparing and/or serving food for commercial use or sale. This includes restaurants, cafes, lunch counters, cafeterias, hotels, hospitals, convalescent homes, factory or school kitchens, catering kitchens, bakeries, grocery stores with food preparation, meat cutting and preparation, and other food handling facilities not listed above where fats, oils, and grease may be introduced into the sanitary sewers.
34. General Manager shall mean the General Manager of Valley Sanitary District, or the authorized representative of the General Manager of Valley Sanitary District.
35. Grab Sample shall mean a sample taken from a waste stream on a one-time basis without regard to the flow in the waste stream and without consideration of time.
36. Illicit Connection shall mean any man-made conveyance or drainage system, pipeline, conduit, inlet, or outlet through which the discharge of any Pollutant, Waste, Wastewater, or other material to the Public Sewer occurs or may occur, either directly or indirectly, other than discharges that comply with the requirements of this Ordinance.
37. Industrial User shall mean any user that discharges non-domestic wastewater.
38. Industrial Wastewater shall mean all liquid-carried wastes and wastewater of the community, excluding domestic wastewater, and shall include all wastewater from any producing, manufacturing, processing, agricultural, or other operation. These may also include wastes of human origin similar to domestic wastewaters.
39. Infectious Waste shall mean materials which are likely to transmit etiologic agents that cause, or significantly contribute to the cause of, increased morbidity or mortality of human beings, as more specifically set forth in Health

and Safety Code Section 25117.5.

40. Inspector shall mean any person authorized by the General Manager to inspect any existing or proposed wastewater generation, conveyance, processing, and disposal facilities.
41. Interference shall mean any discharge which, alone or in conjunction with discharges from other sources, inhibits or disrupts the District's treatment processes or operations, or its biosolids processes, use, or disposal; or is a cause of violation of the District's NPDES permit or prevents lawful biosolids use or disposal.
42. Intercepting Sewer shall mean a large sewer or conduit which receives the discharges from many smaller tributary sewers. Sometimes referred to as a trunk sewer.
43. Lateral Sewer see Private Sewer Lateral.)
44. LEL (Lower Explosive Limit) shall mean the minimum concentration of combustible gas or vapor in air (usually expressed in percent by volume at sea level) that will ignite if an ignition source (sufficient ignition energy) is present.
45. Medical Waste shall mean isolated wastes, infectious agents, human blood and blood products, pathological wastes, sharps, body parts, formites, etiologic agents, contaminated bedding, surgical wastes, potentially contaminated laboratory wastes, dialysis wastes, hypodermic needles, syringes, instruments, utensils or any other paper or plastic items of disposable nature used for medically related purposes. The term "Medical Waste" shall exclude de minimus amounts of wastes, human blood and paper items of a disposable nature associated with domestic wastewater discharges.
46. Multiple Dwelling shall mean a building for residential purposes having facilities for the occupancy of more than one person or family, including, but not limited to, the following: hotels, motels, auto courts, trailer courts, apartment houses, duplex, rooming house, boarding house and dormitories.
47. National Pretreatment Standard shall mean any regulation containing pollutant discharge limits promulgated by the EPA in accordance with section 307 (b) and (c) of the Clean Water Act, which applies to Industrial Users. This term includes prohibitive discharge limits established pursuant to 40 CFR 403.5.
48. New Construction shall mean any structure planned or under construction for which a connection permit has not been issued.
49. New Source shall mean those sources that are new as defined by 40 CFR 403.3(m) as revised.
- 50.
51. Oil and Grease shall mean hexane extractable material that is polar and non-polar organic substances of animal, vegetable, and mineral nature. These substances are detectable and measurable using analytical test procedures established in 40 CFR Part 136, as may be amended
52. Pass Through shall mean discharge through the District's sewerage facilities to

waters of the state or U.S. which, alone or in conjunction with discharges from other sources, is a cause of a violation of the District' NPDES permit or other e discharge requirements applicable to the District.

53. Permittee shall mean a person who has received a permit to discharge wastewater into the District's sewerage facilities subject to the requirements and conditions established by the District.
54. Person shall mean any human being, individual, firm, company, partnership, association, private corporations, and governmental entities.
55. pH shall mean a measure of the acidity or alkalinity of a solution, expressed in standard units.
56. Pollutant shall mean dredged spoil, solid waste, incinerator residue, filter backwash, sewage, garbage, sewage sludge, munitions, Medical Wastes, chemical wastes, biological materials, radioactive materials, heat, wrecked or discarded equipment, rock, sand, cellar dirt, municipal, agricultural and industrial wastes, and certain characteristics of wastewater (e.g., pH, temperature, TSS, turbidity, color, BOD, COD, toxicity, or odor).
57. Program Manager shall mean that person duly designated by the General Manager to implement the District's Pretreatment Program and perform the  as specified in this Ordinance.
58. Pretreatment shall mean the reduction of the amount of pollutants, the elimination of pollutants, or the alteration of the nature of pollutant properties in wastewater to a level authorized by the District prior to discharge of the wastewater into the District's sewerage system. The reduction or alteration can be obtained by physical, chemical or biological processes or process changes by other means, except as prohibited by 40 CFR 403.6(d).
59. Pretreatment Requirement shall mean any substantive or procedural pretreatment requirement, other than a Pretreatment Standard, imposed on an Industrial User.
60. Pretreatment Standard shall mean any regulation containing pollutant discharge limits or prohibitions promulgated by EPA, the State of California or the District, including but not limited to promulgated categorical standards; national prohibited discharge standards; general discharge prohibitions; and any specific local discharge limits established by the District.
61. Private Disposal System shall mean a septic tank with the effluent discharging into a subsurface disposal field or into one or more seepage pits.
62. Private Sewer Line shall mean a sewer that receives discharge from more than one building drain and extends to and includes the connection to the public sewer main.
63. Private Sewer Lateral (aka Lateral Sewer or Building Sewer) shall mean the portion of sewer system, beginning at the building drain, and extending to and including the connection to the public sewer. This includes a sewer that receives discharge from more than one building drain and extends to and includes the connection to the public sewer main, which may also be referred to as a Private Sewer Line.

64. Public Sewer shall mean a sewer owned and maintained by the District. Public sewer includes a factory formed stub that is an integral part of the public sewer mainline, but expressly does not include any portion of a building sewer, private sewer lateral or private sewer line which may lie within any public street or right of way.
65. Publicly Owned Treatment Works (POTW) shall mean Valley Sanitary District's Wastewater Treatment Plant and any other devices or systems used by the District in the collection, storage, conveyance (including all sewers, pipes, lift stations, and other conveyances which convey wastewater to the wastewater treatment plant), treatment, recycling, and reclamation of municipal sewage.
66. RCRA shall mean Resource Conservation and Recovery Act of 1976 (42 U.S.C. 6901, et seq.) and as amended.
67. Regulatory Agencies shall mean those agencies having jurisdiction over the operation of the District including, but not limited to, the following:
- a) United States Environmental Protection Agency, Region IX, San Francisco and Washington, DC (EPA).
 - b) California State Water Resources Control Board (SWRCB).
 - c) California Regional Water Quality Control Board, Colorado River Basin Region (RWQCB).
 - d) South Coast Air Quality Management District (SCAQMD).
 - e) California Department of Health Services (DOHS).
68. Sample Point shall mean a location approved by the District, from which wastewater can be collected that is representative in content and consistency of the entire flow of wastewater being discharged.
69. Sampling Facilities shall mean structure(s) or equipment provided at the user's expense for the District or user to measure and record wastewater constituent mass, concentrations, collect a representative sample, or provide access to plug or terminate the discharge.
70. Sanitary Waste shall mean domestic wastewater, human excrement, and gray water (household showers, dish washing operations, etc.).
71. Septic Waste shall mean any sewerage from holding tanks such as chemical toilets, and septic tanks.
72. Sewage shall mean liquid and water carried wastes of the community from residences, business buildings, institutions and industrial establishments or permitted into a public sewer.
73. Sewer shall mean a conduit that carries sewage and to which storm, surface and ground waters are not intentionally admitted, which is intended to flow to the District's treatment works.
74. Significant Industrial User shall mean

- A. an Industrial User subject to categorical Pretreatment Standards, or
- B. an Industrial User that
 - a. discharges 25,000 gallons per day or more of process wastewater to the sewer (excluding sanitary, non-contact cooling, and boiler blowdown) ;
 - b. contributes a process wastestream that makes up five percent or more of the District's dry weather hydraulic loading or organic capacity at the POTW; or
 - c. is designated as such by the Control Authority on the basis that the Industrial User has a reasonable potential for adversely affecting the POTW's operation or for violating any Pretreatment Standard or requirement (in accordance with 40 CFR 403.8(f)(6)).

75. Significant Non-compliance (SNC) shall mean a violation by any Significant Industrial User which meets one or more of the following criteria or any Industrial User which meets criteria in (iii), (iv), or (vii):

Violations of wastewater discharge limits:

- i. Chronic Violations. Sixty-six percent or more of all the measurements taken for the same pollutant parameter during a six-month period exceed (by any magnitude) a numeric limit, requirement, instantaneous limit, or Pretreatment Standard, as defined by 40 CFR 403.3(l);
- ii. Technical Review Criteria (TRC) Violations. Thirty-three percent or more of all the measurements for the same pollutant parameters during a six-month period exceed a numeric limit, requirement, instantaneous limit or Pretreatment Standard as defined by 40 CFR 403.3(l) multiplied by the applicable TRC (TRC=1.4 for BOD, TSS, oil, and grease, and 1.2 for all other pollutants except pH);
- iii. Any other violation of a standard, requirement or Pretreatment Standard as defined by 40 CFR 403.3(l) (daily maximum or long-term average, instantaneous limit, or narrative standard) that caused, alone or in combination with other discharges, interference or pass through (including endangering the health of the POTW personnel or the public).
- iv. Any discharge of a pollutant that has caused imminent endangerment to human health or welfare or to the environment or has resulted in the POTW's exercise of its emergency authority to halt or prevent such a discharge.
- v. Failure to meet, within ninety days after the schedule date, a compliance milestone contained in a local control mechanism or enforcement order for starting construction, completing construction, achieving final compliance.
- vi. Failure to provide, within 45 days after the due date,

required reports such as baseline monitoring reports, 90-day compliance reports, periodic self-monitoring reports, and reports on compliance with compliance schedules.

- vii. Failure to accurately report non-compliance.
 - vii. Any other violation or group of violations, which may include a violation of Best Management Practices, which the General Manager determines will adversely affect the wastewater operation or implementation of the Pretreatment Program.
76. Single Family Dwelling shall mean a single house that provides complete, independent living facilities for one single family, which may include permanent provisions for living, sleeping, eating, cooking and sanitation. For the purpose of this Ordinance, recreational vehicle or park model shall not be considered as a single-family dwelling.
77. Slug Load or Slug Discharge shall mean any discharge at a flow rate or concentration, which could cause a violation of the prohibited discharge standards of this ordinance. A Slug Discharge is any discharge of a non-routine, episodic nature, including but not limited to an accidental spill or a non-customary batch discharge, which has a reasonable potential to cause Interference or Pass Through, or in any other way violate the POTW's regulations, Local Limits or Permit conditions..
78. Solid Wastes shall mean the non-liquid carried wastes normally considered to be suitable for disposal with refuse at sanitary landfill refuse disposal sites.
79. Spent Solutions shall mean any concentrated non-domestic wastewater i.e. (Static Rinse, Plating Solutions)
80. Spill Containment shall mean a protection system installed by the Permittee to prohibit the discharge to the sewer of slug discharges.
81. Standard Industrial Classification (S.I.C.) shall mean a system of classifying industries as identified in the S.I.C. Manual, 1987, or subsequent edition, as prepared by the United States Office of Management and Budget.
82. Standard Methods shall mean procedures described in the current edition of Standard Methods for the Examination of Water and Wastewater, as published by the American Public Health Association, the American Water Works Association and Water Environment Federation.
83. Standard Specifications shall mean design and construction standards for sewerage works which conform to the District's Standard Specifications for Construction.
84. Storm Sewer or Storm Drain shall mean a sewer which carries storm and surface or ground waters and drainage, but excludes sewage and industrial wastewater
85. Street shall mean any public highway, road, avenue, alley, or similar roadway.
86. Suspended Solids shall mean the insoluble solid matter suspended in wastewater that is separable from the liquid portion of the waste by laboratory

filtration in accordance with the procedure described in Standard Methods.

87. Tributary Sewer shall mean a waste carrying conduit which empties directly or indirectly into an intercepting sewer.
88. Uncontaminated Water shall mean the same as unpolluted which is water of the community to which no pollutant has been added intentionally or accidentally. Examples include, but are not limited to, non-contact single pass cooling water, rainwater, and uncontaminated groundwater, .
89. User shall mean any person who discharges or causes a discharge of wastewater directly or indirectly to a public sewer.
90. Waste shall mean sewage and any and all other waste substances, liquid, solid, gaseous or radioactive, associated with human activity or of human or animal nature, including such wastes placed within containers of whatever nature prior to and for the purpose of disposal
91. Waste Manifest shall mean that receipt which is retained by the generator of hazardous wastes as required by the State of California or the United States Government pursuant to RCRA, or the California Hazardous Materials Act, or that receipt which is retained by the generator for recyclable wastes or liquid non- hazardous wastes as required by the District.
92. Wastewater Constituents and Characteristics shall mean the individual chemical, physical, bacteriological, and radiological parameters, including volume and flow rate and such other parameters that serve to define, classify, or measure the quality and quantity of wastewater.

- B. Words used in this Ordinance in the singular may include the plural and the plural the singular. Use of masculine shall mean feminine and use of feminine shall mean masculine. Shall is mandatory; may is permissive or discretionary.

104. CONFIDENTIAL INFORMATION

All user information and data on file with the District shall be available to the public and governmental agencies without restriction unless the user specifically requests and is able to demonstrate to the satisfaction of the District that the release of such information would divulge information, processes or methods which would be detrimental to the user's competitive position. The demonstration of the need for confidentiality made by the User must meet the burden necessary for withholding such information from the general public under applicable State and Federal Law. Any such claim must be made at the time of submittal of the information by marking the submittal "Confidential Business Information" on each page containing such information. Information which is demonstrated to be confidential shall not be transmitted to anyone other than a governmental agency without prior notification and approval of the user. Information concerning wastewater quality and quantity shall not be deemed confidential.

105. TRANSFER OF PERMITS

- A. Permits issued under this Ordinance are for a specific user, for a specific operation at a specific location or for a specific waste hauler and create no vested rights.
 1. No permit may be transferred to allow a discharge to a public sewer from a point other than the location for which the permit was originally issued.
 2. Except as expressly set forth herein, no permit for an existing facility may be

transferred to a new owner and/or operator of that facility.

- B. At least thirty (30) days prior to the sale or transfer of ownership of any business operating under a permit issued by the District, the Permittee shall notify the District in writing of the proposed sale or transfer. The successor owner shall apply to the District for a new permit at least fifteen (15) days prior to the sale or transfer of ownership in accordance with the provisions of this Ordinance. A successor owner shall not discharge any wastewater for which a permit is required by this Ordinance until a permit is issued by the District to the successor owner.
- C. Notwithstanding the foregoing, the District may, in its discretion, allow the transfer of a permit to a new owner and/or operator, at the same location for which the permit was originally issued, if:
 - 1. The existing Permittee and the proposed new owner and/or operator provide the District with written notification of the intended transfer at least thirty (30) days in advance of the transfer date; and
 - 2. The District approves, in writing, the permit transfer prior to commencement of operations by the new owner and/or operator.
- D. The written notification of intended transfer shall be in a form approved by the District and shall include a written certification by the new owner and/or operator which:
 - 1. States that the new owner or operator has no immediate intent to modify the facility's operations and/or processes;
 - 2. Identifies the specific date on which the transfer is to occur; and
 - 3. Acknowledges that the new owner or operator is fully responsible for complying with the terms and conditions of the existing permit and all provisions of this Ordinance.
- E. Except as expressly set forth in Section 105.C, any permit that is transferred to a new owner and/or operator or to a new facility is void.

106. AUTHORITY The District is regulated by several agencies of the United States Government and the State of California, pursuant to the provisions of Federal and State Law. Federal and State Laws grant the District the authority to regulate and/or prohibit, by the adoption of ordinances or resolutions, and by issuance of construction and discharge permits, the discharge of any waste, directly or indirectly, to the District's sewerage facilities. This authority includes the right to establish limits, conditions, and prohibitions; to establish flow rates or prohibit flows discharged to the District's sewerage facilities; to require the development of compliance schedules for the installation of equipment systems and use of materials by all users; and to take all actions necessary to enforce its authority, whether within or outside the District's boundaries, including those users that are tributary to the District or within areas that the District has contracted to provide sewerage services.

The District also owns, maintains, and operates collection, treatment, recycle and disposal facilities. As authorized by State law, the District regulates the connections to its facilities through ordinances and resolutions and by issuance of connection permits.

The District has the authority pursuant to California Health and Safety Codes 5471 and 5474 to prescribe, revise, and collect all fees and charge for services and facilities furnished by the District either within or without its territorial limits.

107. DELEGATION OF AUTHORITY

Whenever any power is granted to or a duty is imposed upon the General Manager, the power may be exercised or the duty may be performed by any person so authorized by the General Manager.

108. SIGNATORY REQUIREMENTS

Reports and permit applications required by this Ordinance shall contain the following certification statement:

"I certify under penalty of law that this document and all attachments were prepared under my direction or supervision in accordance with a system designed to assure that qualified personnel properly gather and evaluate the information submitted. Based on my inquiry of the person or persons who manage the system, or those persons directly responsible for gathering the information, the information submitted is, to the best of my knowledge and belief, true, accurate, and complete. I am aware that there are significant penalties for submitting false information, including the possibility of fine and imprisonment for knowing violations." The statement shall be signed by an authorized representative of the industrial user as defined in Section 103(A)(2) of this Ordinance.

109. POWERS

The General Manager or designee is authorized to:

- A. Issue Connection Permits;
- B. Issue Waste Discharge Permits;
- C. Enter into Agreements;
- D. Require the installation and maintenance of pretreatment and/or monitoring facilities and equipment;
- E. Conduct inspections of facilities, including, but not limited to, inspecting and copying records;
- F. Require monitoring and reporting of discharges to the public sewer system;
- G. Monitor the quality of wastewater entering the sewer system;
- H. Require the development of spill containment plans; slug load control plans and reporting of accidental discharges;
- I. Require the development of a Slug Control Plan (per Title 40 of the Code of Federal Regulations (40 CFR) 403.8(f) (2) (vi).
- J. Deny, approve or approve with conditions, new or increased discharges or change in the quantity or characteristics of discharges, when such discharges do not meet applicable pretreatment requirements as specified in 40 CFR 403.8(f)(1)(i);
- K. Take enforcement actions against those who violate or cause violation of this Ordinance or discharge permit conditions. These actions may include, but are not limited to the following:
 - 1. Issuing written warnings;
 - 2. Issuing Notices of Violation;
 - 3. Issuing Administrative Orders;
 - 4. Issuing Cease and Desist Orders;
 - 5. Initiating and conducting non-compliance meetings;
 - 6. Initiating and conducting administrative hearings;
 - 7. Petitioning the courts for injunctions or civil penalties;
 - 8. Signing criminal complaints;
 - 9. Terminating services;

10. Requiring payment of violation charges;
11. Revoking and/or suspending the discharge permit; and
12. Collecting the administrative and legal costs of enforcement from the violator.

110. PUBLIC PARTICIPATION

In accordance with the public participation requirements of 40 CFR part 25 in the enforcement of National Pretreatment Standards, the District shall include provision for at least annual public notification in a newspaper(s) of general circulation that provides meaningful public notice within the jurisdiction(s) served by the District of Industrial Users which, at any time during the previous 12 months, were in Significant Noncompliance with applicable Pretreatment Standards and Requirements.

ARTICLE 2

PROHIBITIONS AND LIMITS ON DISCHARGES

201. GENERAL PROHIBITIONS

- A. No person shall construct or maintain any privy, privy vault, septic tank, cesspool, seepage pit or other facility intended or used for the disposal of sewage within the jurisdiction of the District, unless approved by the Board of Directors subject to criteria as detailed in Article 3, 301D.
- B. No user shall introduce or cause to be introduced into the POTW any pollutant or wastewater which cause pass through or interference.
- C. Illicit Connections: No person shall construct or maintain an Illicit Connection to the Public Sewer.

202. SPECIFIC PROHIBITIONS

- A. No person shall discharge or cause to be introduced a quantity or quality of wastewater directly or indirectly to sewerage facilities owned by or tributary to the District's sewerage facilities which causes, or is capable of causing, either alone or by interaction with other substances:
 - 1. Pollutants which create a fire or explosion hazard in the POTW, including, but not limited to, waste streams with a closed-cup flashpoint of less than 140 degrees Fahrenheit (60 degrees Centigrade) using the test methods specified in 40 CFR part 261.21;
 - 2. Pollutants which will cause corrosion or structural damage to the POTW, but in no case with a pH lower than 5.5 or more than 11.0, or otherwise causing corrosive structural damage to the POTW or equipment;
 - 3. Solid or viscous pollutants which will cause obstruction to the flow in the sewer system resulting in interference or damage to the sewerage facilities;
 - 4. Danger to life or safety of any person;
 - 5. Impairment of the effective maintenance or operation of the sewerage system;
 - 6. Toxic gases, vapors, or fumes within the sewerage facilities in a quantity that may cause acute worker health and safety problems;
 - 7. Any pollutant, including oxygen demanding pollutants (BOD, etc.) released in a discharge at a flow rate and/or pollutant concentration which, either singly or by interaction with other pollutants, will cause Interference with the POTW;
 - 8. The District's effluent to fail a toxicity test;
 - 9. Discoloration, pass through, or any other condition that affects the quality of the District's influent or effluent in such a manner that inhibits the District's ability to meet receiving water quality, biosolids quality, or air quality requirements established by Regulatory Agencies;
 - 10. Excessive foaming in the sewerage facilities; or

11. Conditions that violate any statute, regulation, or ordinance of any public agency or Regulatory Agency having jurisdiction over the operation of or discharge of wastewater through the sewerage facilities.
 12. Having a temperature higher than 140 degrees Fahrenheit, (60 degrees Centigrade), or which will inhibit biological activity in the treatment plant resulting in Interference, but in case wastewater which causes the temperature at the treatment plant to exceed 104 degrees Fahrenheit (40 degrees Centigrade).
 13. Containing oil, petroleum oil, non-biodegradable cutting or mineral oils or products of mineral oil origin in amounts that will cause interference or pass through.
 14. Containing excessive animal or vegetable oils in amounts that may cause interference, pass through or excessive maintenance to the operation of District's facilities.
- B. No person shall discharge wastewater, delivered by vehicular transport, rail car, or dedicated pipeline, directly or indirectly to the District's sewerage facilities which wastewater contains any substance that is defined as a hazardous waste by the Regulatory Agencies.
 - C. No person shall transport waste from one location or facility to another for the purpose of treating or discharging it directly or indirectly to the District's sewerage system without written permission from the District.
 - D. No user shall increase the contribution of flow, pollutants, or change the nature of pollutants where such contribution or change does not meet applicable standards and requirements or where such contribution would cause the District to violate any Federal, State, or local regulatory permit.
 - E. No User shall introduce or cause to be introduced into the POTW trucked or hauled pollutants, except at discharge points designated by the General Manager in accordance with Section ?? of this ordinance.

203. PROHIBITION OF DILUTION

No user shall increase the use of water or in any other manner attempt to dilute a discharge as a partial or complete substitute for treatment to achieve compliance with this Ordinance and the user's permit or to establish an artificially high flow rate for permit mass emission rates.

204. PROHIBITION OF SURFACE RUNOFF, GROUNDWATER AND UNPOLLUTED WATER

- A. No person shall discharge groundwater, surface runoff, subsurface drainage, or uncontaminated water such as single pass cooling water from air conditioning units directly or indirectly to the District's sewerage facilities except as provided herein. Pursuant to Section 404, et seq., the District may approve the discharge of such water only when no alternate method of disposal is reasonably available or to mitigate an environmental risk or health hazard.
- B. If a Special Purpose Discharge Permit is issued, pursuant to Section 404, for the discharge of such water into a public sewer, the user shall pay the applicable District charges relating to the treatment and disposal of such wastes and shall meet such other conditions as required by the District to further the purposes of this Ordinance.

205. PROHIBITION OF RADIOACTIVE WASTES

No person shall discharge radioactive waste unless:

- A. The person is authorized to use radioactive materials by the State Department of Health or other governmental agency empowered to regulate the use of radioactive materials; and the waste is discharged in strict conformity with current California Radiation Control Regulations (California Code of Regulations, Title 17) for safe disposal; and
- B. The person is in compliance with all rules and regulations of all other applicable regulatory agencies; and

206. LIMITS ON THE USE OF GRINDERS

Waste discharged into a public sewer from industrial or commercial grinders shall be allowed as long as they do not restrict sewer flow and have been approved by the General Manager. Such grinders must shred the waste to a degree that all particles will be carried freely under normal flow conditions prevailing in the public sewer, with no particle greater than one-half inch in any dimension.

207. PROHIBITION ON POINT OF DISCHARGE

No person, except the District involved in maintenance functions of sanitary sewer facilities, shall discharge any wastewater directly into a manhole or other opening in a sewer other than through an approved private sewer lateral, unless approved by the District upon written application by the user and payment of the applicable fees and charges established herein.

208. LIMITS ON WASTEWATER STRENGTH AND CHARACTERISTICS

- A. No person shall discharge wastewater in excess of the District's Local Limits, as adopted and amended from time to time by District Resolution, limiting the concentrations of wastes discharged by a user or any limit listed in the User's discharge permit. Further, no person shall discharge wastewater in violation of any applicable Federal or State discharge regulations.
- B. No user shall discharge or cause to be discharged wastewater to the sewerage system:
 - 1. Having a pH at a volume and concentration that causes the pH of the influent to the treatment plant to be less than 6.0 or greater than 9.0.
 - 2. Containing flow or pollutants, including, but not limited to, ammonia, chemical oxygen demand, total organic carbon, suspended solids, oil and grease of animal or vegetable origin, total dissolved solids, and phenolic compounds released in a discharge at a flow rate and/or pollutant concentration that, either singly or by interaction with other pollutants, will cause pass through or interference with the POTW.
 - 3. Producing a gaseous mixture that is 10% or greater of the lower explosive limit (LEL) or having a closed cup flashpoint of less than 140 degrees Fahrenheit or 60 degrees Centigrade using the test methods specified in 40 CFR 261.21.
 - 4. Containing petroleum oil, non-biodegradable cutting or mineral oils or products of mineral oil origin in amounts that will cause interference or pass through.

5. Containing excessive Oil and Grease animal or vegetable oils in amounts that may cause interference, pass through or excessive maintenance to the operation of District's facilities.
6. Containing material that will readily settle or cause an obstruction to flow in the sewer resulting in interference, such as, but not limited to, sand, mud, glass, metal filings, diatomaceous earth, cat litter, asphalt, pool plaster, dead animals, wood, bones, hair, and fleshings.
7. In violation of any applicable Federal Categorical Pretreatment Standards, State standards or other local regulations covering wastewater disposal or operations.

C. Water Softener Policy

1. No Industrial User shall install, replace, enlarge, or use any apparatus Water Conditioning Device for softening all or any part of the water supply to any premises when such apparatus is an ion-exchange softener or demineralizer of the type that is regenerated at the site of use with the regeneration wastes being discharged to the POTW unless the Water Conditioning Device apparatus is in compliance with the following conditions:
 - a. The wastewater discharge from device complies with all applicable local wastewater discharge limitations;
 - b. The wastewater discharge is monitored for TDS with the results provided to the District; and
 - c. The Industrial User shall maintain an electrical conductivity-controlled discharge valve in proper operating condition at all times. The industrial user shall notify the General Manager within twenty-four (24) hours in the event of a valve failure and immediately cease the discharge of all wastewater to the POTW associated with the soft water regenerating processes. A written report documenting the cause of the failure and the corrective actions taken shall be submitted to the District, within five calendar days after discovery of the electrical conductivity valve failure.
2. Residential Water Softening shall be regulated in accordance with California Health and Safety Code Sections 116775-116795 and amendments thereto, which are hereby incorporated by reference.
3. Any person installing or operating a Water Conditioning Device apparatus of any kind shall make such apparatus device accessible for inspection at reasonable times.
4. The District may limit the availability, or prohibit the installation, of any residential Water Conditioning Device water softening or conditioning appliances that discharge to the POTW if the General Manager makes all of the following findings:
 - a. The POTW is not in compliance with the discharge or water reclamation requirements specified in the Waste Discharge Requirements issued by the Regional Water Quality Control Board;
 - b. Limiting the availability, or prohibiting the installation, of the Water Conditioning Device appliances is the only available means of achieving compliance with Waste Discharge Requirements issued by

the Regional Board; and

- c. All nonresidential sources are limited to the volumes and concentrations of saline discharges to the POTW to the extent technologically and economically feasible.

D. Swimming Pool Policy

1. Discharges from non-saltwater swimming pools, wading pools, spas, whirlpools, and therapeutic pools may be discharged to the District's sewer system on a case-by-case basis as determined by the District. Each person who desires to drain a swimming pool, wading pool, spa, whirlpool, or therapeutic pool shall first obtain permission from the District prior to discharging any of these waters. Permission may be granted by the District if the discharge will:
 - a. Not cause hydraulic overload conditions in any of the District's sewer lines;
 - b. Meets all applicable specific limitations for wastewater quality as established by the District, including but not limited to pH, TDS, chloride, sodium, BOD, and TSS; and
 - c. Commence at a time of day and rate of flow that minimizes the impact of the wastewater system
2. The discharge of salt water pools to the District's Sewer System is prohibited without prior review and is subject to approval on a case by case basis. Written approval may contain specific conditions and must be received prior to initiating any discharge to the District's sewer.

E. Specific Local Limits

1. Except as specifically allowed by the General Manager on a temporary basis or as provided herein, no Class I or Class II User shall discharge or cause to be discharged to the POTW any wastewater unless it conforms to all applicable local discharge limits as set forth by Resolution of the District's Board of Directors. Said discharge limits are amended from time to time as needed to protect the POTW and comply with current and future state and federal regulatory requirements.
2. Local discharge limits apply at the point where the wastewater is discharged to the POTW. The General Manager may impose average daily, monthly and/or mass limits in addition to the concentration based limits set forth by Resolution of the District.
3. The General Manager may authorize the discharge of non-domestic wastewater to the POTW which contains pollutants in concentrations exceeding the specific local pollutant concentration limits adopted by Resolution, when said concentration, in combination with a measured discharge flow rate, do not exceed specific local mass emission rate limits which are computed for the individual discharger on the basis of the local pollutant concentration limits and the discharger's permitted discharge flow rate limit, and which are issued to the discharger as part of the discharger's permit.

F. Categorical Pretreatment Standards

1. Promulgated National Categorical Pretreatment Standards in 40 CFR Chapter I, Subchapter N, Parts 405-471, are incorporated into this Ordinance. Upon promulgation of new or revised categorical pretreatment standards, the new or revised categorical pretreatment standards shall be immediately deemed incorporated herein. The General Manager shall notify affected users of applicable reporting requirements under 40 CFR, Chapter I, subchapter N, Parts 401, et seq.
2. No user subject to categorical pretreatment standards shall discharge or cause to be discharged to the POTW any wastewater which is not in conformance with the discharge limits set forth in the categorical pretreatment standards, including any revision thereof. Notwithstanding the foregoing, a user may obtain a variance from a categorical pretreatment standard in accordance with the provisions of 40 CFR 403.13 and by establishing to the satisfaction of the General Manager, that the discharge will not adversely affect POTW operations and maintenance.
3. In the event that a categorical pretreatment standard establishes a discharge limit which conflicts with a local discharge limit, the more stringent discharge limit shall apply.

209. PROHIBITION ON MEDICAL WASTE

No person shall discharge to the POTW medical wastes from hospitals, clinics, offices of medical doctors, convalescent homes, medical laboratories, other medical facilities, or any other locations except where prior written authorization for such discharges is given by the General Manager following the General Manager's determination that the discharge will not alone or in conjunction with other discharges, adversely affect the operation and maintenance of the POTW. If written authorization for such a discharge is given, the General Manager shall have the authority to require that any discharge of an infectious waste to the sewer be rendered non-infectious prior to discharge if the infectious waste is deemed to pose a threat to the public health and safety or will result in any violation of applicable waste discharge requirements.

210. PROHIBITION ON DISPOSAL OF SPENT SOLUTIONS AND SLUDGES

Spent solutions, sludges, and materials of quantity or quality in violation of, or prohibited by this Ordinance, or any permit issued under this Ordinance must be disposed of in a legal manner at a legally acceptable point of disposal as defined by the District or appropriate Regulatory Agency. All waste manifests shall be retained for a minimum of three years and made available to the District upon request.

211. MASS EMISSION RATE DETERMINATION

- A. Mass emission rates for pollutants that are present or anticipated in the user's wastewater discharge may be set for each user and made an applicable part of each user's permit. These rates shall be based on the District's Local Discharge Limits, or Federal Categorical Pretreatment Standards, and the user's average daily wastewater discharge for the past three years, the most recent representative data, or other data acceptable to the General Manager.
- B. To verify the user's operating data, the District may require a user to submit an inventory of all wastewater streams and/or records indicating production rates, water uses and water evaporation rates.
- C. The District may revise limits or mass emission rates previously established in the discharger's permit at any time, based on: current or anticipated operating data of the

discharger or the District; the District's ability to meet NPDES limits; or changes in the requirements of Regulatory Agencies.

- D. The excess use of water to establish an artificially high flow rate for mass emission rate determination is prohibited.

212. RIGHT OF REVISION

The District reserves the right to establish by Ordinance, Resolution, or in wastewater discharge permits, more stringent standards or requirements on discharges to the District's POTW.



ARTICLE 3
SEWER CONSTRUCTION

301. INTRODUCTION

- A. To provide for maximum public benefit, written authorization for connection to and construction of the District's collection and conveyance systems is required. Standards and regulations established herein and by other District Ordinances provide performance requirements for connecting private sewer laterals, public sewers and sewers from outside the District.
- B. No building, industrial facility or other structure shall be occupied until the owner of the premises has complied with all rules and regulations of District and applicable regulations of the County, or city in which the property is located.
- C. Any user located within the District shall at the user's expense and in accordance with this ordinance, connect the discharge from the building directly to the public sewer within ninety (90) days after the date of official notice to do so. Notice will be given in the event the user has received more than one notice in a 365-day period from a regulatory agency responsible for protecting the public health, the environment, or as determined by the District to protect the public's or the District's interests.
- D. Criteria for a variance:
A developer within the District may apply for a variance from immediate connection to District sewer upon application to the General Manager. The Board may approve a variance subject to the following findings and conditions.

Exceptions, connections to the public sewer will be required: A variance for a building and or project that is located within 1,000 feet of an existing District trunkline, or that has potentially more than five units of service may not be considered.

Required finding: The variance will not create a threat to health and safety or the welfare of the immediate property or to the adjoining properties by having a septic system. A favorable recommendation to the District from the Riverside County Environmental Health Department, the Regional Quality Control Board and the City Building Department shall be required before a finding can be made in favor of a variance.

- E. Conditions of an agreement for conditional variance shall include, but may not be limited to the following:
 - 1. That a recorded agreement shall be entered into that requires connection to the public sewer when the project exceeds ten units of service due to any future expansion.
 - 2. The "project" may be one or more lots, or one or more buildings. "Project" shall be defined in the agreement.
 - 3. The agreement shall require the installation of a "dry sewer" to the public street as a means to connect to future public sewer. Single family projects with lots of 2 ½ net acres shall not have to comply.
 - 4. The agreement shall also require all future owners to connect to the public sewer when it becomes available. That they pay connection capacity fees as required at the time of connection. That they will pay a pro-rata charge set by the District for the public sewer that is installed to provide their service.
 - 5. Failure of the septic system shall be cause for an order to connect to the public

sewer.

6. And other conditions that the District may consider necessary to protect the health and safety and welfare of the public.

302. BUILDING SEWERS, LATERALS AND CONNECTIONS

- A. No person shall construct a private sewer lateral, also referred to as a building sewer, connecting with any public sewer without first obtaining a written permit from the District and paying all required fees and connection charges.
- B. Design and construction of private sewer laterals and their connection to the public sewer shall be in accordance with the requirements of the District, the District's Standard Specifications and at the expense of the applicant.
- C. Cleanouts in private sewer laterals shall be provided in accordance with the California Plumbing Code and the District's Standard Specifications. Cleanouts shall be maintained watertight by the user.
- D. All private sewer laterals shall be tested by the applicant or duly appointed representative during construction in accordance with the District's Standard Specifications. At any time when a private sewer lateral is found not to meet the District's Standard Specifications or more stringent requirements as determined by the District's General Manager to protect the District's facilities and public health, the District may require the user to modify, repair or replace the sewers to bring them into compliance with the District's requirements.
- E. Connection to the public sewer involving an existing private sewer lateral shall be inspected, tested and approved by the District's Inspector prior to final approval of construction. Any damage to the public sewer shall be repaired in conformance with District's Standard Specifications at the cost of the applicant.
- F. Any private sewer lateral that is too low to permit gravity flow to the public sewer shall be lifted by artificial means approved by the General Manager, and discharged to the public sewer at the expense of the owner.
- G. Private sewer laterals and private sewers are owned by the owner of the property receiving service through said lines. The property owner shall be responsible for all cost related to the installation, connection, maintenance, repair, construction, abandonment or removal of private sewer laterals and private sewers. If a "common" private sewer lateral serves more than one property, the properties served by the common lateral own the lateral and are responsible for its maintenance and upkeep.
- H. Upon approval of the District, existing buildings located on property belonging to the same owner may be served with the same tributary sewer lateral during the period of said ownership. However, upon subsequent subdivision or sale of a portion of said property, the owner of said portion not directly connected to a public sewer shall apply for a connection permit and construct a separate private sewer lateral to the public sewer in accordance with District's standards. If said property includes a tenant that is a Class I Permittee (see Article 4), the District may require a separate connection to accurately ascertain the tenant's compliance with discharge standards or assess surcharge fees for use of the sewer.
- I. Any new or existing building with plumbing drain outlets at an elevation that is 12 inches or less above the ground surface of the next upstream

manhole, the property owner shall have and maintain a backwater valve (sewage backflow prevention device).

- J. Any new or existing building where the elevation of any floor is at or below the invert of the district sanitary sewer main, or where a condition exists where a stoppage in the district sewer main will cause the hydraulic grade line to rise above the lowest floor level, the property owner shall have and maintain a Backwater Valve.
- K. Failure of the property owner to install and maintain a Backwater Valve for any of the required conditions, including I and J of this Section, shall relieve the District of any and all responsibilities for any and all damage caused by sanitary sewer flooding.
- L. Should the District become aware of a sewage discharge from a leak, rupture, or other breach in the integrity of the conveyance system from private property to a public right-of-way that, in the District's opinion, may endanger human health or the environment, the District may take the actions necessary to clean-up the sewage spill, take other necessary steps to stop the discharge, and remediate the area to prevent an immediate endangerment. District will assess a fee to the private property owner to recover the costs of the clean-up and remediation in accordance with the District's fee schedule for such services.

303. PUBLIC SEWER CONSTRUCTION

All public sewers shall be permitted, design and constructed in accordance with the District's standards and in accordance with the provisions of this article.

- A. No person shall construct, alter, extend or connect to any public sewer without first obtaining a written permit from the District and paying all fees and connection charges and furnishing bonds, as required. The provision of this Section requiring permits shall not be construed to apply to contractors constructing sewers and appurtenances under contracts awarded and entered into with the District.
- B. Minimum standards for the design and construction of sewers within the District shall be in accordance with the District's Standard Specifications adopted by the Board. Copies will be on file at the District's Office. The General Manager may permit modifications or may require higher standards where unusual conditions are encountered or when necessary to protect the District's facilities.
- C. The Plans, Profiles and Specifications required shall be in accordance with the District's Standard Specifications for Construction.
- D. The requirements of Section 303 A and B of this Ordinance shall be fully complied with before any final subdivision map shall be approved by the General Manager. The final subdivision map shall provide for the dedication for public use of streets, easements or rights of way in which public sewer lines are constructed.
- E. In the event that an easement is required for the extension of the public sewer or the making of connections, the applicant shall procure and obtain Board acceptance of a proper easement or grant of right of way having a minimum width of twenty (20) feet and being sufficient in law to allow the laying and maintenance of such extension or connection.
- F. Only properly licensed contractors shall be authorized to perform the work of public sewer construction within the District. All terms and conditions of the permit issued by the District to the applicant shall be binding on the contractor.

- G. Any person constructing a sewer within a street shall comply with all Federal, State, City and County laws, ordinances, rules and regulations pertaining to the curing of pavement; opening, barricading, lighting and protecting of trenches; backfilling, and repaving thereof and shall obtain all permits and pay all fees required prior to the issuance of a permit by the District.
- H. The District shall require that before final acceptance of any public sewer and before commencement of any waste discharge from a structure to the sewerage system:
 1. The applicant or the contractor on the applicant's behalf, file with the District, "record" drawings showing the actual location of all mains, structures, wyes, laterals, manholes and other changes to the construction drawings; and
 2. The sewerage works shall be tested and shall be complete in full compliance with all requirements of the District's Standard Specifications, including final clean-up and removal of all construction debris, to the satisfaction of the General Manager.

304. OUT OF DISTRICT SEWERS

- A. The District may grant permission to connect any lot or parcel of land outside the District to any public sewer in or under the jurisdiction of the District. The granting of permission for outside areas to connect to District sewers shall be at the option of the Board, subject to state and federal law.
- B. In no event shall such permission be granted unless the applicant shall first enter into a written contract whereby binding self, successors and assignees to abide by all ordinances, rules and regulations in regard to the manner in which such the sewer shall be used and the manner of connection therewith, and also shall agree to pay all fees required for securing the permit and an annual fee in the amount set by District for the privilege of using such sewer.
- C. By entering into a contract with the District, all users connected to the District's facilities agree to the jurisdiction and authority of the District. The authority includes the right to establish limits, conditions, and prohibitions; to establish flow rates or prohibit flows discharged to the District's sewerage facilities; to require the development of compliance schedules for the installation of equipment systems and materials by all users; and to take all actions necessary to enforce its authority. By a separate Agreement or within the Contract to connect, the District may establish a program such that an entity regulating the use of the sewers within the lot or parcel of land outside the District can cooperatively and/or jointly administer a program to ensure compliance with the District's regulations. The Agreement or Contract shall not prevent the District from enforcing its authority on users in non-compliance with this Ordinance.

ARTICLE 4

PRETREATMENT DISCHARGE PERMITS FOR NON DOMESTIC SEWAGE DISCHARGE

401. INTRODUCTION

- A. The wastewater discharge permit shall be in one of five forms and is dependent upon the type of discharger, volume, and characteristics of discharge. The five discharge permit types are:
1. **Class I Wastewater Discharge Permit.** Class I Permits are issued to all users meeting the criteria established for Class I Users as defined in this Ordinance.
 2. **Class II Wastewater Discharge Permit.** Class II Users as defined in this Ordinance will be issued a Class II Permit. If any Class II User or group of Users is determined by the General Manager to individually or as a group, cause or contribute to pass through or interference with, the District's facilities, said user(s) will be issued a Class I Permit.
 3. **Special Purpose Discharge Permit.** Special Purpose Discharge Permits are issued for short time durations and are generally for ground water clean-up projects, nuisance waters, and other waters that are determined to be suitable for discharge to the sanitary sewer system.
 4. **General Wastewater Discharge Permit.** When it has been established that a group of similar type businesses (i.e. food service establishments, photo processing, car washes, dental offices, and automotive repair, etc.) are better regulated using Best Management Practices (BMPs), a general wastewater discharge permit may be issued with conditions and BMP requirements that have been established for a specified business group.
- B. All discharge permits shall contain at a minimum the following:
1. Duration of the permit as defined by each permit type.
 2. Prohibition of transferability.
 3. Effluent limits including Best Management Practices.
 4. Permit application and reapplication due dates as defined by each permit type.
 5. Permit modification as defined by 402.4.
 6. Self-monitoring requirements
 7. Reporting and notification requirements
 8. Recordkeeping requirements.
 9. Statement of applicable civil and criminal penalties for violation of permit and/or ordinance requirements and standards

401.1 HAULED WASTEWATER

- A. Septic tank waste may be introduced into the POTW only at locations designated by the General Manager, and at such times as are established by the General Manager. Such waste shall not violate Article 2 of this ordinance or any other requirements established by the District. The General Manager may require septic tank waste haulers to obtain individual wastewater discharge permits or general permits.
- B. The General Manager may require haulers of industrial waste to obtain individual wastewater discharge permits or general permits. The General Manager may require generators of hauled industrial waste to obtain individual wastewater discharge permits or general permits. The General Manager also may prohibit the disposal of hauled industrial waste. The discharge of hauled industrial waste is subject to all other requirements of this ordinance. 
- C. Industrial waste haulers may discharge loads only at locations designated by the General Manager. No load may be discharged without prior consent of the General Manager. The General Manager may collect samples of each hauled load to ensure compliance with applicable Standards. The General Manager may require the industrial waste hauler to provide a waste analysis of any load prior to discharge.
- D. Industrial waste haulers must provide a waste-tracking form for every load. This form shall include, at a minimum, the name and address of the industrial waste hauler, permit number, truck identification, names and addresses of sources of waste, and volume and characteristics of waste. The form shall identify the type of industry, known or suspected waste constituents, and whether any wastes are RCRA hazardous wastes.

402. CLASS I WASTEWATER DISCHARGE PERMITS

- A. No user requiring a Class I permit shall discharge wastewater without obtaining a Class I Wastewater Discharge Permit.
- B. Class I Wastewater Discharge Permits shall be expressly subject to all provisions of this Ordinance and all other regulations, charges for use, and fees established by the District. The conditions of wastewater discharge permits shall be enforced by the District in accordance with this Ordinance and applicable State and Federal Regulations.
- C. All Class I users proposing to discharge directly or indirectly into the District's sewerage facilities shall obtain a wastewater discharge permit by filing an application pursuant to Section 402.1 and paying the applicable fees pursuant to Section 402.3. For purposes of this Ordinance, a Class I user is any user:
 - 1. Meeting the Significant Industrial User definition; or
 - 2. Discharging five percent or more of the District's current effluent mass loading of any regulated constituent.
 - 3. has in its wastes toxic pollutants as defined pursuant to Section 307 of the Clean Water Act; or Discharging wastewater which may cause, as determined by the General Manager, pass through or interference with the District's sewerage system.

402.1 CLASS I WASTEWATER DISCHARGE PERMIT APPLICATION

- A. Any person required to obtain a Class I Wastewater Discharge Permit shall complete and file with the District, at least ninety (90) prior to commencing discharge, an application on the form prescribed by the District. The discharger shall submit, in units

and terms appropriate for evaluation, the following information.

1. Name, address, assessor's parcel number(s), S.I.C. number(s), description of the manufacturing process or service activity.
2. (Whichever is applicable) name, address of any and all principals/ owners/major shareholders of company; Articles of Incorporation; most recent Report of the Secretary of State; Business License.
3. Volume of wastewater to be discharged.
4. Name of individual who can be served with notices other than officers of corporation.
5. Name and address of property owner, landlord and/or manager of the property.
6. Water supplier and water account numbers.
7. Measurement of Pollutants.
 - a. The categorical pretreatment standards applicable to each regulated process and any new categorically regulated processes for existing sources.
 - b. The results of sampling and analysis identifying the nature and concentration, and/or mass, where required by the standard or by the District, of regulated pollutants in the discharge from each regulated process. The constituents and characteristics shall be determined by a laboratory selected by the discharger and acceptable to the District.
 - c. Instantaneous, daily maximum, and long-term average concentrations, or mass, where required, shall be reported.
 - d. The sample shall be representative of daily operations and shall be analyzed in accordance with procedures set out in Section 103.A of this ordinance. Where the Standard requires compliance with a BMP or pollution prevention alternative, the user shall submit documentation as required by the District or the applicable Standards to determine compliance with the Standard.
 - e. Sampling must be performed in accordance with procedures set out in Section 601.1 of this ordinance.
8. Time and duration of discharge.
9. Number of employees and average hours of work per employee per day.
10. Waste minimization and water conservation practices.
11. Brief description of the nature of operations and average rate of production (including each product produced by type, amount, processes, and rate of production). This description should include a schematic process diagram, which indicates points of discharge to the POTW from the regulated processes.
12. Types of wastes generated, and a list of all raw materials and chemicals used or stored at the facility which are, or could accidentally or intentionally be,

discharged to the PTOW.

13. Type and amount of raw materials processed (average and maximum per day).
 14. Landscaped area in square feet, if applicable.
 15. Tons of cooling tower capacity, if applicable.
 16. EPA Hazardous Waste Generator Number, if applicable.
 17. Slug Load Control Plan (SLCP), which at a minimum, lists the chemicals used or stored on-site, spill prevention, notification procedures, and response procedures necessary to prevent slug discharges or excess flow volumes from entering the District's sewer system.
 18. A list of any environmental control permits held by or for the facility that will be covered by the permit.
 19. Any other information as may be deemed necessary by the District to evaluate the permit application.
- B. Dischargers may be required to submit site plans, floor plans, mechanical and plumbing plans, and details to show all sewers, floor drains, spill containment, clarifiers, pretreatment equipment, and appurtenances by size, location, and elevation and all points of discharge.
- C. Dischargers may also be required to submit information related to the discharger's business operations, processes, and potential discharge as may be requested by the District to properly evaluate the permit application.
- D. After evaluation of the data, the District may issue a wastewater discharge permit, subject to terms and conditions set forth in this Ordinance and as otherwise determined by the General Manager to be appropriate to protect the District's sewerage facilities.
- E. The permit application may be denied if the discharger fails to establish to the District's satisfaction that adequate pretreatment equipment is included within the discharger's plans to ensure that the discharge limits will be met or if the discharger has, in the past, demonstrated an inability to comply with applicable discharge limits.

402.2 CLASS I PERMIT CONDITIONS AND LIMITS

- A. A Class I permit shall contain the following conditions or limits:
1. Mass emission rates and concentration limits, including Best Management Practices, regulating pollutants in accordance with Federal, State and District discharge limits.
 2. Requirements to notify the District in writing prior to modification to processes or operations through which industrial wastewater may be produced or when there may be any substantial change in the volume or character of pollutants in their discharge including but not limited to the potential for a slug discharge or the discharge of hazardous waste as per 403.12(p) and as revised.
 3. Location of the user's on-site sampling point.



4. Requirements to self-monitor the discharge and submit technical reports, production data, discharge reports, documentation associated with Best Management Practices and/or waste manifests, including but not limited to the requirements set forth in 40 CFR section 403.12(o) and as revised.
 5. Requirements for maintaining, for a minimum of three years, plant records relating to wastewater discharge, documentation associated with Best Management Practice, and waste manifests as specified by District.
 6. Requirements to submit copies of tax and water bills.
 - 7.
 8. A requirement that all new source dischargers install and start up any necessary pollution control equipment before beginning discharge, and comply with applicable Federal Categorical Pretreatment Standards within (30) days of the commencement of the discharge.
 9. A requirement that all new source dischargers submit monitoring information that meets the requirements of 40 C.F.R section 403.12(d) within ninety (90) days of commencement of the discharge.
 10. A requirement that the Permittee notify the District immediately of all discharges that could cause problems to the District's operations, including any slug loadings, as defined by 40 C.F.R. section 403.5(b)
 11. A requirement to notify the District in the event of any discharge that may cause a problem to the District's facilities.
 12. A requirement to report all monitoring results from the designated sampling and monitoring location(s).
 13. Requirements and conditions in Section 401.B of this ordinance.
- B. A Class I permit may contain any of the following conditions or limits:
1. Requirements for the user to construct and maintain, at the user's own expense, appropriate pretreatment equipment, pH control, flow monitoring facilities, and sampling facilities.
 2. Limits on rate and time of discharge or requirements for flow regulation and equalization.
 3. Requirements to self-monitor.
 4. Assumed values for COD and suspended solids characteristics that typify the discharger's effluent for determination of the charge for use.
 5. Requirements to develop, submit for approval, and implement such a plan or take such other action that may be necessary to control slug discharges.
 6. Other terms and conditions that may be appropriate to ensure compliance with this Ordinance.
 7. Other terms and conditions determined by the General Manager to be appropriate to protect the sewerage system.

402.3 CLASS I PERMIT FEE

- A. The Class I permit fee shall be in an amount adopted by resolution or Ordinance, as appropriate, of the Board of Directors. The permit fee shall be payable at the time a permit application is submitted for the issuance of a new permit or a renewed permit. Payment of permit must be received by the District prior to issuance of either a new permit or a renewed permit. Permittee shall also pay any delinquent invoices in full prior to permit renewal.
- B. Any permit issued for a location wherein the Permittee is not the property owner may be conditioned upon depositing financial security to guarantee payment of all annual fees and charges to be incurred, in accordance with the provisions of the current District's resolution or Ordinance for fees and charges.
- C. Class I Permit Charge for Use. The purpose of a charge for use is to ensure that each recipient of sewerage service from the District pays its reasonably proportionate share of all the costs of providing that sewerage service. Fees and charges for use shall be in accordance with the current District's resolution or Ordinance, as appropriate, for fees and charges.

402.4 CLASS I PERMIT MODIFICATION OF TERMS AND CONDITIONS

- A. The terms and conditions of an issued permit may be subject to modification and change in the sole determination by the General Manager during the life of the permit based on:
 - 1. The discharger's current or anticipated operating data;
 - 2. The District's current or anticipated operating data;
 - 3. Changes in the requirements of Regulatory Agencies that affect the District; or
 - 4. A determination by the General Manager that such modification is appropriate to further the objectives of this Ordinance.
- B. New source indirect dischargers shall be required to install and start up any necessary pollution control equipment before beginning discharge, and comply with applicable Federal Categorical Pretreatment Standards not to exceed thirty (30) days after the commencement of discharge.
- C. Permittee may request a modification to the terms and conditions of an issued permit. The request shall be in writing stating the requested change, and the reasons for the change. The District shall review the request, make a determination on the request, and respond in writing.
- D. Permittee shall be informed of any change in the permit limitations, conditions, or requirements at least forty-five (45) days prior to the effective date of change. Any changes or new conditions in the permit shall include a reasonable time schedule for compliance.

402.5 CLASS I PERMIT DURATION AND RENEWAL

Class I permits shall normally be issued for a period not to exceed two (2) years but in no case for a period of greater than 5-years. At least 45 days prior to the expiration of the permit, the user shall apply for renewal of the permit in accordance with the provisions of this Article 4.

403. CLASS II WASTEWATER DISCHARGE PERMITS

- A. No user requiring a Class II permit shall discharge wastewater without obtaining a wastewater discharge permit.
- B. Class II Wastewater Discharge Permits shall be expressly subject to all provisions of this Ordinance and all other regulations, charges for use and fees established by the District. The conditions of wastewater discharge permits shall be enforced by the District in accordance with this Ordinance and applicable State and Federal Regulations.
- C. All Class II users proposing to discharge directly or indirectly into the District sewerage facilities shall obtain a wastewater discharge permit by filing an application pursuant to Section 403.1 and paying the applicable fees pursuant to Section 403.3. For purposes of this Ordinance, a Class II user is any user:
 - 1. Discharging waste other than sanitary; and
 - 2. Not otherwise required to obtain a Class I permit.
- D. **EXEMPTIONS:** An discharger may qualify for an exemption from the requirement to obtain a Class II Discharge Permit by obtaining the General Manager’s approval of a “Best Management Practices Plan of Action”. An exemption shall be valid for 5 years. To qualify for an exemption the discharger shall:
 - 1) Not discharge in excess of any discharge limit as set forth in Section 208 of this Ordinance or of any wastewater limitation established by Resolution of the District’s Board of Directors.
 - 2) Shall segregate concentrated and dilute waste streams.
 - 3) Use “Dry” versus “Wet” clean-up methods.
 - 4) Use water conservation methods.
 - 5) Maintain all records of waste disposal.
 - 6) Allow District reasonable access to facilities and records for inspection.
 - 7) Implement an approved “Best Management Practices Plan of Action”.
 - 8) Upon a determination by the General Manager that the user has failed to comply with the forgoing criteria, the exemption shall be invalid and the user shall obtain a Class II Discharge Permit.

403.1 CLASS II WASTEWATER DISCHARGE PERMIT APPLICATION

- A. Any person required to obtain a Class II Wastewater Discharge Permit shall complete and file with the District, prior to commencing discharge, an application on the form prescribed by the District. The discharger shall submit, in units and terms appropriate for evaluation, all necessary information as described in Section 402.1.A. (1-18).
- B. Dischargers may be required to submit site plans, floor plans, mechanical and

plumbing plans, and details to show all sewers, spill containment, clarifiers, pretreatment facilities, and appurtenances by size, location, and elevation for evaluation.

- C. Dischargers may also be required to submit other information related to the discharger's business operations, processes, and potential discharge as may be requested to properly evaluate the permit application.
- D. After evaluation of the data furnished, the District may issue a wastewater discharge permit, subject to terms and conditions set forth in this Ordinance and as otherwise determined by the General Manager to be appropriate to protect the District's system.
- E. The permit application may be denied if the discharger fails to establish to the District's satisfaction that adequate pretreatment equipment is included within the discharger's plans to ensure that the discharge limits will be met or if the discharger has, in the past, demonstrated an inability to comply with applicable discharge limits.

403.2 CLASS II PERMIT CONDITIONS, AND LIMITS

- A. A Class II permit shall contain all of the following conditions or limits:
 - 1. Requirements to notify the District in writing prior to modification to processes or operations through which industrial wastewater may be produced.
 - 2. Location of the user's on-site sample point.
 - 3. Requirements for submission of technical reports, production data, discharge reports, and/or waste manifests pursuant to Section 402.2. A.4
 - 4. Requirements to submit copies of tax and waterbills.
 - 5. Requirements and conditions in Section 401.B of this ordinance.
- B. A Class II permit may contain any of the following conditions or limits:
 - 1. Requirements for the user to construct and maintain, at the user's own expense, appropriate pretreatment equipment, pH control, flow monitoring and/or sampling facilities.
 - 2. Limits on rate and time of discharge or requirements for flow regulation and equalization.
 - 3. Assumed values for COD and suspended solids characteristics that typify the discharger's effluent for determination of the charge for use.
 - 4. Requirements to self-monitor.
 - 5. Requirements for maintaining, for a minimum of three years, plant records relating to wastewater discharge, and waste manifests as specified by District.
 - 6. Other provisions that may be appropriate to ensure compliance with this Ordinance.
 - 7. Other terms and conditions determined by the General Manager to be appropriate to protect the District's sewerage system.

403.3 CLASS II PERMIT FEE

- A. The Class II permit fee shall be in an amount adopted by resolution or Ordinance, as appropriate, of the Board of Directors. The permit fee shall be payable at the time a permit application is submitted for the issuance of a new permit or a renewed permit. Payment of permit must be received by the District prior to issuance of either a new permit or a renewed permit. Permittee shall also pay any delinquent invoices in full prior to permit renewal.
- B. Any permit issued for a location wherein the Permittee is not the property owner may be conditioned upon depositing financial security to guarantee payment of all annual fees and charges to be incurred, in accordance with the current District's resolution or Ordinance, as appropriate, for fees and charges.
- C. Class II Permit Charge for Use. The purpose of a charge for use is to ensure that each recipient of sewerage service from the District pays its reasonably proportionate share of all the costs of providing that sewerage service. Fees and charges for use shall be in accordance with the current District's resolution or Ordinance, as appropriate, for fees and charges.

403.4 CLASS II PERMIT MODIFICATION OF TERMS AND CONDITIONS

- A. The terms and conditions of an issued permit may be subject to modification and change in the sole determination by the General Manager during the life of the permit based on:
 - 1. The discharger's current or anticipated operating data;
 - 2. The District's current or anticipated operating data;
 - 3. Changes in the requirements of Regulatory Agencies that affect the District; or
 - 4. A determination by the General Manager that such modification is appropriate to further the objectives of this Ordinance.
- B. The Permittee shall request a modification to the terms and conditions of an issued permit prior to increasing the contribution of flow, pollutants, or changing the nature of pollutants where such contribution or change will cause the Permittee to be in violation of their permit or this Ordinance. The request shall be in writing stating the requested change, and the reasons for the change. The District shall review the request, make a determination on the request, and respond in writing. The District's approval may be granted or denied.
- C. Permittee shall be informed of any change in the permit limitations, conditions, or requirements at least forty-five (45) days prior to the effective date of change. Any changes or new conditions in the permit shall include a reasonable time schedule for compliance.

403.5 CLASS II PERMIT DURATION AND RENEWAL

Class II permits shall be issued for a period not to exceed five (5) years. At least 45 days prior to the expiration of the permit, the user shall apply for renewal of the permit in accordance with the provisions of this Article 4.

404. SPECIAL PURPOSE DISCHARGE PERMITS

- A. No user requiring a Special Purpose Discharge Permit shall discharge wastewater without obtaining a Special Purpose Discharge Permit.

- B. Special Purpose Discharge Permits shall be expressly subject to all provisions of this Ordinance and all other regulations, charges for use, and fees established by the District. The conditions of wastewater discharge permits shall be enforced by the District in accordance with this Ordinance and applicable State and Federal Regulations.
- C. All Special Purpose Discharge Permit users proposing to discharge directly or indirectly into the Districts' sewerage facilities shall obtain a wastewater discharge permit by filing an application pursuant to Section 404.1 and paying the applicable fees pursuant to Section 404.3. This discharge permit may be granted when no alternative method of disposal is reasonably available, or to mitigate an environmental risk or health hazard.

404.1 SPECIAL PURPOSE DISCHARGE PERMIT APPLICATION

- A. Dischargers seeking a Special Purpose Discharge Permit shall complete and file with the District, prior to commencing discharge, an application in the form prescribed by the District. This application shall be accompanied by the applicable fees, plumbing plans, a detailed analysis of the alternatives for water disposal, or other data as needed by the District for review.
- B. The permit application may be denied if the discharger fails to establish to the District's satisfaction that adequate pretreatment equipment is included within the discharger's plans to ensure that the discharge limits will be met if the discharger has, in the past, demonstrated an inability to comply with applicable discharge limits.



404.2 SPECIAL PURPOSE DISCHARGE PERMIT CONDITIONS AND LIMITS

- A. If monitoring is required because the discharge may impact the District's facilities, the monitoring requirements for the discharge shall be for those pollutants known or suspected to exist in the discharge.
- B. The District may specify and make part of each Special Purpose Discharge Permit specific pretreatment requirements or other terms and conditions determined by the General Manager to be appropriate to protect the District's sewerage facilities, to comply with Regulatory Agencies' requirements, to ensure compliance with this Ordinance, and to assess user charges.
- C. Requirements and conditions in Section 401.B of this ordinance.

404.3 SPECIAL PURPOSE DISCHARGE PERMIT FEE

The special purpose discharge permit fee shall be paid by the discharger in an amount adopted by resolution or Ordinance, as appropriate, of the Board of Directors. Payment of permit fees must be received by the District prior to issuance of either a new permit or a renewed permit. Each Permittee shall also pay delinquent invoices in full prior to permit renewal.

A charge for use to cover all costs of the District for providing sewerage service and monitoring shall be established by the General Manager. A deposit determined by the General Manager to be sufficient to pay the estimated charges for use shall accompany the Special Purpose Discharge Permit application, and said deposit shall be applied to the charges for use.

404.4 SPECIAL PURPOSE DISCHARGE PERMIT MODIFICATION OF TERMS AND CONDITIONS

- A. The terms and conditions of an issued permit may be subject to modification and change in the sole determination by the District during the life of the permit based on:
 - 1. The discharger's current or anticipated operating data;
 - 2. The District's current or anticipated operating data;
 - 3. Changes in the requirements of Regulatory Agencies that affect the District; or
 - 4. A determination by the General Manager that such modification is appropriate to further the objectives of this Ordinance.
- B. A Permittee may request a modification to the terms and conditions of an issued permit. The request shall be in writing stating the requested change, and the reasons for the change. The District shall review the request, make a determination on the request, and respond in writing.
- C. A Permittee shall be informed of any changes in the permit at least forty-five (45) days prior to the effective date of the change. Any changes or new conditions in the permit shall include a reasonable time schedule for compliance.

404.5 SPECIAL PURPOSE DISCHARGE PERMIT DURATION AND RENEWAL

Special purpose discharge permits shall be issued for a period not to exceed three (3) years, but may be renewed as determined by the General Manager. Users seeking permit renewal shall comply with all provisions of this Article 4.

405. GENERAL DISCHARGE PERMIT

The General Discharge Permit contains standard conditions and requirements that are the same for all Users with a specific business classification that are determined by the District to have similar process wastewater producing streams and can be regulated using a common permit. The District may issue a General Discharge Permit when:

- A. The General Discharge Permit will regulate the same or substantially similar types of operations;
- B. The Permittees will discharge the same type of wastes;
- C. The discharges require the same effluent limitations, including Best Management Practices;
- D. The discharges require the same or similar monitoring and reporting requirements; and
- E. In the opinion of the District, the Permittees are more appropriately controlled under a general control mechanism than under individual control mechanisms.

Typical business operations that may fall into a General Discharge Permit category include, but are not limited to, food service establishments; automotive repair shops; car washes; dental offices; and film photo-processing operations. Facilities with a General Discharge Permit will typically be regulated using Best Management Practices that are established for each specific business type.

406.1 GENERAL DISCHARGE PERMIT APPLICATION

- A. Any person required to be covered under a General Discharge Permit shall complete

and file with the District prior to commencing discharge, an application in a form prescribed by the District.

- B. Dischargers may be required to submit mechanical and plumbing plans, and details to show all spill containment internal baffles and valving, clarifiers and appurtenances by size, location, and elevation for evaluation.
- C. Dischargers may be required to submit other information related to the discharger's business operations and potential discharge as may be requested to properly evaluate the permit application.
- D. After evaluation of data furnished, the District may issue a General Wastewater permit, subject to terms and conditions set forth in this Ordinance and as otherwise determined by the General Manager to be appropriate to protect the District's sewerage system.
- E. The permit application may be denied if the discharger fails to establish to the District's satisfaction that adequate pretreatment equipment is included within the discharger's plans to ensure that the discharge limits will be met or if the discharger has, in the past, demonstrated an inability to comply with applicable discharge limits.

406.2 GENERAL DISCHARGE PERMIT CONDITIONS AND LIMITS

The issuance of a General Discharge Permit may include any of the following conditions or limits:

- A. Requirements to develop and implement Best Management Practices as determined by the General Manager to be appropriate to protect the District's sewerage system.
- B. Requirements to develop, submit for approval, and implement such a plan or take such action that may be necessary to control slug discharges.
- C. Requirements for the User to construct and maintain, at the user's own expense, appropriate pretreatment equipment, pH control, flow monitoring facilities and sampling facilities.
- D. Other terms and conditions which may be applicable to ensure compliance with this Ordinance.
- E. Other terms and conditions determined by the General Manager to be appropriate to protect the District's sewerage system.
- F. Requirements and conditions in Section 401.B of this ordinance.

406.3 GENERAL DISCHARGE PERMIT FEE

- A. The General Discharge Permit fee shall be in an amount adopted by resolution, or Ordinance, as appropriate, of the Board. The permit fee shall be payable within forty-five (45) days of invoicing by the District. Payment of permit fees must be received by the District prior to issuance of either a new permit or a renewed permit. Permittee shall also pay any delinquent invoices in full prior to permit renewal.
- B. Any permit issued may be conditioned upon depositing financial security to guarantee

payment of all annual fees and charges to be incurred, in accordance with the provisions of Section 717 of this Ordinance.

- C. General Discharge Permit Charge for Use. A charge for use to cover all costs of the District for providing sewerage service and monitoring shall be established by the General Manager and the board of directors through the most current fee resolution named 'A Resolution of the Board of Directors of Valley Sanitary District Amending Fees and Charges For District Services'. A deposit determined by the General Manager to be sufficient to pay the estimated charges for use shall accompany the General Discharge Permit application, and said deposit shall be applied to the charges for use.

406.4 GENERAL DISCHARGE PERMIT MODIFICATIONS OF TERMS AND CONDITIONS

- A. The terms and conditions of an issued permit may be subject to modification and change in the sole determination by the General Manager during the life of the permit based on:
 - 1. The discharger's current or anticipated operating data;
 - 2. The District's current or anticipated operating data;
 - 3. Changes in the requirements of Regulatory Agencies that affect the District; or
 - 4. A determination by the General Manager that such modification is appropriate to further the objectives of this Ordinance.
- B.  The Permittee shall request a modification to the terms and conditions of an issued permit prior to increasing the contribution of flow, pollutants, or changing the nature of pollutants where such contribution or change will cause the Permittee to be in violation of their permit or this Ordinance. The request shall be in writing stating the requested change, and the reasons for the change. The District shall review the request, make a determination on the request, and respond in writing. The District's approval may be granted or denied.
- C. Permittee shall be informed of any change in the permit limits, conditions, or requirements at least forty-five (45) days prior to the effective date of change. Any changes or new conditions in the permit shall include a reasonable time schedule for compliance.

406.5 GENERAL DISCHARGE PERMIT DURATION AND RENEWAL

General Discharge Permit shall be issued for a period not to exceed five (5) years, but may be renewed as determined by the General Manager. Users seeking permit renewal shall comply with all provisions of this Article 4

ARTICLE 5

FACILITIES REQUIREMENTS

501. DRAWING SUBMITTAL REQUIREMENTS

- A. Persons wishing to construct a public sewer as defined by Section 303 shall submit to the District, the Plans, Profiles and Specifications in accordance with District Standard Specifications for Construction.
- B. Applicants or users discharging non-domestic wastewater may be required to submit three copies of detailed facility plans. The submittal shall be in a form and content acceptable to the District for review of existing or proposed pretreatment facilities, spill containment facilities, monitoring facilities, metering facilities, and operating procedures. The review of the plans and procedures shall in no way relieve the user of the responsibility of modifying the facilities or procedures in the future, as necessary to produce an acceptable discharge, and to meet the requirements of this Ordinance or any requirements of other Regulatory Agencies.
- C. As a minimum, the drawings shall depict the manufacturing process (waste generating sources), spill containment, monitoring or metering facilities, and pretreatment facilities.
- D. The applicant or user shall submit a schematic drawing of the pretreatment facilities, piping and instrumentation diagram, and wastewater characterization report or equivalent as determined by the General Manager.
- E. Users and applicants may also be required to submit for review, site plans, floor plans, mechanical and plumbing plans, and details to show all sewers, spill containment, clarifiers, and appurtenances by size, location, and elevation for evaluation.
- F. The District may require the drawings be prepared by a California Registered Architect, Chemical, Mechanical, or Civil Engineer.

502. PRETREATMENT FACILITIES

- A. All users shall provide wastewater treatment as necessary to comply with this ordinance and shall achieve compliance with Local Limits and all categorical Pretreatment Standards within the time limitations specified by EPA, the State, or District, whichever is more stringent. Any facilities necessary for compliance shall be provided, operated, and maintained at the user's expense. Detailed plans describing such facilities and operating procedures shall be submitted to the District for review, and shall be acceptable to the District before such facilities are constructed. The review of such plans and operating procedures shall in no way relieve the user from the responsibility of modifying such facilities as necessary to produce a discharge acceptable to the District under the provisions of this ordinance.
- B. Any user required to treat or transport wastewater shall ensure that pretreatment facilities are maintained by a qualified operator and in proper operating condition at the user's expense.
- C. All users may also be required by the District to submit waste analysis plans, contingency plans, and meet other necessary requirements to ensure proper operation of the pretreatment facilities and compliance with permit limits and this Ordinance.

- D. No user shall increase the use of water or in any other manner attempt to dilute a discharge as a partial or complete substitute for treatment to achieve compliance with this Ordinance and the user's Permit.

503. SPILL CONTAINMENT FACILITIES/ACCIDENTAL SLUG CONTROL PLANS

- A. All users shall provide spill containment for protection against discharge of prohibited materials or other wastes regulated by this Ordinance. Such protection shall be designed to secure the discharges and to prevent them from entering into the system in accordance with reasonable engineering standards. Such facilities shall be provided and maintained at the user's expense.
- B. The General Manager may require any industrial user to develop and implement an accidental discharge/slug control plan.
- C. The General Manager shall evaluate whether each SIU needs an accidental discharge/slug control plan or other action to control slug discharges. An accidental discharge/slug control plan shall address, at a minimum, the following:
 - 1. Description of discharge practices, including nonroutine batch discharges;
 - 2. Description of stored chemicals;
 - 3. Procedures for immediately notifying the General Manager of any accidental or slug discharge; and
 - 4. Procedures to prevent adverse impact from any accidental or sludge discharge. Such procedures include, but are not limited to, inspection and maintenance of storage areas, handling and transfer of materials, loading and unloading operations, control of plant site runoff, worker training, building of containment structures or equipment, measures for containing toxic organic pollutants, including solvents, and/or measures and equipment for emergency response.

504. MONITORING/METERING FACILITIES

- A. The District may require the user to construct and maintain in proper operating condition at the user's sole expense, flow monitoring, constituent monitoring and/or sampling facilities.
- B. The monitoring or metering facilities may be required to include a security closure that can be locked with a District provided hasp lock or the equivalent, during sampling or upon termination of service.
- C. The location of the monitoring or metering facilities shall be subject to approval by the District.
- D. The user shall provide immediate, clear, safe, and uninterrupted access to the District to the user's monitoring and metering facilities.
- E. The District may at its sole discretion, install its own monitoring or metering facilities. The cost of constructing and maintaining the facilities shall be borne by the user.

505. WASTE MINIMIZATION REQUIREMENTS

The District may require the user to provide waste minimization plans to conserve water, investigate product substitution, provide inventory control, implement employee education, and other steps as necessary to minimize waste produced.

506. GREASE INTERCEPTOR

In accordance with Section 502, a User may be required to install pretreatment facilities to assure that the wastewater is acceptable to the District. Grease Interceptors may be required to remove solids and floating grease that may interfere with the District's facilities. Grease Interceptors are defined as a structural chamber approved by the local authorities and the District to remove fats, oils, and grease (FOG) and solids from wastewater prior to discharge to the District's sewer collection system.

- A. Grease Interceptors are typically required for food service establishments. Discharges from new facilities must have their plumbing plans reviewed and approved by the appropriate plumbing official and reviewed by the District to determine if a Grease Interceptor is required and if it is appropriately sized for the flow and loading generated by the User's discharge.
- B. Sanitary wastewater shall not be allowed to pass- through the Grease Interceptor.
- C. Grease Interceptors shall be operated and maintained in a satisfactory manner which includes cleaning to remove all solids and floatable FOG once every three months, when 25% or more of the volumetric capacity of the chamber is occupied by settled or floatable materials, or when determined by the District, whichever occurs first. Users are required to maintain cleaning records for three years.
- D. District may reduce the cleaning requirements only after the User demonstrates to the satisfaction of the General Manager that the Grease Interceptor can operate at a different cleaning frequency. The User shall submit a demonstration plan for District's approval that includes effluent testing to demonstrate that the Grease Interceptor cleaning frequency can be changed. The User shall execute the plan and submit the results for District's review and approval prior to changing the cleaning frequency.
- E. All chambers of the Grease Interceptor shall be immediately accessible at all times for the purpose of inspection and cleaning. At no time shall any material, debris, obstacles, or obstructions be placed in such a manner so as to prevent immediate access to the interceptor.
- F. All interceptors shall be equipped with a sample chamber located downstream of the interceptor and the sample chamber shall conform to approved District standards.
- G. If the General Manager finds that a Grease Interceptor is inadequate for removing floatable or settleable material or is structurally incomplete, the General Manager shall notify the User that the Grease Interceptor does not meet the requirements of this section and shall require the User to install, at the user's expense, an acceptable interceptor.
- H. The use of chemicals, enzymes, or mechanical means to dissolve or emulsify grease is specifically prohibited.

Accumulated sediment and floating material from the Grease Interceptor shall be removed and legally disposed of and shall not be discharged to the sewer.

ARTICLE 6

MONITORING, REPORTING, NOTIFICATION, AND INSPECTION REQUIREMENTS

601. MONITORING AND REPORTING CONDITIONS

A. Monitoring for Annual Charge for Use

The wastewater constituents and characteristics of a discharger needed for determining the annual charge for use shall be submitted in the form of self-monitoring reports by the user to the District, if requested and as set forth in their permit. The frequency of analyses and reporting shall be set forth in the user's permit. The analyses of these constituents and characteristics shall be by a laboratory acceptable to the District, and at the sole expense of the permittee. Analyses performed by District's personnel may be used in the determination of the annual charge for use.

B. Monitoring for Compliance with Permit Conditions or Reporting Requirements

The District may require reports for self-monitoring of wastewater constituents and characteristics of the discharger needed for determining compliance with any limit or requirements as specified in the user's permit, Federal or State Regulations, or this Ordinance. These reports include:

- (1) Baseline Monitoring Reports as defined by 40 CFR 403.12(b).
- (2) Compliance Schedule Progress Reports as defined by 40 CFR 403.12(c).
- (3) 90-Day Compliance Reports as defined by 40 CFR 403.12(d).
- (4) Periodic Reports on continued compliance, including but not limited to report(s) of continued compliance with categorical standards in accordance with 40 CFR 403.12(e) and other specified limitations (e.g. local limits) in accordance with 40 CFR 403.12 (h).
- (5) Notification of the Discharge of Hazardous Waste as per 40 CFR 403.12(p) and as revised.
- (6) Other reports as required by the District, including but not limited to a report of compliance with any categorical deadline(s) in accordance with 40 CFR 403.12(d).

Monitoring reports of the analyses of wastewater constituents and characteristics shall be in a manner and form approved by the District and shall be submitted upon request of the District. When applicable, the self-monitoring requirement and frequency of reporting may be set forth in the user's permit as directed by the District. The analyses of wastewater constituents and characteristics and the preparation of the monitoring report shall be done at the sole expense of the user.

Failure by the user to perform any required monitoring, or to submit monitoring reports required by the District constitutes a violation and may result in determining whether the permittee is in significant non-compliance, as defined in this Ordinance. Any and all expenses incurred by the District to determine compliance with any limits and requirements specified in the user's permit or in this Ordinance shall be the

responsibility of said user.

601.1 Inspection and Sampling Conditions

- A. The District may inspect and sample the wastewater generating and disposal facilities of any user to ascertain whether the intent of this Ordinance is being met and the user is complying with all requirements.
- B. The District shall have the right to place on the user's property or other locations as determined by the District, such devices as are necessary to conduct sampling or metering operations. Where a user has security measures in force, the user shall make necessary arrangements so that personnel from the District shall be permitted to enter without delay for the purpose of performing their specific responsibilities.
- C. In order for the District to determine the wastewater characteristics of the discharger for purposes of determining the annual use charge and for compliance with permit requirements, the user shall make available for inspection and copying by the District all notices, self-monitoring reports, waste manifests and records including, but not limited to, those related to production, wastewater generation, wastewater disposal, and those required in the Federal Pretreatment Requirements without restriction, but subject to the confidentiality provision set forth in Section 104 herein. All such records shall be kept by the user a minimum of three (3) years.
- D. The user is responsible for maintaining all user required flow and sampling equipment and maintaining the designated sampling location free from debris. Debris removed from the sampling location is considered waste and shall be pretreated and disposed of properly.
- E. Samples collected to satisfy reporting requirements must be based on data obtained through appropriate sampling and analysis performed during the period covered by the report, based on data that are representative of conditions occurring during the reporting period.
- F. All wastewater samples must be representative of the User's discharge. Wastewater monitoring and flow measurement facilities shall be properly operated, kept clean, and maintained in good working order at all times. The failure of a User to keep its monitoring facility in good working order shall not be grounds for the User to claim that sample results are unrepresentative of its discharge.
- G. If a User subject to the reporting requirement in this section monitors any regulated pollutant at the appropriate sampling location more frequently than required by the General Manager or designated representative, using the procedures prescribed in this section of this ordinance, the results of this monitoring shall be included in the report.
- H. Except as indicated in Section I and J below, the User must collect wastewater samples using 24-hour flow-proportional composite sampling techniques, unless time-proportional composite sampling or grab sampling is authorized by the General Manager. Where time-proportional composite sampling or grab sampling is authorized by the District, the samples must be representative of the discharge. Using protocols (including appropriate preservation) specified in 40 CFR Part 136 and appropriate EPA guidance, multiple grab samples collected during a 24-hour period may be analyzed individually or composited prior to the analysis as follows: for cyanide, total phenols, and sulfides the samples may be composited in the laboratory or in the field; for volatile organics and oil and grease the samples may be composited in the laboratory. In addition, grab samples may be required to show

compliance with Instantaneous Limits.

- I. Samples for oil and grease, temperature, pH, cyanide, total phenols, sulfides, and volatile organic compounds must be obtained using grab collection techniques.
- J. For sampling required in support of baseline monitoring and 90-day compliance reports, a minimum of four grab samples must be used for pH, cyanide, total phenols, oil and grease, sulfide and volatile organic compounds. The General Manager may authorize a lower minimum for facilities for which historical sampling data are available.

601.2 Right of Entry

Persons or occupants of premises where wastewater is created or discharged shall allow the District, or its representatives, reasonable access to all parts of the wastewater generating and disposal facilities for the purposes of inspection and sampling during all times the discharger's facility is open, operating, or any other reasonable time. No person shall interfere with, delay, resist, or refuse entrance to authorized District's personnel attempting to inspect any facility involved directly or indirectly with a discharge of wastewater to the District's sewerage system

601.3 Notification of Spill or Slug Loading

- A. In the event the discharger is unable to comply with any permit condition due to a breakdown of equipment, accidents, or human error, or the discharger has reasonable opportunity to know that the discharge will exceed the discharge provisions of the user's permit, Section 208, or any local wastewater discharge limitations adopted by the District, the discharger shall immediately notify the District by telephone. If the material discharged to the sewer has the potential to cause or result in a fire or explosion hazard, the discharger shall immediately notify the local fire department and the District.
- B. Confirmation of this notification shall be made in writing no later than five (5) working days from the date of the incident. The written notification shall state the date of the incident, the reasons for the discharge or spill, what steps were taken to immediately correct the problem, and what steps are being taken to prevent the problem from recurring.
- C. Such notification shall not relieve the user of any expense, loss, damage, or other liability which may be incurred as a result of damage or loss to the District or any other damage or loss to person or property; nor shall such notification relieve the user of any fees or other liability which may be imposed by this Ordinance or other applicable law.

601.4 Notification of Bypass

- A. Bypass of industrial wastewater to the sewerage system is prohibited. The District may take enforcement action against the user, unless:
 - 1. Bypass was unavoidable because it was done to prevent loss of life, personal injury, or severe property damage;
 - 2. There were no feasible alternatives to the bypass, such as the use of auxiliary treatment facilities, retention of untreated wastes, elective slow-down or shut-down of production units or maintenance during periods of production downtime. This condition is not satisfied if adequate backup equipment could

have been feasibly installed in the exercise of reasonable engineering judgment to prevent a bypass that occurred during normal periods of equipment downtime or preventative maintenance; and

3. The permittee submitted notices as required under Article 601.4 (B).
 - B. If a permittee knows in advance of the need for a bypass, it shall submit a written request to allow the bypass to the District, if possible, at least ten (10) days before the date of the bypass.
 - C. The District may approve an anticipated bypass at its sole discretion after considering its adverse effects, and the District determines that the conditions listed in 601.4 (A) (1-3) are met.
 - D. A permittee shall provide telephone notification to the District of an unanticipated bypass that exceeds its permitted discharge limits within four (4) hours from the time the permittee becomes aware of the bypass. A written report shall also be provided within five (5) days of the time the permittee becomes aware or could reasonably have been aware of the bypass. The report shall contain a description of the bypass and its cause; the duration of the bypass, including exact dates and times, and, if the bypass has not been corrected, the anticipated time it is expected to continue; and steps taken or planned to reduce, eliminate, and prevent recurrence of the bypass. Failure to submit oral notice or written report may be grounds for permit revocation.

ARTICLE 7

ENFORCEMENT

701. PURPOSE AND SCOPE

- A. The Board finds that in order for the District to comply with the laws, regulations and rules imposed upon it by Regulatory Agencies and to ensure that the District's sewerage facilities and treatment processes are protected and are able to operate with the highest degree of efficiency, and to protect the public health and environment, specific enforcement provisions must be adopted to govern the discharges to the District's sewerage system.
- B. To ensure that all interested parties are afforded due process of law and that non-compliance and violations are resolved as soon as possible, the general policy of the District is that:
 - 1. Any determination relating to a permit application, permit violation, Probation Order, or Enforcement Compliance Schedule Agreement (ECSA) will be made by the Program Manager, with a right of appeal by the permittee to the General Manager pursuant to the procedures set forth in Section 713.
 - 2. A user, permittee, or applicant for a permit may request the Board to hear an appeal of the General Manager's decision pursuant to Section 715, except as set forth in Section 715.B. Such request may be granted or denied by the Board except where civil penalties have been awarded.
 - 3. Actions and decisions by the Program Manager are made pursuant to a delegation of authority by the General Manager as authorized by Section 107 of this Ordinance.
- C. The District, at its discretion, may utilize any one, combination, or all enforcement remedies in accordance with the District's enforcement response plan to any permit or Ordinance violation. However, the District may take other action against any User when the circumstances warrant. Further, the District is empowered to take more than one enforcement action against any noncompliant user.

702. DETERMINATION OF NON-COMPLIANCE

- A. Sampling Procedures
 - 1. Sampling of all permittees shall be conducted in the time, place, manner, and frequency determined at the sole discretion of the District.
 - 2. Non-compliance with mass emission rate limits, concentration limits, permit discharge conditions, or any discharge provision of this Ordinance may be determined by an analysis of a grab or composite sample of the effluent of a user. Non-compliance with mass emission rate limits shall be determined by an analysis of a composite sample of the user's effluent, except that a grab sample may be used to determine compliance with mass emission rate limits when the discharge is from a closed (batch) treatment system in which there is no wastewater flow into the system when the discharge is occurring, the volume of wastewater contained in the batch system is known, the time interval of discharge is known, and the grab sample is homogeneous and

representative of the discharge.

3. All wastewater samples must be representative of the User's discharge. Wastewater monitoring and flow measurement facilities shall be properly operated, kept clean, and maintained in good working order at all times. The failure of a User to keep its monitoring facility in good working order shall not be grounds for the User to claim that sample results are unrepresentative of its discharge.

703. ENFORCEMENT PROCEDURES AND APPLICABLE FEES

A. Self-Monitoring Requirements as a Result of Non-Compliance

1. If analysis of any sample obtained by the District or by a permittee or user shows non-compliance with the applicable wastewater discharge limits set forth in the Ordinance or in the permittee's discharge permit, the District may impose self-monitoring requirements on the permittee or user.
2. A user shall perform required self-monitoring of constituents in a frequency, at the specific location, and in a manner directed by the District.
3. All analyses of self-monitoring samples shall be performed by an independent laboratory acceptable to the District and submitted to the District in a form and frequency determined by the District.
4. All self-monitoring costs shall be borne by the user.
5. Nothing in this section shall be deemed to limit the authority of the District to impose self-monitoring as a permit condition.

B. Purpose of Non-Compliance Sampling Fees

The purpose of the non-compliance sampling fee is to compensate the District for costs of additional sampling; monitoring, laboratory analysis, sample treatment, disposal, and administrative processing incurred as a result of the non-compliance, and shall be in addition to and not in lieu of any penalties as may be assessed pursuant to Sections 711 and 712. Non-compliance fees are established by Resolution and are amended from time to time to reflect the cost of providing additional oversight to remedy non-compliance with the provisions of this Ordinance or wastewater discharge permit.

C. Non-Compliance Sampling Fees for Composite Samples

1. Each violation of a permittee's permit discharge limit or condition is a violation of this Ordinance. If analysis of any composite sample of a permittee's discharge obtained by the District shows a violation by the permittee of the mass emission rates or concentration limits specified in the permittee's discharge permit or in this Ordinance, then the District may impose non-compliance sampling fees pursuant to fee schedules adopted by the District's Board of Directors.
2. The fees specified in District's resolution for fees and charges 2021-1143, or as superseded, shall be imposed for each date on which the District conducts sampling as a result of a violation by a permittee.

D. Non-Compliance Sampling Fees for Grab Samples and Self-Monitoring Results



1. If analysis of any grab sample analysis of a permittee's discharge shows non-compliance with any concentration limits as set forth in the user's permit or in Section 208, the District may impose non-compliance sampling fees, pursuant to fee schedules adopted by the District's Board, for sampling conducted by the District as a result of a violation by the permittee.
2. If any self-monitoring analysis of a permittee's discharge shows non-compliance with any concentration limits or mass emission rates as set forth in the user's permit or in this Ordinance, the District may impose non-compliance sampling fees, pursuant to fee schedules adopted by the District's Board of Directors, for sampling conducted by the District as a result of a violation by the Permittee.

E. Requirement to Resample

In accordance with 40 CFR 403.12(g)(2), if sampling performed by a User indicates a violation, the User shall notify the District within 24 hours of becoming aware of the violation. The User shall also repeat the sampling and analysis and submit the results of the repeat analysis to the District within 30 days after becoming aware of the violation. Where the District has performed the sampling and analysis in lieu of the User, the District must perform the repeat sampling and analysis unless it notifies the User of the violation and requires the User to perform the repeat analysis.



703.1 ADMINISTRATIVE ORDERS

A. Cease and Desist Orders

Whenever the General Manager finds that a violation of this Ordinance, or the provisions of any discharge permit issued pursuant to this Ordinance has occurred, the General Manager may issue a Cease and Desist Order and direct that those persons not complying with such prohibitions, limitations, requirements or provisions:

- 1) Cease discharge immediately; or
- 2) Comply immediately; or
- 3) Comply in accordance with a time schedule set forth by the District.

703.2 PROBATION ORDER

A. Grounds

In the event the General Manager determines that a User has violated any provisions of this Ordinance, or the terms, conditions and limits of it's discharge permit, or has not made payment of all amounts owed to the District for user charges, non-compliance fees or any other fees, the General Manager may issue a Probation Order, whereby the user must comply with all directives, conditions and requirements therein within the time prescribed.

B. Provisions

The issuance of a Probation Order may contain terms and conditions including but not limited to, installation of pretreatment equipment and facilities, requirements for self-monitoring, submittal of drawings or technical reports, operator certification, audit of waste minimization practices, payment of fees, limits on rate and time of discharge, or other

provisions to ensure compliance with this Ordinance.

C. Probation Order-Expiration

A Probation Order issued by the General Manager shall be in effect for a period not to exceed ninety (90) days.

703.3 ENFORCEMENT COMPLIANCE SCHEDULE AGREEMENT (ECSA)

A. Grounds

Upon determination that a User is in non-compliance with the terms, conditions or limits specified in its permit or any provision of this Ordinance, and needs to modify, construct and/or acquire and install equipment and/or facilities, the General Manager may require the User to enter into an ECSA. An ECSA will, upon the effective date of the ECSA, amend a permittee's permit. The ECSA shall contain terms and conditions by which a User must operate during its term and shall provide specific dates for achieving compliance with each term and condition for construction, modification and/or acquisition and installation of required equipment.

B. Provisions

The issuance of an ECSA may contain terms and conditions including but not limited to requirements for self-monitoring, modification and/or installation of equipment and/or facilities, submittal of drawings or reports, operator certification, audit of waste minimization practices, payment of fees, limits on rate and time of discharge, deposit of performance guarantee, or other provisions to ensure compliance with this Ordinance.

C. ECSA - Payment of Amounts Owed

The District shall not enter into an ECSA until such time as all amounts owed to the District, including user fees, non-compliance sampling fees, deposits, or other amounts due are paid in full, or an agreement for deferred payment secured by collateral or a third party, is approved by the General Manager. Failure to pay all amounts owed to the District shall be grounds for enforcement action to include but not limited to permit suspension or permit revocation as set forth in Section 704 and 705.

D. ECSA - Discharge Suspension/Revocation

If compliance is not achieved in accordance with the terms and conditions of an ECSA during its term, the General Manager may issue an order suspending or revoking discharge privileges and/or a user's discharge permit pursuant to Section 704 and 705 of this Ordinance.

704. SUSPENSION OF DISCHARGE

A. Grounds

The General Manger may suspend any discharge and/or permit when it is determined that a user:

1. Fails to comply with the terms and conditions of an Enforcement Compliance Schedule Agreement (ECSA.)
2. Knowingly provides a false statement, representation, record, report, or other

document to the District.

3. Refuses to provide records, reports, plans, or other documents required by the District to determine permit terms, conditions or limits, discharge compliance, or compliance with this Ordinance.
4. Falsifies, tampers with, or knowingly renders inaccurate any monitoring device or sample collection method.
5. Fails to report significant changes in operations or wastewater constituents and characteristics.
6. Violates a Probation Order.
7. Refuses reasonable access to the user's premises for the purpose of inspection and monitoring.
8. Does not make timely payment of all amounts owed to the District for user charges, non-compliance sampling fees, permit fees, or any other fees imposed pursuant to this Ordinance.
9. Violates any provision of the District's Ordinance or any condition or limit of the user's discharge permit.

B. Notice/Hearing

When the General Manager has reason to believe that grounds exist for discharge suspension, the General Manager shall give written notice thereof by personal service or certified mail to the user setting forth a statement of the facts and grounds deemed to exist, together with the time and place where the charges shall be heard by the General Manager's designee. The hearing date shall be not less than fifteen (15) calendar days nor more than forty-five (45) calendar days after the mailing of such notice.

1. At the suspension hearing, the user shall have an opportunity to respond to the allegations set forth in the notice by presenting written or oral evidence. The hearing shall be conducted in accordance with procedures established by the General Manager and approved by the District's General Counsel.
2. After the conclusion of the hearing, the General Manager's designee shall submit a written report to the General Manager setting forth a brief statement of facts found to be true, a determination of the issues presented, conclusions, and a recommendation.

Upon receipt of the written report, the General Manager shall make the determination and should the General Manager find that grounds exist for suspension of the discharge, shall issue a decision and order in writing within thirty (30) calendar days after the conclusion of the hearing by the designee. The written decision and order of the General Manager shall be personally served or sent by certified mail to the user or its legal counsel/representative at the user's address. In the event that the General Manager determines not to suspend the discharge, the General Manager may order other enforcement actions as appropriate to prevent non-compliance with Ordinance or the user's discharge permit.



C. Effect

1. Upon an order of suspension by the General Manager becoming final, the user shall immediately cease and desist its discharge and shall have no right to discharge any wastewater, directly or indirectly to the District's sewerage system for the duration of the suspension. All costs for physically terminating and reinstating service shall be paid by the user.
2. Any owner or responsible management employee of a business entity or permittee shall be bound by the order of suspension.
3. An order of discharge suspension issued by the General Manager shall be final in all respects on the sixteenth (16th) day after it is personally served or mailed to the user unless a request for hearing is filed with the Board pursuant to Section 715 no later than 4:00 p.m. on the fifteenth (15th) day following such personal service or mailing.

705. PERMIT REVOCATION

A. Grounds

The General Manager may revoke any permit when it is determined that a permittee:

1. Knowingly provides a false statement, representation, record, report, or other document to the District.
2. Refuses to provide records, reports, plans, or other documents required by the District to determine permit terms, conditions, or limits, discharge compliance, or compliance with this Ordinance.
3. Falsifies, tampers with, or knowingly renders inaccurate any monitoring device or sample collection method.
4. Fails to report significant changes in operations or wastewater constituents and characteristics.
5. Fails to comply with the terms and conditions of an ECSA, permit suspension or probation order.
6. Discharges effluent to the District's sewerage system while its permit is suspended.
7. Refuses reasonable access to the permittee's premises for the purpose of inspection and monitoring. 
8. Does not make timely payment of all amounts owed to the District for user charges, non-compliance sampling fees, permit fees, or any other fees imposed pursuant to this Ordinance.
9. Causes interference with the District's collection, treatment, or disposal system.
10. Fails to submit oral notice or written report of bypass occurrence.
11. Violates any condition or limit of its discharge permit or any provision of the District's Ordinance. 

B. Notice/Hearing

When the General Manager has reason to believe that grounds exist for the revocation of a permit, the General Manager shall give written notice by personal service or certified mail thereof to the permittee setting forth a statement of the facts and grounds deemed to exist together with the time and place where the charges shall be heard by the General Manager's designee. The hearing date shall be not less than fifteen (15) calendar days nor more than sixty (60) calendar days after the personal service or mailing of such notice.

1. At the hearing, the permittee shall have an opportunity to respond to the allegations set forth in the notice by presenting written or oral evidence. The revocation hearing shall be conducted in accordance with the procedures established by the General Manager and approved by the District's General Counsel.
2. After the conclusion of the hearing, the General Manager's designee shall submit a written report to the General Manager setting forth a brief statement of facts found to be true, a determination of the issues presented, conclusions, and a recommendation.

Upon receipt of the written report, the General Manager shall make the determination and should the General Manager find that grounds exist for permanent revocation of the permit, shall issue a decision and order in writing within thirty (30) calendar days after the conclusion of the hearing by the designee. The written decision and order of the General Manager shall be personally served or sent by certified mail to the permittee or its legal counsel/representative at the permittee's business address.

In the event the General Manager determines to not revoke the permit the General Manager may order other enforcement actions, including, but not limited to, a temporary suspension of the permit, under terms and conditions that are deemed appropriate.

C. Effect

1. Upon an order of revocation by the General Manger becoming final, the permittee shall permanently lose all rights to discharge any industrial wastewater directly or indirectly to the District's system. All costs for physical termination shall be paid by the permittee.
2. Any owner or responsible management employee of the permittee shall be bound by the order of revocation.
3. Any future application for a permit at any location within the District by any person subject to an order of revocation will be considered by the District after fully reviewing the records of the revoked permit, which records may be the basis for denial of a new permit.
4. An order of permit revocation issued by the General Manger shall be final in all respects on the sixteenth (16th) day after it is personally served or mailed to the permittee unless a request for hearing is filed with the Board pursuant to Section 715 no later than 4:00 p.m. on the fifteenth (15th) day following such personal service or mailing.

706. DAMAGE TO FACILITIES OR INTERRUPTION OF NORMAL OPERATIONS

- A. Any person who discharges any waste which causes or contributes to any obstruction,

interference, damage, or any other impairment to the District's sewerage facilities or to the operation of those facilities shall be liable for all costs required to clean or repair the facilities together with expenses incurred by the District to resume normal operations. Such discharge shall be grounds for suspension of discharge or permit revocation. A service charge of twenty-five percent (25%) of District's costs shall be added to the costs and charges to reimburse the District for miscellaneous overhead, including administrative personnel and record keeping. The total amount shall be payable with forty-five (45) days of invoicing by the District.

- B. Any person who discharges waste which causes or contributes to the District, (1) violating its discharge requirements established by any Regulatory Agency or (2) incurring additional expenses or suffering losses or damage to the facilities, shall be liable for any costs or expenses incurred by the District, including regulatory fines, penalties, and assessments made by other agencies or a court.

707. INDUSTRIAL WASTE PASS THROUGH

Any person whose discharge results in a pass-through event affecting the District or its sewerage facilities shall be liable for all costs associated with the event, including treatment costs, regulatory fines, penalties, assessments, and other indirect costs. The discharger shall submit to the District plans to prevent future recurrences to the satisfaction of the District.

708. TERMINATION OF SERVICE

- A. The District, by order of the General Manager, may physically terminate sewerage service to any property as follows:
 - 1. On a term of any order of emergency suspension or revocation of a permit; or
 - 2. Upon the failure of a person not holding a valid discharge permit to immediately cease discharge, whether direct or indirect, to the District's sewerage facilities.
- B. All costs for physical termination shall be paid by the user as well as all costs for reinstating service.

709. EMERGENCY SUSPENSION ORDER

- A. The District may, by order of the General Manager, suspend sewerage service when the General Manager determines that such suspension is necessary in order to stop an actual or impending discharge which presents or may present an imminent or substantial endangerment to the health and welfare of persons, or to the environment, or may cause interference to the District's sewerage facilities, or may cause the District to violate any State or Federal Law or Regulation. Any discharger notified of and subject to an Emergency Suspension Order shall immediately cease and desist the discharge of all industrial wastewater to the sewerage system.
- B. As soon as reasonably practicable following the issuance of an Emergency Suspension Order, but in no event more than five (5) days following the issuance of such order, the General Manager shall hold a hearing to provide the user the opportunity to present information in opposition to the issuance of the Emergency Suspension Order. Such a hearing shall not stay the effect of the Emergency Suspension Order. The hearing shall be conducted in accordance with procedures established by the General Manager and approved by the District's General Counsel. The General Manager shall issue a written decision and order within two (2) business

days following the hearing, which decision shall be personally served or sent by certified mail to the user or its legal counsel/ representative at that user's business address. The decision of the General Manager following the hearing shall be final and not subject to appeal.

710. INJUNCTION

Whenever a discharger of wastewater is in violation of or has the reasonable potential to violate any provision of this Ordinance, permit condition, or any Federal Pretreatment Standard or requirement as set forth in 40 CFR Section 403.8 et seq., fails to submit required reports, or refuses to allow the District entry to inspect or monitor the user's discharge, the District may petition the appropriate court for the issuance of a preliminary or permanent injunction, or both, as may be appropriate to restrain the continued violation or to prevent threatened violations by the discharger.

711. CIVIL PENALTIES

A. Authority

All users of the District's sewerage system and facilities are subject to enforcement actions administratively or judicially by the District, U.S. EPA, State of California Regional Water Quality Control Board, or the County of Riverside District Attorney. Said actions may be taken pursuant to the authority and provisions of several laws, including, but not limited to: (1) Federal Water Pollution Control Act, commonly known as the Clean Water Act (33 U.S.C. Section 1251 et seq.); (2) California Porter-Cologne Water Quality Act (California Water Code Section 13000 et seq.); (3) California Hazardous Waste Control Law (California Health & Safety Code Sections 25100 to 25250); (4) Resource Conservation and Recovery Act of 1976 (42 U.S.C. Section 6901 et seq.); and (5) California Government Code, Sections 54739-54740.6.

B. Recovery of Fines or Penalties

In the event the District is subject to the payment of fines or penalties pursuant to the legal authority and actions of other regulatory or enforcement agencies based on a violation of law or regulation or its permits, and said violation can be established by District, as caused by the discharge of any user of the District's sewerage system which is in violation of any provision of the District's Ordinance or the user's permit, District shall be entitled to recover from the user all costs and expenses, including, but not limited to, the full amount of said fines or penalties to which it has been subjected.

C. Ordinance

Pursuant to the authority of California Government Code Sections 54739-54740.6, any person who violates any provision of this Ordinance; any permit condition, prohibition or effluent limit; or any suspension or revocation order shall be liable civilly for a sum not to exceed \$25,000.00 per violation for each day in which such violation occurs. Pursuant to the authority of the Clean Water Act, 33 U.S.C. Section 1251 et seq., any person who violates any provision of this Ordinance, or any permit condition, prohibition, or effluent limit shall be liable civilly for a sum not to exceed \$25,000.00 per violation for each day in which such violation occurs. The General Counsel of the District, upon order of the General Manager, shall petition the appropriate court to impose, assess, and recover such penalties, or such other penalties as the District may impose, assess, and recover pursuant to Federal and/or State Legislative authorization.

D. Administrative Civil Penalties

1. Pursuant to the authority of California Government Code Sections 54740.5 and 54740.6, the District may issue an administrative complaint to any person who violates:
 - a) any provision of this Ordinance;
 - b) any permit condition, prohibition, or effluent limit; or
 - c) any suspension or revocation order.
2. The administrative complaint shall be served by personal delivery or certified mail on the person and shall inform the person that a hearing will be conducted, and shall specify a hearing date within sixty (60) days following service. The administrative complaint will allege the act or failure to act that constitutes the violation of the District's requirements, the provisions of law authorizing civil liability to be imposed, and the proposed civil penalty. The matter shall be heard by the General Manager or designee. The person to whom an administrative complaint has been issued may waive the right to a hearing, in which case a hearing will not be conducted.
3. At the hearing, the person shall have an opportunity to respond to the allegations set forth in the administrative complaint by presenting written or oral evidence. The hearing shall be conducted in accordance with the procedures established by the General Manager and approved by the District's General Counsel.
4. After the conclusion of the hearing, the General Manager's designee shall submit a written report to the General Manager setting forth a brief statement of the facts found to be true, a determination of the issues presented, conclusions, and a recommendation.
5. Upon receipt of the written report, the General Manager shall make a determination and should the General Manager find that grounds exist for assessment of a civil penalty against the person, shall issue a decision and order in writing within thirty (30) calendar days after the conclusion of the hearing by the designee.
6. If, after the hearing or appeal, if any, it is found that the person has violated reporting or discharge requirements, the General Manager or Board may assess a civil penalty against that person. In determining the amount of the civil penalty, the General Manager or Board may take into consideration all relevant circumstances, including but not limited to the extent of harm caused by the violation, the economic benefit derived through any non-compliance, the nature and persistence of the violation, the length of time over which the violation occurs, and corrective action, if any, attempted or taken by the person involved.
7. Civil penalties may be assessed as follows:
 - a) In an amount which shall not exceed two thousand dollars (\$2,000.00) for each day for failing or refusing to furnish technical or monitoring reports;
 - b) In an amount which shall not exceed three thousand dollars (\$3,000.00) for each day for failing or refusing to timely comply with any compliance schedules established by the District;

- c) In an amount which shall not exceed five thousand dollars (\$5,000.00) per violation for each day of discharge in violation of any waste discharge limit, permit condition, or requirement issued, reissued, or adopted by the District;
 - d) In any amount which does not exceed ten dollars (\$10.00) per gallon for discharges in violation of any suspension, revocation, cease and desist order or other orders, or prohibition issued, reissued, or adopted by the District.
8. An order assessing administrative civil penalties issued by the General Manager shall be final in all respects on the thirty-first (31st) day after it is served on the person unless an appeal and request for hearing is filed with the Board pursuant to Section 715 no later than the thirtieth (30th) day following such personal service or mailing. An order assessing administrative civil penalties issued by the Board shall be final upon issuance.
 9. Copies of the administrative order shall be served on the party served with the administrative complaint, either by personal service or by registered mail to the person at the business or residence address, and upon other persons who appeared at the hearing and requested a copy of the order.
 10. Any person aggrieved by a final order issued by the Board, after granting review of the order of the General Manager, may obtain review of the order of the Board in the Superior Court, pursuant to Government Code Section 54740.6, by filing in the court a petition for writ of mandate within thirty (30) days following the service of a copy of the decision or order issued by the Board.
 11. Payment of any order setting administrative civil penalties shall be made within thirty (30) days of the date the order becomes final. The amount of any administrative civil penalties imposed which have remained delinquent for a period of sixty (60) days shall constitute a lien against the real property of the discharger from which the discharge resulting in the imposition of the civil penalty originated. The lien shall have no effect until recorded with the county recorder. The District may record the lien for any unpaid administrative civil penalties on the ninety-first (91st) day following the date the order becomes final.
 12. No administrative civil penalties shall be recoverable under Section 711.D for any violation for which the District has recovered civil penalties through a judicial proceeding filed pursuant to Government Code Section 54740.

712. CRIMINAL PENALTIES

Any person who violates any provision of this Ordinance is guilty of a misdemeanor, which upon conviction is punishable by a fine not to exceed \$1,000.00, or imprisonment for not more than thirty (30) days, or both pursuant to Health and Safety Code Section 6523. Each violation and each day in which a violation occurs may constitute a new and separate violation of this Ordinance and shall be subject to the penalties contained herein.

713. APPEALS TO GENERAL MANAGER

A. General

Any user, permit applicant or permittee affected by any decision, action or

determination made by the General Manager's authorized representative may file with the General Manager a written request for an appeal hearing. The request must be sent by certified mail or hand delivered to be received by the District within thirty (30) days of mailing of notice of the decision, action, or determination of the District to the appellant. The request for hearing shall set forth in detail all facts supporting the appellant's request.

B. Notice

The General Manager shall, within fifteen (15) days of receiving the request for appeal, and pursuant to Section 713.A, provide written notice to the appellant of the hearing date, time, and place. The hearing date shall not be more than thirty (30) days from the mailing of such notice by certified mail to the appellant unless a later date is agreed to by the appellant. If the hearing is not held within said time due to actions or inactions of the appellant, then the staff decision shall be deemed final.

C. Hearing

At the hearing, the appellant shall have the opportunity to present information, supporting its position concerning the staff's decision, action, or determination. The hearing shall be conducted in accordance with procedures established by the General Manager and approved by the District's General Counsel.

D. Written Determination

After the conclusion of the hearing, the General Manager (or other designee) shall prepare a report setting forth a brief statement of facts found to be true, a determination of the issues presented, conclusions, and a recommendation whether to uphold, modify or reverse the staff's original decision, action, or determination. The General Manager shall make a determination and shall issue a decision and order within thirty (30) calendar days of the hearing by the designee. The written decision and order of the General Manager shall be personally served or sent by certified mail to the appellant or its legal counsel/representative at the appellant's business address.

The order of the General Manager shall be final in all respects on the thirty-first (31st) day after it is mailed to the appellant unless a request for hearing is filed with the Board pursuant to Section 715, no later than 5:00 p.m. on the thirtieth (30th) day following such mailing.

714. PAYMENT OF CHARGES

A. Except as otherwise provided, all fees, charges and penalties established by this Ordinance are due and payable upon receipt of notice thereof. All such amounts are delinquent if unpaid forty-five (45) days after date of invoice.

B. Any charge that becomes delinquent shall have added to it a penalty in accordance with the following:

1. Forty-six (46) days after date of invoice, a basic penalty of ten percent (10%) of the base invoice amount, not to exceed a maximum of \$1,000.00; and
2. A penalty of one and one-half percent (1.5%) per month of the base invoice amount and basic penalty shall accrue from and after the forty sixth (46th) day after date of invoice.

C. Any invoice outstanding and unpaid after ninety (90) days shall be cause for immediate

initiation of permit suspension or revocation proceedings.

- D. Penalties charged under this Section shall not accrue to those invoices successfully appealed, provided the District receives written notification of said appeal prior to the payment due date.
- E. Payment of disputed charges is still required by the due date during District review of any appeal submitted by permittees.

715. APPEALS TO THE BOARD

A. General

Any user, permit applicant, or permittee adversely affected by a decision, action, or determination made by the General Manager may, prior to the date that the General Manager's order becomes final, file a written request for hearing before the Board accompanied by an appeal fee in the amount established by a separate resolution of the District's Board. The request for hearing shall set forth in detail all the issues in dispute for which the appellant seeks determination and all facts supporting appellant's request.

No later than sixty (60) days after receipt of the request for hearing, the Board shall either set the matter for a hearing, or deny the request for a hearing.

A hearing shall be held by the Board within sixty-five (65) days from the date of determination granting a hearing unless a later date is agreed to by the appellant and the Board. If the matter is not heard within the required time, due to actions or inactions of the appellant, the General Manager's order shall be deemed final.

B. Granting Request for a Civil Hearing.

The Board shall grant all requests for a hearing on appeals concerning permit suspension, revocation, or denial, and civil administrative penalty awards. Whether to grant or deny the request for a hearing on appeals of other decisions of the General Manager shall be within the sole discretion of the Board.

C. Appeal Fee Refund

The appeal fee shall be refunded if the Board denies a hearing or reverses or modifies, in favor of the appellant, the order of the General Manager. The fee shall not be refunded if the Board denies the appeal.

D. Written Determination

After the hearing, the Board shall make a determination whether to uphold, modify, or reverse the decision, action, or determination made by the General Manager.

The decision of the Board shall be set forth in writing within sixty-five (65) days after the close of the hearing and shall contain a finding of the facts found to be true, the determination of the issues presented, and the conclusions. The written decision and order of the Board shall be personally served or sent by certified mail to the appellant or its legal counsel/representative at the appellant's business address.

The order of the Board shall be final upon its adoption. In the event the Board fails to reverse or modify the General Manager's order, it shall be deemed affirmed.

715.1 Appeals of Charges and Fees

Any user, permit applicant, or permittee affected by any decision, action, or determination by the District, relating to fiscal issues of the District in which the user, applicant, or permittee is located, including but not limited to the imposition and collection of fees, such as connection charges, sewer use charges, and special purpose discharge use charges, may request that the District reconsider imposition of such fees or charges. Following review of such a request, the District shall notify the user, permit applicant, or permittee by personal service or certified mail of the District's decision on the reconsideration request. Any user, permit applicant, or permittee adversely affected by the District's decision on the reconsideration request may file an appeal which shall be heard by the Board. The notice of appeal must be received by the District within thirty (30) days of the personal service or mailing of the District's decision on the reconsideration request.

Notwithstanding the foregoing, appeals of non-compliance sampling fees shall be made pursuant to the appeal procedures set forth in Sections 713 and 715.

716. RECOVERY OF COSTS INCURRED BY DISTRICT

In the event any person violates any of the terms and conditions of this Ordinance, or any order, permit, or agreement issued pursuant to this Ordinance, the District shall be entitled to all costs incurred correcting the violation, including but not limited to all construction spill response costs, and reasonable attorney's fees and costs which may be incurred in order to enforce any of said terms and conditions, with or without filing proceedings in court.

717. FINANCIAL SECURITY/AMENDMENTS TO PERMIT

A. Compliance Deposit

Users that have been subject to enforcement and/or collection proceedings may be required to deposit with the District an amount determined by the General Manager as necessary to guarantee payment to District of all charges, fees, penalties, costs and expenses that may be incurred in the future, before permission is granted for further discharge to the sewer.

B. Delinquent Accounts

The District may require an amendment to the permit of any permittee who fails to make payment in full of all fees and charges assessed by the District, including reconciliation amounts, delinquency penalties, and other costs or fees incurred by Permittee.

C. Bankruptcy

Every Permittee filing any legal action in any court of competent jurisdiction, including the United States Bankruptcy court, for purposes of discharging its financial debts or obligations or seeking court-ordered protection from its creditors, shall, within ten (10) days of filing such action, apply for and obtain the issuance of an amendment to its permit.

D. Permit Amendments

The District shall review and examine Permittee's account to determine whether previously incurred fees and charges have been paid in accordance with time requirements prescribed by this Ordinance. The District may thereafter issue an amendment to the User's permit in accordance with the provision of Article 4 and

Section 717 (E) of this Ordinance.

E. Security

An amendment to a waste discharge permit issued pursuant to Sections 717 (B), (C), and (D), may be conditioned upon the Permittee depositing financial security in an amount equal to the average total fees and charges for two (2) calendar quarters during the preceding year. Said deposit shall be used to guarantee payment of all fees and charges incurred for future services and facilities furnished by District and shall not be used by the District to recover outstanding fees and charges incurred prior to the Permittee filing and receiving protection from creditors in the United States Bankruptcy Court.

F. Return of Security

In the Event the Permittee makes payment in full within the time prescribed by this Ordinance of all fees and charges incurred over a period of two (2) years following the issuance of an amendment to the permit pursuant to Sections 717 (B), (C), and (D), the District shall either return the security deposit posted by the Permittee or credit it's account.

718. JUDICIAL REVIEW

A. Purpose and Effect

Pursuant to Section 1094.6 of the California Code of Civil procedure, the District hereby enacts this section to limit to ninety (90) days following final decisions in adjudicatory administrative hearings the time within which an action can be brought to review such decisions by means of administrative mandamus.

B. Definitions

As used in this Section, the following terms and words shall have the following meanings:

1. Decision shall mean and include adjudicatory administrative decisions that are made after hearing, after an award of civil penalties pursuant to Section 711.D, after revoking, suspending, or denying an application for a permit or a license, or after other administrative hearings required to enforce this chapter.
2. Complete Record shall mean and include the transcript, if any exists, of the proceedings, all pleadings, all notices and orders, any proposed decision by the General Manager, the final decision, all admitted exhibits, all rejected exhibits in the possession of the District or its offices or agents, all written evidence, and any other papers in the case.

C. Time Limit for Judicial Review

Judicial review of any decision of the District or its officer or agent may be made pursuant to Section 1094.5 of the Code of Civil Procedure only if the petition for writ of mandate is filed not later than the ninetieth (90th) day following the date on which the decision becomes final. If there is no provision for reconsideration in the procedures governing the proceedings or if the date is not otherwise specified, the decision is final on the date it is made. If there is provision for reconsideration, the decision is final upon the expiration of the period during which such reconsideration can be sought; provided that if reconsideration is sought pursuant to such provision the decision is final for the purposes of this Section on the date that reconsideration is

rejected.

D. Preparation of the Record

The complete record of the proceedings shall be prepared by the District officer or agent who made the decision and shall be delivered to the petitioner within ninety (90) days after the petitioner has filed written request therefore. The District may recover from the petitioner its actual costs for transcribing or otherwise preparing the record.

E. Extension

If the petitioner files a request for the record within ten (10) days after the date the decision becomes final, the time within which a petition, pursuant to Section 1094.5 of the Code of Civil Procedure, may be filed shall be extended to not later than the thirtieth (30th) day following the date on which the record is either personally delivered or mailed to the petitioner or the petitioner's attorney of record, if appropriate.

F. Notice

In making a final decision, the District shall provide notice to the person (s) subject to the administrative decision, that the time within which judicial review must be sought is governed by Section 1094.6 of the Code of Civil Procedure.

G. Administrative Civil Penalties

Notwithstanding the foregoing in Section 718, and pursuant to Government Code Section 54740.6, judicial review of an order of the Board imposing administrative civil penalties pursuant to Section 711.D may be made only if the petition for writ of mandate is filed not later than the thirtieth (30th) day following the day on which the order of the Board becomes final.

ARTICLE 8
SEVERABILITY

801. SEVERABILITY

If any provision of this Ordinance or the application to any person or circumstances is held invalid, the remainder of the Ordinance or the application of such provision to other persons or other circumstances shall not be affected.

**ARTICLE 9
REPEAL**

901. REPEAL

Ordinance No. 2008-117 is hereby superseded in its entirety on the effective date hereof and shall be of no further force or effect. All Ordinances, resolutions, policies, rules and regulations which are inconsistent with this Ordinance are hereby superseded to the extent that they are inconsistent with the provisions of this Ordinance.

**ARTICLE 10
EFFECTIVE DATE**

1001 EFFECTIVE DATE

The effective date of this Ordinance shall be **MONTH XX, 2022**



VSD

**VALLEY SANITARY DISTRICT
INDUSTRIAL PRETREATMENT PROGRAM**

ENFORCEMENT RESPONSE PLAN

Draft June 2022

VALLEY SANITARY DISTRICT INDUSTRIAL PRETREATMENT PROGRAM ENFORCEMENT RESPONSE PLAN

Table of Contents

1.0 INTRODUCTION.....	1
1.1 INDUSTRIAL USER INVENTORY	1
1.2 COMPLIANCE MONITORING	2
1.3 DATA SCREENING	2
1.4 IDENTIFICATION OF VIOLATIONS	3
1.5 ENFORCEMENT PROCEDURES	3
1.6 STAFF RESPONSIBILITIES	4
1.7 TRACKING SYSTEM	5
1.8 SCHEDULING INDUSTRIAL INSPECTIONS	6
2.0 TYPES OF ENFORCEMENT RESPONSES	7
3.0 SIGNIFICANT NONCOMPLIANCE - DETERMINATION OF NONCOMPLIANCE	8
4.0 ENFORCEMENT RESPONSE GUIDE.....	9
5.0 TIME FRAMES FOR RESPONSES.....	12

Appendix A: Notice of Violation

Appendix B: Example significant Noncompliance Calculations (EPA Significant Noncompliance April 15, 1997 guidance)

1.0 INTRODUCTION

Valley Sanitary District (District) doesn't have an approved EPA Pretreatment Program. The Colorado River Basin (Region 7) Regional Water Quality Control Board, in a July 2011 letter acknowledged that the District could have an informal program, because current conditions do not require it to operate a formal program. The District therefore maintains an informal Pretreatment Program with the elements of a formal program, including an Enforcement Response Plan (ERP). The ERP is periodically updated, as needed. This document was previously updated in 2012 and June 2017.

The District implements the ERP through the legal authority provided in the District's Sewer Construction and Use Ordinance (SCUO). All entities discharging nondomestic waste to the POTW are subject to the ERP. The ERP outlines the procedures that are used to identify, document, track and respond to instances of noncompliance with the SCUO (violations). The ERP also provides guidance for selecting the enforcement action most appropriate for a given violation. The District consistently administers and implements all elements of the ERP. The ERP doesn't preclude the District from taking any, all, or any combination of actions against a noncompliant industrial user (IU).

1.1 INDUSTRIAL USER INVENTORY

The General Pretreatment Regulations, 40 CFR 403.8 (f) (1) and (2), require all publicly owned treatment works (POTWs) to identify potential industrial users subject to the requirements of the pretreatment program and to identify the volume and character of pollutants discharged by the industrial users. It is the District's responsibility to enforce these regulations. The first industrial waste survey was conducted by the District in 1993. The survey was primarily based on a search of the City of Indio's business license data. These users were recorded in an industrial user database that is maintained and updated as changes are identified.

In November 2012 the District's consultant documented an Industrial Waste Survey (IWS) investigation using three data sources to update the industrial user database.

A review of the current users is conducted, at minimum, annually. To identify new industrial users prior to sewer connection, the District uses the following resources:

- Plan Check Submittals from the City
- Development Review Committee Meetings
- Requests for Agency Comments
- Site Visits
- Contact from the Chamber of Commerce, Planning Commission, Health Department, Riverside County Hazardous Material Division, and from potential industries

All new industries subject to pretreatment requirements are issued an Industrial Discharge Permit and added to the industrial user database. Data is recorded as new information becomes available from field personnel and inspections.

1.2 COMPLIANCE MONITORING

Compliance monitoring activities conducted by the District are necessary to identify and document violations that can be presented as admissible and irrefutable evidence in administrative actions and legal proceedings. Industrial compliance with applicable regulations is determined and evaluated through:

- Self-monitoring data from industrial users
- Inspections conducted by the District
- Surveillance sampling and analysis conducted by the District
- Evaluation by the District of application information

Self-monitoring data is required from all Class I and Class II industrial users. The self-monitoring report (SMR) forms used are provided by the District to ensure all necessary information is submitted. Each report must be signed by an authorized representative of the industrial user. This data can be used as evidence if violations are identified.

Inspections by the District are conducted to verify compliance and to identify any potential problems or violations. A standard inspection form is used to ensure all necessary observations are made. The form is signed and dated by the inspector. Any noncompliance situations are noted, either on the inspection form or on a separate report, and follow-up inspections are conducted to ensure compliance.

Surveillance sampling conducted by the District and subsequent laboratory analysis of the industrial user's discharge are the most important aspects of compliance monitoring. Both require strict adherence to standard procedures and proper QA/QC procedures. The District's trained inspection personnel collect samples and complete chain-of-custody forms that accompany each sample to a certified laboratory. Chain-of-custody forms track the samples through the analytical process to maintain their correct identity and to assign correct results. Each person receiving custody of the sample is required to update the chain-of-custody.

Information submitted by industrial users on the Industrial Discharge Permit Application is also evaluated for compliance with regulations. The Environmental Compliance Inspector (ECI) reviews the application and determines whether the user has failed to document information necessary to complete the application. The Laboratory and Environmental Compliance Supervisor will review the application and ECI's findings. Failure to disclose vital information is a violation of the permitting program. The application form contains a statement attesting to the accuracy and completeness of the information submitted, which must be signed by an authorized representative of the industrial user.

1.3 DATA SCREENING

Data to be screened and evaluated is generated by industrial self-monitoring and District surveillance sampling. Data generated by these two activities is first reviewed by the ECI and then the Laboratory and Environmental Compliance Supervisor.

Reports submitted by District field or industrial self-monitoring personnel are reviewed for noncompliance violations. Violations are recorded and enforcement actions are

initiated.

Reports submitted as part of compliance schedule activities are screened and tracked manually. Compliance schedules for each industrial user are tracked by the District's ECI. Action is taken if required reports are not received or if compliance dates are missed. The compliance schedule status for each industrial user remains incomplete until after completion of all compliance activities and demonstration of final compliance.

1.4 IDENTIFICATION OF VIOLATIONS

The identification of a pretreatment requirement violation or other instances of industrial user noncompliance (i.e. federal, state and local sanitary sewer discharge regulations), regardless of severity, will initiate the enforcement process. Violations may be identified by a number of activities, the most common of which include:

- Review of District surveillance sampling results
- Review of industrial self-monitoring results
- Spill/accidental discharge reports from industrial users
- 24-hour notification of violations by the industry to the District
- Site visits/inspections by District personnel
- Observations of field personnel
- Information provided by the public or private citizens
- Review of compliance schedule requirements
- Information provided by other agencies

Once violations are identified the ECI implements the appropriate enforcement response required in the program. The Laboratory and Environmental Compliance Supervisor reviews and approves the enforcement response. When determining an appropriate response, particularly one which includes the imposition of penalties and/or fines, the procedures outlined in the Enforcement Response Guide section should be followed. Additional criteria may be used in determining the response, including:

- Magnitude of the violation
- Duration of the violation
- Effect of the violation on the POTWs receiving stream
- Effect of the violation on POTW processes and equipment
- Compliance history of the industrial user
- Good faith of the industrial user
- Pollutants of particular importance to the POTW

1.5 ENFORCEMENT PROCEDURES

All violations identified by the District are reviewed, evaluated, and addressed with the

appropriate enforcement response. The responses should follow the guidelines of the Enforcement Response Guide in Section 4 below.

The majority of enforcement actions begin with issuance of an initial notice of violation. The notice of violation describes the nature of the violation and informs the industrial user that any additional violations may result in escalated enforcement action.

Once the industrial user has been notified of a violation or has knowledge of a condition which is a violation, the industrial user may be allowed up to 30 calendar days to correct the noncompliance before escalation of the enforcement process occurs. This 30 day period applies only to an initial violation. Any violations occurring after this period is evaluated according to program procedures. (NOTE: A repeat occurrence doesn't have to be associated with the same parameter, condition, or procedural requirement that was found in the initial violation). An industry providing results of self-monitoring or District surveillance sampling that is in violation has 30 days to correct whatever condition exists or existed that contributed to the violation. Thereafter, each violation is evaluated for enforcement action. In addition, if a violation occurred during the 30 day correction period, the industry must demonstrate good faith was exercised to prevent or mitigate further violations during that period.

The District typically issues an informal enforcement response, NOV and/or minimum fine for the first violation, minor violations or for infrequent violations (not repeating over a six month period). Escalating enforcement responses and fines are issued for recurring violations, failure to achieve compliance despite formal or informal enforcement, or for major violations.

Violations that fall under more than one category in the enforcement guide should be addressed through the more severe enforcement response. All alleged violations are included in the more severe response.

1.6 STAFF RESPONSIBILITIES

Described below are the responsibilities of personnel involved in the collection and screening of data, organization of enforcement actions, review of actions taken, and general management of the enforcement response procedures. Enforcement responses are listed in the table below as acronyms which are defined in the *Types of Enforcement Responses* section that follows.

Responsible Staff	Task	Associated Enforcement Responses
General Manager	-General oversight of pretreatment program, compliance orders, administrative fines, litigation proceedings, and public notifications. -Review and submit Annual Report letter	AO, CO, AF, CD, LIT

Responsible Staff	Task	Associated Enforcement Responses
Laboratory and Environmental Compliance Supervisor	<ul style="list-style-type: none"> -Review and audit discharge data submitted by regulated industries. -Coordinate sample activities, permitting, and enforcement. - Prepare Annual Report letter -Input industrial self-monitoring data, District surveillance data, and sampling frequencies. -Review permit applications and discharge permits and control mechanisms. -Coordinate activities of field personnel -Review industrial user report submittals -Review enforcement actions above NOV 	SCH, ECSA
Environmental Compliance Inspector	<ul style="list-style-type: none"> -Collect industrial samples, complete chain-of-custody information, deliver samples to lab, coordinate with Supervisor for special enforcement sampling events. -Collect interceptor samples from established designated sites within the District's service area. -Sample for collection system investigations and to determine the sources of problem discharges. -Input industrial self-monitoring data, District surveillance data, and sampling frequencies. -Develop and issue discharge permits and control mechanisms. -Review industrial user report submittals -Respond to spills, accidental discharges, complaints, and reports for Supervisor to use in enforcement actions. - Prepare enforcement actions 	VTN, SV, NOV

1.7 TRACKING SYSTEM

Industrial users are required to submit various reports and information resulting from compliance activities. The required reports or information are logged in the industrial

user database by the District.

The following items may be required from an industrial user by a specific date:

- Self-Monitoring reports
- Industrial discharge applications
- Compliance schedule reports
- Follow-up information subsequent to industrial inspections
- Written reports following spills, accidental or slug discharges
- Written response to notices of violations
- Scheduled inspection dates

Reports, forms, and correspondence with specific due dates are tracked by the District. These documents are submitted periodically and are tracked within the industrial user database. The ECI is responsible for tracking progress report due dates. The industrial user database is used for tracking responses to inspection activities and notices of violation. The Laboratory and Environmental Compliance Supervisor verifies completion.

All supporting documentation regarding a violation and enforcement actions taken are documented in the industrial user's file.

1.8 SCHEDULING INDUSTRIAL INSPECTIONS

Each facility permitted under the District's Pretreatment Program must be inspected, at minimum, annually. However, many facilities will receive multiple inspections/visits during a given year to track compliance schedule activities, verify changes in discharge or processes, maintain a regulatory presence, and scrutinize facilities with discharges most likely to impact the POTW.

Scheduling of regular annual inspections is done randomly by reviewing the current industrial user list and selecting a day and time in a monthly planning database for the facilities to be inspected. Depending on the industry, advance notice may be given by letter or telephone of the impending inspection. As an industry is inspected, the date is recorded in an industrial user database to ensure each facility is inspected at least once per calendar year, as dictated by program requirements.

Other inspections or site visits are conducted as needed. Facilities operating under a compliance schedule are given priority for follow-up visits to verify progress and to document requirements are being complied with. Inspections of these facilities may take place at regular intervals by recording inspection dates in the schedule database in advance. Inspections may also be scheduled at the request of an industrial user to verify compliance with certain requirements or to identify potential problems.

Inspections are not scheduled in advance if a spill, accidental discharge, extraordinary event, or any other event requiring District surveillance occurs. These are often referred to as demand inspections and are conducted as needed.

At the beginning of the fourth quarter of each calendar year, the industrial user

database is reviewed to determine if all facilities have been inspected or are scheduled for an inspection in the current year. Any industries which haven't been inspected are scheduled for an inspection to occur before the end of the calendar year.

2.0 TYPES OF ENFORCEMENT RESPONSES

The following enforcement options are available to the District staff, along with the acronyms commonly used to identify those actions. The responses are listed in increasing order of severity.

VTN – Verbal Telephone Notice: Is meant to describe a response to a very minor type of violation, which is normally conveyed verbally, to the contact person at the industry and no further follow-up is expected. An example would be a report being received one or two days late.

SV – Site Visit: A visit to the industrial facility to discuss and observe any problems. This can be a substitution for **VTN**. The **SV** can also be made in conjunction with a Notice of Violation (**NOV**). The **SV** also can require a response within 10 days, describing the reason for the noncompliance and what steps are being taken to eliminate any further violations of the same nature. A field inspection sheet needs to be filled out also.

WN – Warning Notice: An informal written notice to describe a response to a very minor type of violation, which is normally conveyed by email or using a standard inspection form to document the violation, to the contact person at the industry. It may be that no further follow-up is needed, or the industry contact may be asked to provide acknowledgement of the issue or describe the corrective action taken.

NOV – Notice of Violation: The Notice of Violation (NOV) is a formal written notice issued after noncompliance with the Warning Notice or other informal enforcement response. The NOV may also be issued for a first-time significant violation. The NOV implements increased monitoring by the Industrial User to ensure compliance with permit and/or ordinance discharge requirements. The NOV (see Appendix A) is sent with a cover letter to the authorized representative of the industrial user.

SCH – Show Cause Hearing: Is a meeting to show cause why a proposed enforcement action should not be taken. Notice is served on the user specifying the time and place for the meeting, the proposed enforcement action, the reasons for such action, and a request that the user show cause why this proposed enforcement action shouldn't be taken. The notice of the meeting is served personally or by registered or certified mail (return receipt requested) at least 10 days prior to the hearing. Such notice may be served on any authorized representative of the user. Whether or not the user appears as ordered, immediate enforcement action may be pursued following the hearing date. A show cause hearing is not a prerequisite for taking any other action against the user.

AO – Administrative Order: An Administrative Order would be used in cases where the District believed the Industrial User was committed to providing necessary measures to correct previous violations and would utilize the Administrative Order to outline compliance schedules, along with other conditions that might be required, such

as additional monitoring, more reporting, etc. The order would normally contain a short timeframe of above one month to six months. Some types of Administrative Orders are

- Cease and Desist Order, directs users to cease discharge immediately, or comply immediately, or comply in accordance with a time schedule set forth by the District; and
- Probation Order, directs users to comply with all directives, conditions, and requirements, including payment of fees, and is issued for a maximum period of 90 days.

CO – Consent Order: A Consent Order combines the force of an AO with the flexibility of a negotiated settlement. The Consent Order is an agreement between the District and the industrial user normally containing three elements: (1) compliance schedules; (2) stipulated fines or remedial actions; and (3) signatures of District and industry representatives.

ECSA – Enforcement Compliance Schedule Agreement: This is a Formal Enforcement Compliance Schedule signed by both the District and the industry involved. This control mechanism is used when serious or long-term violations of discharge limits occur that require the design and installation of new or additional pretreatment equipment. Usually the timeframe is six months to one year. Violations of the ECSA can result in the next step, consisting of administrative fines.

AF – Administrative Fine: An administrative fine would be administered in such cases where all lower types of enforcement responses have failed and/or where deemed appropriate by the District due to the nature and/or intent of the violation. The next response step is court action. The administrative fine step exists in an effort to prevent court action and to correct the problem and/or show the seriousness of the problem to the industry involved. The maximum fine is \$1,000 per violation with each day being considered a separate violation. The administrative fine may also be part of an AO or an ECSA or may be instituted as the next step above an AO.

CD – Cease Discharge: The District has several mechanisms it can use to cause users to stop discharging: Suspension of Discharge, Permit Revocation or Termination of Service. These are described in the District’s Sewer Construction and Use Ordinance.

LIT - Litigation: Litigation is used to define several courses of action, including civil suits for injunctive relief and/or civil penalties, criminal suits, termination of service, etc. These types of actions would involve the courts and the District’s legal counsel and would follow the procedures necessary for due process.

3.0 SIGNIFICANT NONCOMPLIANCE

A list of any Significant Industrial Users (SIUs) found to be in Significant Noncompliance (SNC) is published in the local newspaper. Industrial users are considered to be in SNC if any of the following conditions are met:

1. Chronic violations where 66% or more of all the measurements taken for the same pollutant parameter during a 6-month period exceed (by any magnitude) a numeric Pretreatment Standard or Requirement, including

instantaneous limits, as defined by 40 CFR 403.3(l).

2. Technical Review Criteria (TRC) are defined as those violations in which 33% or more of wastewater measurements taken for the same pollutant parameter during a 6-month period equal or exceed the product of the numeric Pretreatment Standard or Requirement including instantaneous limits, as defined by 40 CFR 403.3(l), multiplied by the applicable TRC listed below. (See Appendix B for example calculations).
 - **TRC = 1.4** for Group I conventional pollutants (BOD, TSS, fats, oil, and grease)
 - **TRC = 1.2** for Group II all other pollutants except pH
3. Any other discharge violation that the District believes has caused, alone or in combination with other discharges, interference or pass through, including endangering the health of POTW personnel or the public.
4. Any pollutant discharge that has caused imminent endangerment to the public or to the environment or has resulted in the District's exercise of its emergency authority to halt such a discharge.
5. Failure to meet, within 90 days of the scheduled date, a compliance schedule milestone contained in a wastewater discharge permit or enforcement order for starting construction, completing construction, or attaining final compliance.
6. Failure to provide within 45 days after the due date, any required reports, including baseline monitoring reports, reports on compliance with categorical pretreatment standard deadlines, periodic self-monitoring reports, and reports on compliance with compliance schedules.
7. Failure to accurately report noncompliance.
8. Any other violation, which may include a violation of Best Management Practices, that the District determines will adversely affect the operation or implementation of the local pretreatment program.

4.0 ENFORCEMENT RESPONSE GUIDE

NONCOMPLIANCE	NATURE OF THE VIOLATION	RANGE OF RESPONSE
Failure to sample, monitor, report (routine reports), or provide baseline monitoring report	Isolated or infrequent	VTN, SV, WN, NOV , and report required within 10 days
	Uncorrected 30 days or more	AO, ECSA, AF , and/or LIT

NONCOMPLIANCE	NATURE OF THE VIOLATION	RANGE OF RESPONSE
Failure to notify of effluent limit violation or slug discharge	Isolated or infrequent. No known effects	NOV or AO
	IU does not respond to letters, does not follow through on verbal or written agreement, or frequent violation	SCH, AO, AF, and/or LIT including penalties
	Frequent or continued violation	AF and/or LIT including penalties
Minor sampling, monitoring or reporting deficiencies (i.e., computational or typographical errors)	Isolated or infrequent	VTN, SV, WN, or NOV Corrections to be made on next submittal.
	Continued violation(s)	NOV, and/or AO
Major or gross sampling, monitoring or reporting deficiencies (i.e., missing information or late reports)	Known environmental or POTW damage	AO, AF, CO, ECSA and/or CD
	Continued violations	AO, AF, CO, ECSA and/or LIT
Reporting false information	Any instance	AO, AF and/or LIT including penalties
Missed interim date	Will not delay final date or other interim dates	VTN, SV, WN, or NOV
	Will result in other missed interim dates. Violation for good or valid cause	NOV, SV and/or AO
	Will result in other missed interim dates. No good or valid cause	NOV, AO, SCH, and/or LIT
	Violation due to strikes, act of God, etc.	SCH ; Contact permittee and require documentation of good or valid cause

NONCOMPLIANCE	NATURE OF THE VIOLATION	RANGE OF RESPONSE
	90 days or more outstanding. Failure or refusal to comply without good or valid cause	AO, AF, and/or LIT including penalty
		
Failure to install monitoring equipment	< 30 days late or isolated event	NOV
	Continued failure	AO and/or AF ; Begin monitoring (using outside contracts, if necessary) and install equipment immediately
Exceeding limits (categorical, local, or prohibited) or BMP violation	Infrequent or isolated minor violation	VTN, SV, WN or NOV with or without non-compliance sampling fees ¹ assessed
	Infrequent or isolated major violations ² ; exceed the limits of a single effluent limit set forth by the TRC	NOV, AO, AF and/or LIT including penalty if environmental harm resulted and non-compliance sampling fees assessed
	Violation(s) which are SNC	NOV, AO, ECSA, AF, and/or LIT including penalty with or without non-compliance sampling fees assessed
	Recurring violation without known damages	NOV and/or AO with or without non-compliance sampling fees assessed

¹ The District may impose non-compliance sampling fees. The purpose of the non-compliance sampling fee is to compensate the District for costs of additional sampling; monitoring, laboratory analysis, sample treatment, disposal, and administrative processing incurred as a result of the non-compliance, and is in addition to and not in lieu of any other administrative fees that may be assessed. Non-compliance fees are established by Resolution.

² Major violation is a discharge exceeding a mass emission limit by 20% or more, discharge exceeding a concentration limit by 20% or more, or a pH discharge less than 5.0 or equal to or greater than 12.5.

NONCOMPLIANCE	NATURE OF THE VIOLATION	RANGE OF RESPONSE
	Results in known environmental or POTW damage	AO, ECSA, AF, CD and/or LIT Including penalty and non-compliance sampling fees assessed
Reported slug load	Isolated without known damage	NOV, AO, and/or SCH
	Isolated with known interference, pass through, or damage	AO, AF, and/or LIT including penalty
	Recurring	LIT including penalty
Discharge without a permit or approval	One time without known environmental damage or continuing violation	AO
	One time which results in environmental damage or continuing violation	AO, AF, and/or LIT including penalty. Request for criminal investigation
	Continuing violation with known environmental damage	LIT including penalty. Request for criminal investigation and disconnect sewer
Minor violation of analytical procedures	Any instance	VTN, SV, or WN
Major violation of analytical procedures	No evidence of intent	NOV and/or AO
	Evidence of negligence or intent	AO, AF, CD and/or LIT including penalty; possible criminal action
Minor violation of permit condition	No evidence of negligence or intent	VTN, SV, WN or NOV ; immediate correction required
	Evidence of negligence or intent	AO, AF, CD and/or LIT including penalty; possible criminal action
Major violation of permit condition	Evidence of negligence or intent	AO, AF, CD and/or LIT including penalty; possible sewer disconnection

5.0 TIME FRAMES FOR RESPONSE

- All violations will be identified and documented within five (5) working days of

- receiving compliance information.
- Initial enforcement responses (involving contact with the industrial user and requesting information on corrective or preventative action (s) will occur within thirty (30) days of violation.
 - Follow-up actions for continuing or recurring violations will be taken within sixty (60) days of the initial enforcement response. For all continuing violations, the response will include a compliance schedule.
 - Violations that threaten health, property, or environmental quality are considered emergencies and will receive immediate responses such as halting the discharge or terminating service.
 - All violations meeting the criteria for SNC will be addressed with an enforceable order within thirty (30) days of the identification of significant noncompliance.

**APPENDIX A
NOTICE OF VIOLATION FORM**

APPENDIX B
EXAMPLE SIGNIFICANT NONCOMPLIANCE CALCULATIONS
(EPA Significant Noncompliance April 15, 1997 guidance)

Valley Sanitary District

Local Limits Review

Submitted in compliance with Order R7-2020-0007



April 2022

Prepared by:

EOA, Inc.

1410 Jackson St.

Oakland, CA 94612



TABLE OF CONTENTS

1.0	Introduction	1
1.1	Purpose.....	1
1.2	Facility Description.....	1
2.0	Pollutants of Concern	3
2.1	National Pollutants of Concern.....	3
2.2	Receiving Water Quality Criteria	3
2.3	Biosolids Criteria	4
2.5	Human Health and Safety Criteria.....	4
2.6	Air Quality Criteria	5
2.7	Summary of Pollutants of Concern Included in Analysis.....	5
3.0	Maximum Allowable Headworks Loading Analysis	5
3.1	Description of MAHL Methodology	5
	Development (or Revision) of Local Limits	7
3.2	Data Sources	7
	Wastewater Flows	8
	Sludge and Biosolids Flows	9
	Plant Influent/Effluent Data	9
	Biosolids Data	10
	Domestic/Background Data	10
	Industrial Data	11
3.3	Removal Efficiencies	11
3.4	MAHL Analysis.....	11
	AHL Based on NPDES Permit Limits or Receiving Water Criteria (Pollutant Pass-Through).....	11
	AHL Based on Biosolids Reuse Criteria.....	13
	AHL Based on Process Inhibition.....	13
	AHL Based on Plant Capacity	13
	MAHL Determination.....	13
3.5	Discussion of MAHL Results and Recommendations.....	17
4.0	Summary and Conclusions.....	19
5.0	References	20

LIST OF TABLES

Table 1. Order R7-2020-0007 Reasonable Potential Triggers and RPA Results4
Table 2. General Parameters9
Table 3. Analytical Methods and No. of Samples 10
Table 4. Allowable Headworks Loading (AHL) Based on NPDES Permit Limits or
Applicable Water Quality Objective..... 12
Table 5. Allowable Headworks Loading Based on Biosolids Disposal Criteria 14
Table 6. Allowable Headworks Loading Based on Process Inhibition..... 15
Table 7. Maximum Allowable Headworks Loading (MAHL) 16
Table 8. Comparison of Influent Loadings to MAHL 18

LIST OF FIGURES

Figure 1. Wastewater Treatment Plant Flow Schematic 2
Figure 2. Molybdenum Biosolids Concentration 17

APPENDICES

Appendix A. Equations Used to Calculate Allowable Headworks Loadings and MAHL
Appendix B. Source Data
Appendix C. Calculation of Surrogate Effluent Limits Based on Applicable Water Quality
Objectives
Appendix D. Current Local Limits
Appendix E. Pretreatment Program Industrial Discharger Information

1.0 INTRODUCTION

1.1 Purpose

This report presents a review and evaluation of local discharge limits for the Valley Sanitary District (District) Wastewater Treatment Plant (WWTP), which discharges to Coachella Valley Storm Water Channel under an NPDES permit (Order No. R7-2020-0007) adopted by the Colorado River Basin Water Quality Control Board (Water Board) on March 5, 2020 (effective date April 1, 2020). The review analyzes recent performance and pollutant loading data to determine if the District's current local limits (Appendix D) continue to meet the requirements of Federal Pretreatment Regulations, which are to 1) protect the WWTP from pass through (i.e. violations of permit effluent limits or applicable water quality objectives), 2) protect WWTP treatment processes from interference, and 3) maintain the level of sludge quality needed to support sludge reuse or disposal practices. The review generally conforms with guidance provided by EPA's July 2004 *Local Limits Development Guidance (Guidance Manual)*. The review is based on the Maximum Allowable Headworks Loading (MAHL) approach, EPA's recommended approach for developing and reviewing local limits.

1.2 Facility Description

The Vall District's WWTP treats wastewater from primarily residential sources serving the City of Indio as well as portions of the City of Coachella, and unincorporated communities in Riverside County. The WWTP has an average dry weather flow (ADWF) design capacity of 13.5 million gallons per day (mgd). The current (2019-2022 average) plant influent flow is 5.7 mgd. The treatment process consists of influent pumping, influent screening, grit removal, primary clarification, activated sludge secondary treatment, oxidation pond secondary treatment, secondary clarification, chlorine disinfection, and dechlorination. Final effluent is discharged to the Coachella Valley Storm Water Channel.

Primary sludge from the primary clarifiers is pumped to the anaerobic digester. Excess solids from the activated sludge treatment system are pumped to either one of the two oxidation system cells or oxidation pond for stabilization. Solids from the digester and oxidation pond system are pumped to the belt presses for dewatering. Dewatered solids are then placed in the onsite storage/drying beds for further moisture reduction prior to final disposal. Sludge is typically removed from the facility site every 12 to 18 month and transported to a dedicated land disposal site (DLD) in Arizona for land application by a contracted sludge disposal company. Screenings and grit are collected in a transportable dumpster, which is hauled to a landfill approximately every two weeks. Schematics of the WWTP liquid and solids treatment processes are included as Figure 1.

The wastewater collection system collects and transports wastewater flows to the treatment plant through XXX miles of gravity sewer mains, XX miles of pressure sewer mains, and XX pump stations.

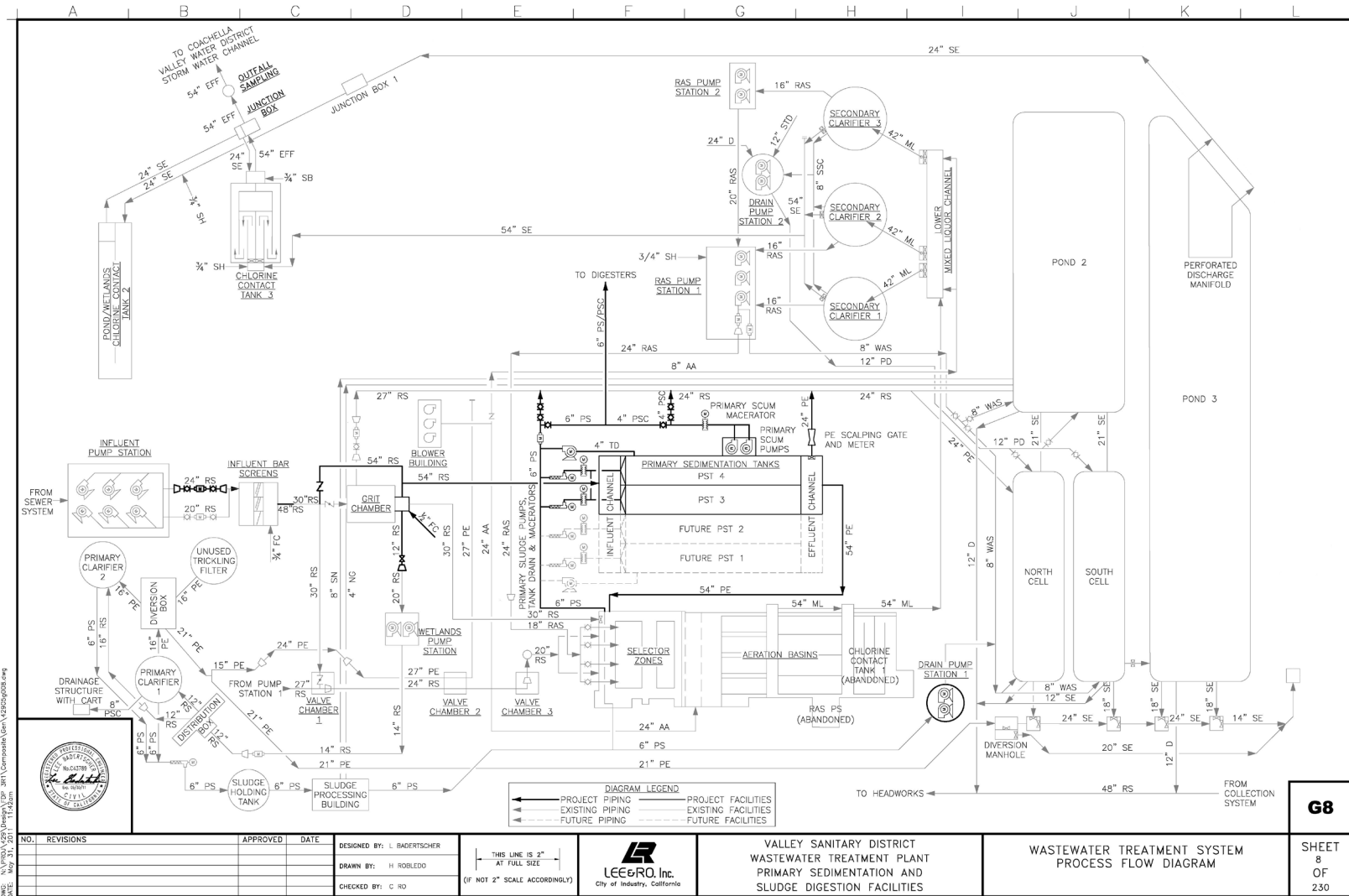

Figure 1. Valley Sanitary District Wastewater Treatment Plant Flow Schematic

The District's Pretreatment Program monitors and controls the quality and quantity of wastewater discharged to the WWTP from industrial sources. The program had 3 permitted Significant Industrial Users (SIUs) in 2020. All three are Non-Categorical Industrial Users under the federal Pretreatment regulations. These three SIUs are subject to local limits only. In 2020, the total regulated process flow from all IUs was approx. 0.05 mgd, or 0.9 % of the plant influent flow. Summary information for the industrial dischargers is presented in Appendix E.

2.0 POLLUTANTS OF CONCERN

2.1 National Pollutants of Concern

The EPA's *Guidance Manual* defines pollutants of concern as:

“...any pollutant which might reasonably be expected to be discharged to the POTW in quantities which could cause pass through or interference with the POTW, contaminate the sludge, or jeopardize POTW worker health and safety.”

In addition to any pollutants that meet this definition, EPA has identified 15 pollutants often found in POTW sludge and effluent that it considers potential pollutants of concern (POCs). These 15 “National POCs” are arsenic, cadmium, chromium, copper, lead, mercury, molybdenum, nickel, selenium, silver, zinc, cyanide, BOD₅, TSS, and ammonia.² Additional POCs were identified by examining other criteria, as described below.

2.2 Receiving Water Quality Criteria

As stated in the Section 3.2.2 of the *Guidance Manual*, EPA recommends that any pollutant that has “reasonable potential” to be discharged in amounts that could exceed water quality standards or criteria should be considered a POC and evaluated accordingly. As part of the reissuance process for the WWTP's current NPDES permit, Water Board staff analyzed effluent data from the WWTP to identify those pollutants that had reasonable potential (RP) to cause or contribute to an excursion above any applicable priority pollutant criterion or objective (WQO). This analysis is referred to as a Reasonable Potential Analysis (RPA). Constituents found to have RP are required to have water quality-based effluent limits in the permit. In addition, the Colorado River Basin Plan requires that NPDES permits have effluent limits for certain pollutants.³

The Water Board's RPA was based on NPDES effluent and Pretreatment Program monitoring data from October 2015 through October 2018⁴ and included all California Toxics Rule (CTR) constituents. The RPA was conducted in accordance with the March 2005 *Policy for Implementation of Toxics Standards for Inland Surface Water, Enclosed Bays, and Estuaries in California* (SIP),

² Ammonia is recommended for POTWs that accept non-domestic sources of ammonia. No IU discharges ammonia to the treatment plant. Ammonia was not included as a pollutant of concern for this analysis.

³ Permits may also contain technology-based effluent limits, as in the case of BOD and TSS.

⁴ The Water Board's RPA analyzed samples collected during the period from October 2015 through October 2018 for priority pollutants and through August 2019 for certain pollutants such as copper and heptachlor.

which utilizes three triggers for identifying RP (Table 1). All pollutants identified through the RPA were included in this local limits evaluation as potential pollutants of concern.

Table 1. Order R7-2020-0007 Reasonable Potential Triggers and RPA Results

SIP RP Trigger or Basin Plan Requirement	Description	Applicable Pollutants
Trigger1	Maximum effluent concentration (MEC) exceeds applicable Water Quality Objective (WQO). The WQO is most stringent of CTR freshwater, saltwater, or human-health-based objective.	Bis (2-Ethylhexyl) Phthalate, Copper, Cyanide
Trigger2	Receiving Water ambient background concentration exceeds a WQO (irrespective of MEC)	None
Trigger3	Other information indicates that a Water Quality-Based Effluent Limitation (WQBEL) is needed to protect beneficial uses of the receiving water	None
Basin Plan Requirement	WQBEL or technology-based limit is required by Colorado River Basin Plan or Total Maximum Daily Load (TMDL)	CBOD, TSS

2.3 Biosolids Criteria

The District’s DLD is regulated as a land application site under 40 CFR 503 biosolids regulations. As such, metals concentrations for arsenic, chromium and nickel are evaluated relative to the “exceptional quality” pollutant concentration limits for Table 3 of 40 CFR 503.13 (land application). For constituents that have no 40 CFR 503 land application limits, California hazardous waste criteria (Total Threshold Limit Concentration (TTLC) levels) are conservatively applied.⁵

Analytical results from biosolids monitoring for metals and other priority pollutants are included in Appendix B. A review of this data revealed no cases where the concentration of a pollutant would contaminate or limit the WWTP’s ability to beneficially reuse its biosolids. Therefore, no additional POCs were identified on this basis.

2.5 Human Health and Safety Criteria

Human health and safety concerns include flammable or explosive atmospheres and generation of toxic fumes. Protection of workers against flammable and explosive atmospheres and toxic gases are currently and adequately addressed through general prohibitions on discharges in the District’s Sewer Ordinance, through the existing limitations on oil and grease and total toxic organics, and

⁵ The hazardous waste criteria are wet weight basis, but are applied as dry weight values, which is conservative.

through compliance by WWTP employees with CalOSHA confined space entry requirements. Total influent concentrations of volatile organics are well below levels that could result in exceedances of Health and Safety criteria. Therefore, no additional pollutants of concern are identified based on human health and safety criteria.

2.6 Air Quality Criteria

The WWTP's objectives regarding air quality criteria include complying with federal, state, and local air regulations and remaining below Title III and Title V thresholds under the Clean Air Act Amendments of 1990. The WWTP is not subject to the Title III program, nor does it hold a Title V major facility permit. Total influent concentrations of volatile organics are below levels that could result in exceedances of SCAQMD limits. Therefore, no additional pollutants of concern are identified based on air quality criteria.

2.7 Summary of Pollutants of Concern Included in Analysis

Based on the criteria and screening described above, the following constituents are identified as POCs and included in the headworks loading analysis that follows in Section 3:

- Metals/cyanide: arsenic, cadmium, chromium⁵, copper, lead, mercury, molybdenum, nickel, selenium, silver, zinc, cyanide.
- Conventional Pollutants: CBOD, TSS
- Organics: Bis (2-Ethylhexyl) Phthalate

Pollutants that are grouped for purposes of the current local limits (e.g., chlorinated hydrocarbons, total toxic organics), but which now have individual water quality objectives were evaluated for possible inclusion as POCs based on the individual pollutants/WQOs. The applicable WQOs are typically the values listed in the CTR and used in the RPA analysis.

3.0 MAXIMUM ALLOWABLE HEADWORKS LOADING ANALYSIS

3.1 Description of MAHL Methodology

A spreadsheet model is used to analyze sample data and (if necessary) to calculate local limits based on the MAHL methodology. The model simulates the methodology and calculations found in the EPA's *Guidance Manual*. Equations used in the model's calculations are listed in Appendix A.

The fundamental objectives of establishing local limits are:

- To prevent pass-through of untreated pollutants that could violate NPDES effluent limitations or applicable water quality standards.

⁵ The NPDES Permit allows the use of total chromium sample data to assess compliance with both the total chromium and hexavalent chromium water quality objectives. In developing an allowable headworks loading for chromium/chromium VI based on receiving water criteria in Section 3.4, the more stringent hexavalent chromium water quality objectives were used.

- To prevent the introduction of pollutants into the WWTP that could interfere with operation or cause inhibition of the treatment processes.
- To prevent contamination of WWTP biosolids that would limit their beneficial reuse.
- To protect employee health & safety.

The first three criteria are referred to as pass-through, inhibition, and sludge quality. The headworks analysis utilizes WWTP monitoring data, process information, the numeric standards and criteria that apply to the WWTP effluent and sludge, and numeric values for inhibition. Monitoring data includes daily and monthly average flows, influent/effluent concentration data, additional “in plant” process concentration data (if available), residential and other non-industrial flow/concentration data (when needed for calculation of local limits). Removal efficiencies for individual pollutants are determined based on the influent/effluent data.⁸ For this analysis, site-specific WWTP influent/effluent data were available for calculating overall WWTP pollutant removals, except as noted in Section 3.3. Literature values from the *Guidance Manual* were used in estimating “in-plant” performance (e.g., removal across primary treatment), in order to determine allowable headworks loadings for inhibition.

Using the influent loadings and the calculated removal efficiencies, the model calculates three separate headworks loading limitations (lbs/day in the WWTP influent stream) for each pollutant, based on the pass-through, inhibition and sludge disposal criteria. These are referred to as Allowable Headworks Loadings (AHLs). For conventional pollutants (CBOD, TSS and ammonia), AHLs based on plant design were also identified. The most restrictive (lowest) of the AHLs becomes the maximum allowable headworks loading (MAHL) for that pollutant. POCs identified in Section 2.7 were included in the MAHL analysis, except in cases where limitations of the data did not allow a MAHL (or reasonable estimate thereof) to be calculated. The observed average WWTP influent loadings are tabulated in lb/day and as a percentage of the MAHL.

For POCs with existing local limits, a threshold of 60% of the MAHL (80% for conventional pollutants) is used to trigger further evaluation as to whether the local limit should be revised. If a POC’s loading is below 60% of the MAHL, no further evaluation is deemed necessary, other than continued monitoring and periodic updating of the loading calculation. For loadings above 60%, the *Guidance Manual* recommends the following:

- If current POC loading exceeds the MAHL, the local limit should be revised, unless the exceedance is the result of an unusual, one-time event.
- If the current POC loading has increased significantly from the previous analysis, the POTW should investigate the cause, increase monitoring, or revise the local limit.

For constituents with no existing local limits, the same threshold is applied to the average POC loading. In addition, the maximum loading is compared to 80% of the MAHL (for toxics). For any

⁸ Literature data from the *Guidance Manual* can be substituted when POTW-specific data are not available. However, extensive use of literature data diminishes the validity of the calculated local limits.

POC that exceeds these thresholds, the recommendations from the *Guidance Manual* are applied to determine if a local limit should be established.⁹

In either case, other factors may be considered when deciding whether a new or revised limit is needed.¹⁰ If a new or revised local limit is warranted, the analysis continues to calculation of the maximum allowable industrial loading (MAIL) and allocation of the MAIL as a local limit.

Development (or Revision) of Local Limits

The following describes the procedure for cases where a new (or revised) local limit is warranted based on the MAHL analysis and subsequent evaluation:

The MAIL is calculated by first allocating the MAHL to 1) domestic/background/“unregulated” sources, based on loading estimates developed for those sources, and 2) a safety/expansion factor, typically based on a specified percentage of the MAHL. The mass that remains is the MAIL, which is allocated to “regulated” dischargers.¹¹

The *Guidance Manual* outlines five different approaches to establishing local limits based on the allowable industrial loading. The most common and straightforward approach is the uniform concentration method, which allocates the industrial load to all regulated discharges in proportion to their flow (i.e., as a uniform concentration). This approach results in reasonable and achievable limits if sufficient mass is available for allocation. However, if the MAIL for a given pollutant is low, and/or there are one or more high flow industries that are allocated (but may not require) a large portion of the MAIL, the uniform concentration approach may result in an unreasonably stringent limit that may not be achievable. In such cases, it may be appropriate to use one of the alternative allocation strategies outlined in the *Guidance Manual*.

3.2 Data Sources

Data used for the MAHL analysis include Permit-specified influent/effluent monitoring data, influent/effluent monitoring data to meet pretreatment requirements, and additional influent data collected by the WWTP for process monitoring purposes. Data from a four year period between February 2019 and February 2022 were used. All data used are tabulated in Appendix B.

⁹ For POCs whose maximum loading exceed the MAHL, the *Guidance Manual* recommends establishing a local limit. For loadings below the MAHL but above these thresholds, increased monitoring or a local limit is recommended if the thresholds are exceeded during the previous year, and a local limit is recommended if the thresholds are exceeded in two successive years.

¹⁰ For example, if the governing criteria for the MAHL is inhibition, the inhibition criteria (typically literature values that span a wide range) should be examined, as well as site-specific conditions that may indicate the presence or absence of inhibition. Shortcomings in the calculation procedure or detection limit effects may also introduce artifactual results that should be evaluated.

¹¹The allocation scheme reflects the concept that domestic/background/commercial sources are largely uncontrollable, while “permitted” industrial/commercial sources are controllable via the Pretreatment Permits that enforce the applicable categorical or local limits. In practice, discharges from a number of “unpermitted” industrial and commercial facilities are also controlled through targeted source control and pollution prevention efforts.

A small number of sample results were identified as probable outliers using statistical measures more stringent than those outlined in the *Guidance Manual*.¹³ The presence of outliers in the influent data set can skew the results of the analysis by overestimating the influent loadings, or by overestimating plant removal efficiency (particularly if the mean removal efficiency statistic is used to characterize removals). Values that were deemed to be outliers are clearly identified in the data tables in Appendix B.

Results that are non-detect can also skew the analysis. The *Guidance Manual* suggests possible statistical methods to address non-detect values. These methods are most effective when the data set contains a sufficient number of detectable results that can be used to predict the underlying distribution of detectable plus non-detectable data. This was generally not the case for Bis (2-Ethylhexyl) Phthalate for which the effluent results were almost entirely non-detectable. For metals, results were mostly in the detectable or DNQ range (below the reporting limit, but above the method detection limit), with the exception of cadmium and silver, for which essentially all of the effluent values were non-detect. For non-detects, the method detection limit (MDL) value was used as a conservative surrogate value. Because the MDL values were quite low, this substitution had minimal impact, and allowed reasonable estimates of removal rates (and MAHLs) to be calculated without resorting to more sophisticated methods for treating non-detect values.

Wastewater Flows

Flows are summarized in Table 2. The average WWTP influent flow over the period from February 2019 through February 2022 was 5.7 mgd. The influent flow exhibits some seasonal variability, with modest increases in flow during the wet season storm events. The average industrial flow of 0.05 mgd is based on Pretreatment Program 2020 values. This value includes all of the industrial process flow plus some of the industrial sanitary wastewater flow from one IU. The latter estimate represents the fraction of industrial sanitary flow that is monitored as “industrial flow” for purposes of local limits compliance. As indicated in Table 2, the difference between the plant influent and industrial flows represents the “unregulated” or background flow that is used in calculating MAIL values (if needed). Daily influent flow values are tabulated in Appendix B.

¹³ Values were identified as outliers if they were greater than 1.5 times the IRQ above the 75th percentile (Q3) and three standard deviations or greater above the mean. Outliers are listed in the data listings but not included in summary statistics or influent loadings.

Table 2. General Parameters

Item	Value	Units	Source
Average Influent Flow	5.7	MGD	Average influent flow for Feb 2019 – February 2022
Industrial Flow (Permitted SIUs)	0.05	MGD	2020 Pretreatment Program data
Residential/Commercial Flow	5.6	MGD	By Difference
Flow to Anaerobic Digester	0.023	MGD	Average flow for November 2018 – November 2021
Biosolids Production	3.11	Dry tons/day	2021 Annual Biosolids Report
Safety Factor ¹	10%	%	Per EPA <i>Local Limits Guidance Manual</i> .

1. Default value.

Sludge and Biosolids Flows

Sludge flow to the anaerobic digesters is used for the inhibition calculations. The flow volume listed in Table 2 is an average value for primary sludge flow as tracked in the WWTP’s Digesters workbooks (2018-2021). The value for “Biosolids Production” listed in Table 2 represents the average daily biosolids sent to surface disposal at the WWTP’s dedicated disposal site in dry tons as reported in the WWTP’s 2021 Annual EPA 503 Biosolids Report.

Plant Influent/Effluent Data

WWTP influent/effluent data were derived from the California Integrated Water Quality System (CIWQS) database (which has all permit mandated monitoring results), and the District’s Effluent and Influent Metals Excel tables. For metals and cyanide, the influent and effluent data sets typically consisted of 7-13 sample results per constituent and location (with the exception of copper, which consisted of 48 effluent values). For CBOD and TSS, the influent and effluent data sets consisted of approximately 155-156 samples per constituent and location. For Bis (2-Ethylhexyl) Phthalate, only one influent sample result and 25 effluent sample results were available. For molybdenum, there seven influent/effluent sample results were available¹⁴.

In all cases, the number of samples was deemed sufficient to evaluate whether changes to local limits were needed. All data used in the analysis are tabulated in Appendix B. Analytical Methods, number of samples, and typical ML, MDL values are listed in Table 3.

Influent loadings were calculated by multiplying the individual concentration values listed in Appendix B by the corresponding daily influent flow.

¹⁴ The seven influent/effluent molybdenum samples were supplemented by eight biosolids sample results. Molybdenum is identified as a POC only on the basis of biosolids quality.

Biosolids Data

Biosolids concentration data from the 4x/year sampling used to characterize biosolids quality for compliance with the EPA 503 requirements, and from semi-annual sampling conducted to meet the pretreatment requirements of the NPDES permit. Although the biosolids data are not used directly in the MAHL analysis, such data provide a supplement to the MAHL results. The biosolids data are tabulated in Appendix B.

Domestic/Background Data

A preliminary review of influent data from the Pretreatment Annual Reports, indicated that the influent loadings for most pollutants were below the expected MAHL values and that recalculation of existing or calculations of new local limits would likely not be necessary. Therefore, monitoring to establish “domestic/background” concentrations was deferred until the results of the MAHL analysis indicated such monitoring might be needed for specific constituents.

Table 3. Analytical Methods and No. of Samples

Parameter	Method(s)	Typ. RL ug/L	Typ. MDL ug/L	No. of Infl Samples	No. of Effl Samples
Arsenic	EPA 200.8	0.5	0.06	7	10
Cadmium	EPA 200.8	0.1	0.05	7	10
Chromium (tot)	EPA 200.8	0.5	0.05	7	8
Copper	EPA 200.8	0.5	0.15	7	48
Cyanide	SM4500-CN-C,E	3.0	0.9	7	4
Lead	EPA 200.8	0.25	0.06	7	10
Mercury	EPA 245.1 (Inf)	0.05	0.01	7	--
	EPA 1631 (Eff)	0.0005	0.0002	--	10
Molybdenum	EPA 200.8			7	7
Nickel	EPA 200.8	0.5	0.06	7	13
Selenium	EPA 200.8	1.0	0.4	7	10
Silver	EPA 200.8	0.1	0.02	7	10
Zinc	EPA 200.8	1.0	0.7	7	10
Bis (2-Ethylhexyl) Phthalate	EPA 625.1	3.0	0.5	1	25
CBOD	SM5210B-2001	0.1	0.02	155	155
TSS	SM2540D-1997	3.0	3.0	156	156

Note: RL and MDL values may have varied over the period of the sample data and may be lower for effluent samples. Values listed reflect the most recent effluent data.

Industrial Data

Concentration and flow data from the significant permitted industrial facilities (SIUs) were available from WWTP Pretreatment Program compliance monitoring. However, existing industrial loadings do not enter into the MAHL or MAIL calculations.

3.3 Removal Efficiencies

Representative removal efficiencies were calculated from influent and effluent data tabulated for POCs. The *Guidance Manual* suggests that the mean recovery efficiency (MRE) method may provide more representative results when the number of influent and effluent samples differ (i.e. are not all paired) and when sampling times are not adjusted for the time lag through the treatment process. For metals and conventional pollutants, there were typically a similar number of influent and effluent values. Although the samples were normally taken on the same day, the sample time was not adjusted for the time lag, so the use of the MRE was deemed to be the most appropriate metric and was used to characterize WWTP removals for all constituents. As indicated in Section 3.2, values reported as non-detect were evaluated at the MDL, resulting in conservative removal statistics relative to the pass-through criteria.

Seven plant influent/effluent data were available for molybdenum, which has 40 CFR 503 regulatory criteria for biosolids only. An MRE based on these values was calculated, and the observed molybdenum concentrations in WWTP biosolids were also compared directly to the criteria.

The calculated removal statistic for cyanide was negative, indicating that the average effluent concentration was greater than the average influent concentrations. This is not unexpected, since influent concentrations are low, and cyanide is known to be created through the disinfection process. The use of a negative removal statistic (rather than zero) is conservative and does not impact the validity of AHLs for pass-through or inhibition.

Literature values from the *Guidance Manual* were used to characterize removals across primary treatment for purposes of calculating the AHL for inhibition of secondary treatment. For inhibition of anaerobic digestion, the removal across primary treatment were again used to determine concentrations of metals in the anaerobic digester feed stream, because only primary sludge is routed to the digester. Inhibition was the limiting criteria only in the case of zinc.

3.4 MAHL Analysis

AHL Based on NPDES Permit Limits or Receiving Water Criteria (Pollutant Pass-Through)

Table 4 lists the AHLs based on the current NPDES permit effluent limits (maximum daily and average monthly). Also shown in Table 4 are AHLs for constituents that did not have effluent limits in the NPDES permit. The latter were developed by calculating surrogate effluent limits based on the applicable WQOs, using the same methodology as used for NPDES permit limits, i.e. per Section 1.4 of the *Policy for Implementation of Toxics Standards for Inland Surface Waters, Enclosed Bays, and Estuaries of California* (SIP). These calculations are shown in Appendix C.

Table 4. Allowable Headworks Loading (AHL) Based on NPDES Permit Limits or Applicable Water Quality Objective

Pollutant	Concentration Units	NPDES Permit Limits - Daily Max.	NPDES Permit Limits - Weekly Average	NPDES Permit Limits - Monthly Average	Receiving WQO-Based Limits - Daily Max2	Receiving WQO-Based Limits - Monthly Average2	Plant Removal Efficiency1 (%)	AHL based on Daily or Weekly Max. NPDES Permit Limits (lb/day)	AHL based on Monthly Avg. NPDES Permit Limits (lb/day)	AHL Based on Daily Max. WQO-based Limits (lb/day)	AHL Based on Monthly Avg. WQO-based Limits (lb/day)
Arsenic	ug/L				195	138	37.0%	--	--	14.7	10.4
Cadmium	ug/L				4.3	2.2	65.0%	--	--	0.6	0.3
Chromium	ug/L				12.4	11.2	78.7%	--	--	2.8	2.5
Copper	ug/L	15.9		9.0			91.9%	9	5	--	--
Cyanide	ug/L	8.5		4.3			-20.9%	0.3	0.2	--	--
Lead	ug/L				4.5	3.3	91.9%	--	--	2.7	2.0
Mercury	ug/L				0.1	0.1	97.6%	--	--	0.2	0.1
Molybdenum	ug/L						7.1%	--	--	--	--
Nickel	ug/L				63.2	54.6	43.8%	--	--	5.3	4.6
Selenium	ug/L				7.0	4.5	53.9%	--	--	0.72	0.46
Silver	ug/L				4.0	2.0	85.8%	--	--	1.3	0.7
Zinc	ug/L				137	93	84.6%	--	--	42	29
Bis (2-Ethylhexyl) Phthalate	ug/L	11.8		5.9			96.7%	17	8.6	--	--
CBOD	mg/L		40	25			95.1%	--	24,038	--	--
TSS	mg/L		45	30			96.8%	--	44,307	--	--

Notes:

1. Values listed are Mean Removal Efficiency (MRE) values. All source data is included in Appendix A.
2. These are surrogate effluent limits calculated from WQOs in the same manner as NPDES Permit effluent limits (i.e. per State Implementation Policy) - See Appendix Table C-1.
3. WQO-based limits for chromium are based on chromium VI WQOs, but are applied to total chromium. This is very conservative.
4. CBOD and TSS limits are for activated sludge effluent (EFF 001A). Limits for pond system are higher.



AHLs for CBOD and TSS based on Permit Limits may overestimate allowable loadings, as the high removals observed at current loadings for these constituents may not be sustained at greatly higher loading rates (see “AHL Based on Plant Capacity” below).

AHL Based on Biosolids Reuse Criteria

Table 5 lists the AHLs based on biosolids disposal/reuse criteria. The criteria for “exceptional quality” in Table 3 of 40 CFR 503.13 are the most stringent for all eight metals governed by the land application regulations. There are no 40 CFR 503 limits for silver and chromium, therefore the AHLs for these pollutants are governed by hazardous waste criteria.

AHL Based on Process Inhibition

Table 6 lists AHLs based on inhibition of secondary treatment and sludge digestion processes, respectively. As noted above, values from the *Guidance Manual* were used for percent removal through primary treatment and for the inhibition criteria. (Removals through primary treatment are used in the activated sludge inhibition calculations and in the sludge digestion inhibition calculations because primary sludge only is routed to the digester.) Inhibition data are not available for some constituents.

AHL Based on Plant Capacity

Calculated AHLs based on NPDES limits and observed removal efficiencies may overstate actual capabilities, if removal efficiencies decline at high loadings. This is more likely to occur with conventional pollutants, where removal efficiencies may not be maintained if influent loadings increase above plant design capacities (e.g. for aeration systems). For conventional pollutants, it is therefore appropriate to also consider AHLs based on plant design criteria.

Design criteria for CBOD and TSS (as plant design loadings) were determined from design concentration values in VSD’s 2015 *Water Reclamation Facility Final Master Plan*. Master Plan.

MAHL Determination

Table 7 shows the derivation of the MAHL, which is the most restrictive of the above-described AHLs. A review of Table 7 shows that the biosolids criteria govern the MAHL for two metals (arsenic and molybdenum). Receiving water quality objectives govern the MAHL for cadmium, chromium, lead, mercury, nickel, selenium, and silver; NPDES permit limits govern for copper, cyanide, and bis (2-ethylhexyl) phthalate; inhibition criteria govern for zinc; and plant design criteria govern for CBOD and TSS.

Table 5. Allowable Headworks Loading Based on Biosolids Disposal Criteria

Pollutant	Plant Removal Statistic1 (%)	California Haz. Waste Criteria2 (mg/kg)	40CFR 503.13 Table 1 Maximum Land App. Sludge Criteria (mg/kg)	40CFR 503.13 Table 3 "Exceptional Quality" Sludge Land App. Criteria (mg/kg)	Most Stringent Sludge Criteria (mg/kg)	Allowable Headworks Loading (lb/day)
Arsenic	37.0%	500	75	41	41	0.69
Cadmium	65.0%	100	85	39	39	0.37
Chromium	78.7%	2,500	--	--	2,500	19.75
Copper	91.9%	2,500	4,300	1,500	1,500	10.2
Cyanide	-20.9%	--	--	--	--	--
Lead	91.9%	1,000	840	300	300	2.0
Mercury	97.6%	20	57	17	17	0.11
Molybdenum	7.1%	3,500	75	--	75	6.6
Nickel	43.8%	2,000	420	420	420	6.0
Selenium	53.9%	100	100	100	100	1.2
Silver	85.8%	500	--	--	500	3.6
Zinc	84.6%	5,000	7,500	2,800	2,800	20.6
Bis (2-Ethylhexyl) Phthalate	96.7%	--	--	--	--	--
CBOD	95.1%	--	--	--	--	--
TSS	96.8%	--	--	--	--	--

Notes:

1. Values listed are Mean Removal Efficiency (MRE) values. All source data is included in Appendix A.
2. Cal. Hazardous Waste Criteria (TTLIC) are wet weight basis and are therefore conservative as applied here.

Table 6. Allowable Headworks Loading Based on Process Inhibition

Pollutant	Average Removal Efficiency through Primary Treatment ¹ (%)	Overall Plant Removal Efficiency ² (%)	Criteria for Inhibition of Activated Sludge ³ (mg/L)	Criteria for Inhibition of Anaerobic Sludge Digestion ³ (mg/L)	Allowable Headworks Loading - Inhibition of Secondary Treatment (lb/day)	Allowable Headworks Loading - Inhibition of Sludge Digestion ⁴ (lb/day)	Allowable Headworks Loading Most Stringent Criteria (lb/day)	Most Stringent Inhibition Criteria
Arsenic	0%	37.0%	0.1	1.6	4.7	-- ⁵	4.7	Secondary Treatment
Cadmium	15%	65.0%	1	20	56	25.6	26	Sludge Digestion
Chromium	27%	78.7%	10	130	650	92.4	92	Sludge Digestion
Copper	22%	91.9%	1	40	61	34.9	35	Sludge Digestion
Cyanide	27%	-20.9%	0.1	2.5	6.5	1.8	1.8	Sludge Digestion
Lead	57%	91.9%	1.0	340	110	114.4	110	Secondary Treatment
Mercury	10%	97.6%	0.1	--	5.3	--	5.3	Secondary Treatment
Molybdenum	--	7.1%	--	--	--	--	--	--
Nickel	14%	43.8%	1.00	10	55	13.7	13.7	Sludge Digestion
Selenium	15%	53.9%	--	--	--	--	--	--
Silver	20%	85.8%	--	13	--	12.5	12.5	Sludge Digestion
Zinc	27%	84.6%	0.30	400	20	284.2	20	Secondary Treatment
Bis (2-Ethylhexyl) Phthalate	--	96.7%	--	--	--	--	--	--
CBOD	--	95.1%	--	--	--	--	--	--
TSS	--	96.8%	--	--	--	--	--	--

Notes:

1. Values from *Guidance Manual*, Appendix R. Used to calculate activated sludge inhibition.
2. See Table 4 footnotes.
3. From EPA *Guidance Manual*, Appendix G. For most constituents, a range of threshold values is cited. In most cases, the very lowest (most conservative) values from these ranges are used above.
4. Only primary sludge is routed to the digester. Therefore, the removal efficiency through primary treatment rather than through the overall plant is used for the anaerobic digestion inhibition calculation.
5. An AHL for arsenic cannot be determined because of the removal efficiency through primary only is zero.

Table 7. Maximum Allowable Headworks Loading (MAHL)

Pollutant	AHL for Daily Max. NPDES Limits ¹ (lb/day)	AHL for Mo. Avg. NPDES Limits (lb/day)	AHL for Daily Max. Water Quality Objective (lb/day)	AHL for Mo. Avg. Water Quality Objective (lb/day)	AHL for Biosolids Disposal or Reuse (lb/day)	AHL for Inhibition (lb/day)	AHL for plant design (avg conditions) ² (lb/day)	Maximum Allowable Headworks Loading (MAHL) (lb/day)	MAHL Criteria
Arsenic	--	--	14.7	10.4	0.69	4.7	--	0.69	BIOSOLIDS
Cadmium	--	--	0.6	0.29	0.37	25.6	--	0.29	WQO
Chromium	--	--	2.8	2.5	19.8	92	--	2.49	WQO
Copper	9.3	5.3	--	--	10.2	34.9	--	5.26	NPDES Permit
Cyanide	0.33	0.17	--	--	--	1.8	--	0.17	NPDES Permit
Lead	--	--	2.7	2.0	2.0	110	--	1.96	WQO
Mercury	--	--	0.16	0.10	0.11	5.3	--	0.10	WQO
Molybdenum	--	--	--	--	6.6	--	--	6.61	BIOSOLIDS
Nickel	--	--	5.3	4.6	6.0	13.7	--	4.62	WQO
Selenium	--	--	0.72	0.46	1.15	--	--	0.46	WQO
Silver	--	--	1.33	0.66	3.6	12.5	--	0.66	WQO
Zinc	--	--	42.3	28.5	20.6	19.5	--	19.5	INHIBITION
Bis (2-Ethylhexyl) Phthalate	17	9	--	--	--	--	--	8.6	NPDES Permit
CBOD	--	24,038	--	--	--	--	21,753	21,753	Plant Design
TSS	--	44,307	--	--	--	--	20,516	20,516	Plant Design

Notes:

1. All are daily maximum except mercury, BOD and TSS, which are weekly average.
2. Plant design loadings based on use of activated sludge plant only (10 mgd max) at design concentrations of 246 mg/L TSS, 261 mg/L CBOD (313 mg/L BOD/1.2). Values are from 2015 *Water Reclamation Facility Final Master Plan*.

Table 8 compares the plant influent loadings to the calculated MAHL values. The shaded columns list the average influent loadings over the February 2019 – February 2022 period in both lb/day and as a percentage of the MAHL. An examination of Table 8 indicates that loadings for most POCs and conventional pollutants are significantly below the thresholds.

POCs that were evaluated by additional methods (molybdenum), are discussed in the following section.

3.5 Discussion of MAHL Results and Recommendations

Metals and Cyanide: For all metals and cyanide, the observed WWTP loadings are well below suggested MAHL thresholds that would trigger the need to calculate maximum allowable industrial loadings (MAILs) and recalculate existing (or develop new) local limits. Therefore, no further action is recommended with regard to local limits for these constituents.¹²

Molybdenum: The analysis indicates that current influent loading for molybdenum based on the AHL methodology is well below the MAHL (9.4%). Because molybdenum has regulatory criteria for biosolids only, this finding was checked by direct examination of the molybdenum concentrations measured in biosolids. The results, presented in Figure 2, confirm that molybdenum levels are far below the 40 CFR 503.13 Table 1 ceiling concentration. Therefore, no further action is recommended with respect to the molybdenum.

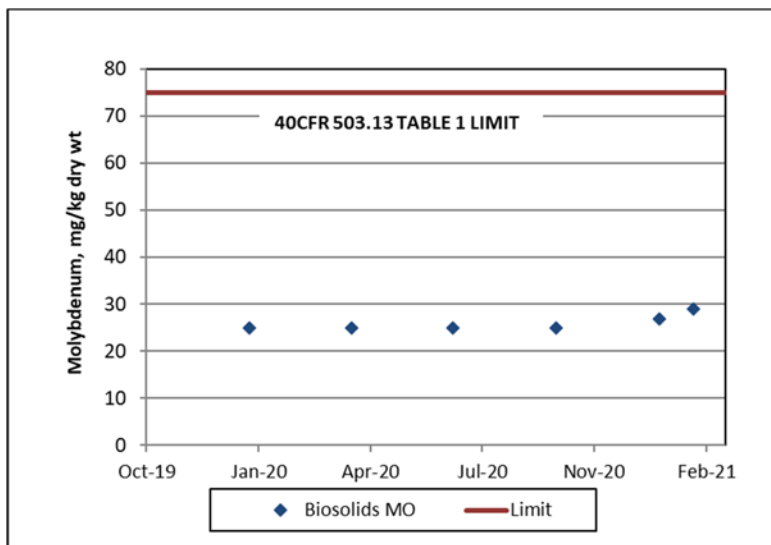

Figure 2. Concentration of Molybdenum in Biosolids

¹² As indicated in the *Guidance Manual*, the fact that a pollutant loading is well below the threshold values for revising local limits should not be interpreted to mean that the local limit is no longer required, since the existence of the limit may contribute to the loading being below the threshold. Therefore, in the absence of a specific need, existing limits are usually retained even though headworks loadings suggest that reductions may be possible.

Table 8. Comparison of Influent Loadings to MAHL

Pollutant	MAHL (lb/day)	MAHL Criteria	2019-2022 Average Influent Loading	
			(lb/day)	% of MAHL
Arsenic	0.69	BIOSOLIDS	0.051	7.3%
Cadmium	0.29	WQO	0.007	2.5%
Chromium	2.5	WQO	0.697	28.0%
Copper	5.3	NPDES Permit	1.93	36.8%
Cyanide	0.17	NPDES Permit	0.069	41.0%
Lead	2.0	WQO	0.048	2.5%
Mercury	0.10	WQO	0.0069	6.9%
Molybdenum	6.6	BIOSOLIDS	0.622	9.4%
Nickel	4.6	WQO	0.132	2.9%
Selenium	0.46	WQO	0.088	19.2%
Silver	0.7	WQO	0.016	2.4%
Zinc	19.5	INHIBITION	8.3	42.4%
Bis (2-Ethylhexyl) Phthalate	8.6	NPDES Permit	1.08	12.7%
CBOD	21,753	Plant Design	12,930	59.4%
TSS	20,516	Plant Design	12,240	59.7%

4.0 SUMMARY AND CONCLUSIONS

This review analyzed 12 pollutants of concern (POCs) that were: 1) mandated by EPA for inclusion in a local limits analysis, 2) identified on the basis of the reasonable potential analysis (RPA) conducted for the most recent NPDES permit, or 3) included as a result of screening the remaining constituents that have effluent limits in the NPDES permit. Monitoring data collected over the most recent three-year period (February 2019 through February 2022) were used to calculate WWTP influent loading and pollutant removal rates for use in the analysis.

An AHL was calculated for each POC based on the observed pollutant removal through the treatment plant and criteria governing pass-through (NPDES effluent limits or water quality objectives), sludge quality, or process inhibition. For conventional pollutants CBOD and TSS, AHLs based on WWTP design criteria were also calculated. The most stringent (lowest) AHL for each pollutant was identified as the MAHL for that pollutant.

Current influent loadings were then compared to the MAHLs. Loadings for metals and cyanide were significantly below the 60% threshold for further evaluation or action.

Molybdenum, which is governed by criteria for biosolids only, was evaluated based on both the calculated MAHL and a direct examination of concentrations in biosolids samples. That evaluation determined that no further action is required for molybdenum.

The MAHL values for CBOD and TSS were governed by the AHLs for plant design, which, in both cases, were more restrictively than the AHLs based on permit effluent limits. Current influent loadings for CBOD and TSS were a greater fraction (~60%) of their calculated MAHL values than in the case of metals. This is a typical finding for conventional pollutants, and both were still safely below the threshold for further action recommended in the Guidance Manual for conventional pollutants (80% of MAHL).

The calculated influent loading for bis (2-ethylhexyl) phthalate was low relative to the AHL based on NPDES permit limits. Although this finding was based on very limited influent data, an examination of the effluent data, for which the vast majority of samples results were non-detect supports the conclusion.

The MAHL analysis and the alternative analysis described in the preceding paragraph indicate that the existing local limits are sufficiently protective to prevent violations of NPDES effluent limitations, inhibition of WWTP treatment processes, or contamination of WWTP biosolids that would limit current beneficial reuse. Therefore, consistent with the *Guidance Manual*, no additional local limits development (i.e. determination of maximum allowable industrial loadings and recalculation of local limits) was conducted, and no reductions in existing limits (or implementation of additional limits) is deemed necessary based on this analysis.

5.0 REFERENCES

1. Local Limits Development Guidance, USEPA Office of Wastewater Management, Publication # EPA 833-R-04-002A, July 2004
https://www3.epa.gov/npdes/pubs/final_local_limits_guidance.pdf
2. Valley Sanitary District Water Reclamation Facility Final Master Plan, MWH, September 2015

DRAFT

Appendix A

Equations Used to Calculate Allowable Headworks Loadings and MAHL

Equations for Calculating Allowable Headworks Loadings

Table 2: NPDES Permit Limits or Water Quality Criteria

$$L_{npdes} = \frac{0.00834 * Q_{wwtp} * C_{npdes}}{(1 - R_{wwtp})}$$

Where:

- L_{npdes} = Allowable headworks loading based on NPDES permit or water quality requirements, lbs/day
- Q_{wwtp} = WWTP flow, MGD
- C_{npdes} = NPDES permit limit or water quality-based "surrogate limit", ug/L*
- R_{wwtp} = WWTP removal efficiency from headworks to plant effluent (as decimal)
- 0.00834 = Conversion factor for ug/L units. For mg/l, use 8.34

Table 3: Biosolids Reuse or Disposal Criteria (conservative pollutants):

$$L_{bio} = \frac{Q_{bio} * C_{bio} * 2000}{R_{wwtp} * 1,000,000}$$

Where:

- L_{bio} = Allowable headworks loading based on biosolids criteria, lbs/day
- Q_{bio} = Biosolids production, dry tons/day
- C_{bio} = Biosolids concentration limit, mg/kg dry basis
- R_{wwtp} = WWTP removal efficiency from headworks to plant effluent (as decimal)
- 2000 = Conversion factor (tons to pounds)
- 1,000,000 = Conversion factor (converts mg/kg to kg/kg)

Note: the above formula differs from, but is equivalent to Formula 5.9 in the Guidance Manual. The two differ because the above formula uses dry tons per day instead of sludge flow (in mgd) and specific gravity.

Table 4: Inhibition of Secondary Treatment (Activated Sludge):

$$L_{inhib2} = \frac{8.34 * Q_{wwtp} * C_{inhib2}}{(1 - R_{prim})}$$

Where:

- L_{inhib2} = Allowable headworks loading based on inhibition of secondary treatment, lbs/day
- Q_{wwtp} = WWTP flow, MGD
- C_{inhib2} = Inhibition criteria for secondary treatment, mg/L
- R_{prim} = Removal efficiency from headworks to primary treatment effluent, as decimal
- 8.34 = Conversion factor

Equations for Calculating Allowable Headworks Loadings, continued

Table 4: Inhibition of Anaerobic Digestion (conservative pollutants):

$$L_{dig.inhib} = \frac{8.34 * Q_{dig} * C_{dig.inhib}}{R_w}$$

Where:

- $L_{dig.inhib}$ = Allowable headworks loading based on inhibition of anaerobic digestion, lbs/day
- Q_{dig} = Sludge flow to digester, MGD
- $C_{dig.inhib}$ = Inhibition criteria for sludge digestion, mg/L
- R_{wwtp} = Removal efficiency from headworks to plant effluent, as decimal
- 8.34 = Conversion factor

Table 4: Inhibition of Anaerobic Digestion (non-conservative pollutants):

$$L_{dig.inhib} = L_{infi} * \frac{C_{dig.inhib}}{C_{dig.}}$$

Where:

- $L_{dig.inhib}$ = Allowable headworks loading based on inhibition of anaerobic digestion, lbs/day
- L_{infi} = Plant influent loading of pollutant, lb/day
- $C_{dig.inhib}$ = Inhibition criteria for sludge digestion, mg/L
- $C_{dig.}$ = Existing concentration in digester, mg/L

Table 5: Maximum Allowable Headworks Loading

$$MAHL = \text{Min} (L_{npdes}, L_{bio}, L_{inhib2}, L_{dig.inhib})$$

Where:

- L_{npdes} = AHL based on NPDES permit or water quality requirements, lbs/day
- L_{bio} = AHL based on biosolids criteria, lbs/day
- L_{inhib2} = AHL based on inhibition of secondary treatment, lbs/day
- $L_{dig.inhib}$ = AHL based on inhibition of anaerobic digestion, lbs/day

Only primary sludge is routed to the anaerobic digester at this treatment facility. Therefore, only the removal efficiency through primary treatment was used for the anaerobic digestion inhibition calculation.

Appendix B

Source Data:

Influent Flows

Influent / Effluent Metals, Conventional Pollutants and Organics

VSD Influent Flow, February 2019 - January 2020 (mgd)

Day	Feb-19	Mar-19	Apr-19	May-19	Jun-19	Jul-19	Aug-19	Sep-19	Oct-19	Nov-19	Dec-19	Jan-20
1	5.5	5.5	5.6	5.3	5.5	5.4	5.5	5.7	5.5	5.5	6.1	5.4
2	5.7	5.7	5.6	3.6	5.6	5.4	5.4	6.4	5.4	5.9	5.7	5.7
3	5.9	5.8	5.5	3.5	5.5	5.4	5.4	5.6	5.4	6.1	5.6	5.7
4	5.9	5.6	5.5	3.7	5.5	5.3	5.4	5.5	5.3	5.8	5.7	5.8
5	5.6	5.6	5.4	4.5	5.5	5.5	5.4	5.5	5.6	5.7	5.7	6.0
6	5.6	5.6	5.7	4.0	5.4	5.6	5.3	5.5	5.7	5.6	5.5	5.7
7	5.6	5.3	6.1	4.3	5.4	5.6	5.4	5.6	5.6	5.7	5.6	5.6
8	5.5	5.5	5.6	14.6	5.5	5.6	5.4	5.7	5.5	5.6	5.9	5.6
9	5.6	5.7	5.5	10.7	5.6	5.5	5.4	5.6	5.4	5.8	5.8	5.6
10	5.6	5.8	5.5	6.1	5.8	5.4	5.4	5.4	5.4	5.7	5.5	5.5
11	5.7	5.8	5.5	6.0	5.4	5.4	5.4	5.5	5.4	6.1	5.5	5.7
12	5.7	5.7	5.7	4.8	5.5	5.4	5.5	5.4	5.5	5.8	5.5	5.9
13	5.5	5.6	5.9	4.6	5.5	5.4	5.4	5.3	6.1	5.7	5.4	5.7
14	7.2	5.6	5.8	4.5	5.5	5.4	5.4	5.5	5.7	5.7	5.5	5.6
15	5.7	5.5	5.7	4.6	5.5	5.4	5.4	5.7	5.5	5.6	5.7	5.6
16	5.9	5.7	5.4	4.4	5.4	5.4	5.3	5.4	5.5	5.9	5.5	5.6
17	5.8	5.9	5.4	4.4	5.5	5.4	5.4	5.4	5.6	5.9	5.5	5.5
18	6.0	5.8	5.4	4.3	5.6	5.4	5.4	5.4	5.6	5.8	5.5	5.8
19	5.7	5.6	5.6	4.5	5.4	5.4	5.4	5.4	5.7	5.7	5.5	5.8
20	5.7	5.6	5.7	3.9	5.4	5.4	5.4	5.1	5.8	5.7	5.5	6.0
21	5.7	5.7	5.8	4.8	5.5	5.5	5.6	5.6	5.6	5.7	5.6	5.7
22	5.6	5.6	5.8	6.0	5.5	5.5	5.5	5.8	5.7	5.6	5.7	5.7
23	5.9	5.7	5.6	4.1	5.4	5.5	5.3	5.6	5.6	5.7	5.9	5.5
24	5.9	5.9	5.6	6.0	5.5	5.5	5.5	5.5	5.6	5.8	6.1	5.7
25	5.7	5.7	5.5	6.1	5.5	5.5	5.7	5.5	5.5	5.8	5.2	5.7
26	5.6	5.7	5.6	5.2	5.4	5.5	5.5	5.6	5.8	5.8	6.8	5.9
27	5.5	5.6	5.8	4.7	5.5	5.4	5.5	5.4	5.9	6.0	6.0	5.7
28	5.5	5.6	6.0	4.9	5.5	5.4	5.5	5.6	5.7	6.2	5.9	5.6
29		5.6	5.6	4.4	5.4	5.5	5.5	5.8	5.7	5.8	5.8	5.7
30		5.8	5.4	4.5	5.4	5.6	5.4	5.6	5.7	6.0	5.8	5.7
31		5.9		4.2		5.5	5.6		5.4		3.3	5.6
AVG	5.7	5.7	5.6	5.2	5.5	5.5	5.4	5.5	5.6	5.8	5.6	5.7

VSD Influent Flow, February 2020 - January 2021 (mgd)

Day	Feb-20	Mar-20	Apr-20	May-20	Jun-20	Jul-20	Aug-20	Sep-20	Oct-20	Nov-20	Dec-20	Jan-21
1	5.9	6.0	5.4	5.4	5.3	5.5	5.6	5.7	5.5	5.8	5.7	5.3
2	6.0	5.7	5.4	5.4	5.3	5.5	5.6	5.6	5.6	5.7	5.3	5.6
3	5.7	5.7	5.3	5.4	5.3	5.8	6.0	5.5	5.7	5.7	5.7	5.8
4	5.6	5.7	5.4	5.4	5.4	5.7	5.6	5.6	5.7	5.6	5.6	5.8
5	5.6	5.7	5.4	5.4	5.4	5.6	5.5	5.7	5.7	5.6	5.6	5.7
6	5.7	5.6	5.2	5.3	5.4	5.6	5.5	5.5	5.6	5.7	5.8	5.5
7	5.5	5.8	5.5	5.4	5.4	5.4	5.6	5.8	5.6	5.7	5.8	5.5
8	5.8	6.0	5.9	5.4	5.4	5.4	5.6	5.6	5.6	5.9	5.7	5.5
9	5.8	5.9	5.4	5.5	5.3	5.5	5.6	5.5	5.7	5.8	5.5	5.6
10	5.9	6.1	5.3	5.3	5.4	5.5	5.6	5.6	5.8	5.6	5.7	5.6
11	5.7	5.9	5.3	5.7	5.4	5.5	5.5	5.5	5.7	5.8	5.5	5.6
12	5.7	9.0	5.4	5.5	5.3	5.4	5.5	5.6	5.8	5.6	5.6	5.5
13	5.7	6.1	5.5	5.4	5.4	5.5	5.5	5.7	5.7	5.7	5.7	5.5
14	5.6	6.2	5.5	5.3	5.5	5.5	5.5	5.8	5.6	5.8	5.6	5.5
15	5.9	6.1	5.4	5.4	5.5	5.5	5.7	5.5	5.6	5.8	5.5	5.4
16	5.9	6.0	5.4	5.4	5.5	5.5	5.8	5.3	5.7	5.8	5.4	5.6
17	6.2	5.9	5.3	5.4	5.3	5.5	5.7	5.5	5.7	5.7	5.5	5.6
18	5.8	5.7	5.4	5.5	5.4	5.6	5.6	5.5	5.8	5.6	5.6	5.8
19	5.8	5.7	5.5	5.4	5.4	5.5	5.6	5.7	5.7	5.6	5.7	5.5
20	5.7	5.5	5.4	5.4	5.5	5.6	5.7	5.7	5.6	5.6	5.7	5.4
21	5.6	5.7	5.4	5.4	5.5	5.5	5.7	5.7	5.7	5.7	5.6	5.6
22	5.8	5.7	5.4	5.4	5.7	5.5	5.7	5.6	5.6	5.8	5.6	5.5
23	6.1	5.7	5.4	5.3	5.5	5.4	5.8	4.9	5.7	5.8	5.7	5.5
24	5.9	5.6	5.3	5.2	5.5	5.5	5.7	5.6	5.8	5.7	5.8	5.7
25	5.7	5.5	5.4	5.5	5.5	5.6	5.6	5.6	5.7	5.9	5.2	5.5
26	5.7	5.5	5.5	5.4	5.4	5.6	5.6	5.7	5.7	6.1	5.7	5.5
27	5.7	5.5	5.5	5.4	5.5	5.6	5.5	5.7	5.7	5.7	5.7	5.6
28	5.6	5.5	5.4	5.4	5.5	5.5	5.6	5.9	5.5	5.8	5.7	5.5
29	5.8	5.5	5.3	5.4	5.5	5.5	5.6	5.5	5.6	5.9	5.7	5.5
30		5.5	5.3	5.3	5.6	5.5	5.7	5.5	5.6	5.8	5.7	5.6
31		5.4		5.4		5.7	5.9		5.8		3.2	5.7
AVG	5.77	5.8	5.4	5.4	5.4	5.5	5.6	5.6	5.7	5.7	5.5	5.6

VSD Influent Flow, February 2021 - February 2022 (mgd)

Day	Feb-21	Mar-21	Apr-21	May-21	Jun-21	Jul-21	Aug-21	Sep-21	Oct-21	Nov-21	Dec-21	Jan-22	Feb-22
1	5.6	5.7	6.0	5.7	5.8	5.9	5.7	5.8	5.8	6.2	7.1	5.8	5.9
2	5.6	5.7	5.8	5.8	5.8	5.8	5.9	5.9	6.0	6.1	6.4	6.4	
3	5.6	5.7	5.9	5.8	5.8	5.8	5.8	5.8	6.1	6.1	6.1	6.2	
4	5.5	5.8	5.8	5.7	5.7	5.6	5.7	5.9	5.9	5.8	6.3	6.7	
5	5.6	5.7	5.9	5.7	5.9	5.9	5.8	5.9	5.9	5.8	6.4	6.4	
6	5.7	5.7	5.8	5.7	5.8	5.8	5.8	6.3	5.9	6.0	6.1	6.5	
7	5.7	5.9	5.7	5.7	5.8	5.8	5.8	5.9	5.8	6.2	6.0	6.3	
8	5.7	5.8	5.8	5.8	5.8	5.8	5.8	6.0	5.9	6.0	6.0	6.1	
9	5.6	5.7	5.9	5.7	5.7	5.8	5.9	5.8	6.0	6.1	6.0	6.4	
10	5.6	5.6	5.8	5.8	5.7	5.8	5.9	5.7	6.1	5.8	5.9	6.5	
11	5.5	5.7	5.8	5.8	5.7	5.7	5.9	5.9	6.0	6.0	6.1	6.5	
12	5.6	5.7	5.7	5.8	5.7	5.8	5.9	6.1	5.9	5.9	6.3	6.5	
13	5.6	5.7	5.7	5.7	5.7	5.8	5.7	5.8	5.9	6.0	6.1	6.3	
14	5.6	5.8	5.8	5.7	5.8	5.8	5.8	5.8	5.8	6.2	5.9	6.0	
15	5.9	5.9	5.7	5.8	5.8	5.8	5.9	5.8	5.9	6.0	6.1	6.1	
16	5.7	5.6	5.7	5.8	5.8	5.8	6.0	5.7	6.2	6.0	5.8	6.2	
17	5.6	5.8	5.8	5.9	5.8	5.7	6.0	5.7	6.3	5.9	5.7	6.4	
18	5.6	5.7	5.8	5.8	5.8	5.7	5.8	5.9	5.8	6.1	5.9	6.0	
19	5.7	5.7	5.8	5.9	5.8	5.9	5.8	6.0	5.8	6.0	6.0	5.9	
20	5.7	5.8	5.7	5.7	5.7	5.9	5.7	5.9	5.7	6.1	6.0	6.3	
21	5.8	5.9	5.7	5.8	6.0	5.7	5.9	5.8	5.7	6.1	6.5	6.1	
22	5.7	5.9	5.8	5.8	5.9	5.7	6.1	5.8	5.8	6.2	6.2	6.0	
23	5.6	5.8	5.7	5.8	5.8	5.7	5.9	5.8	5.9	6.2	6.3	6.3	
24	5.6	5.8	5.8	5.9	5.9	5.7	5.8	5.8	6.0	6.2	6.4	6.0	
25	5.6	6.0	5.8	5.8	5.8	6.2	5.7	6.2	5.8	6.4	5.5	6.3	
26	5.6	5.8	5.8	5.7	5.7	6.5	6.0	6.1	5.8	5.9	6.1	6.4	
27	5.8	5.8	5.7	5.7	5.7	5.8	6.2	5.9	5.9	6.2	6.1	6.5	
28	5.8	5.9	5.8	5.7	5.9	5.7	6.4	5.8	5.8	6.1	6.2	6.0	
29		5.9	5.7	5.8	5.8	5.8	6.6	5.9	5.8	6.2	6.4	6.1	
30		5.8	5.6	5.8	5.8	5.9	6.4	5.8	6.0	6.1	6.5	6.4	
31		5.8		5.4		4.1	5.8		5.9		3.5	6.0	
AVG	5.65	5.8	5.8	5.8	5.8	5.8	5.9	5.9	5.9	6.1	6.1	6.2	5.9

CBOD Daily

Date	Influent Concentration (mg/L)
2/7/2019	308
2/14/2019	350
2/21/2019	306
2/28/2019	304
3/7/2019	323
3/13/2019	310
3/21/2019	313
3/28/2019	275
4/4/2019	293
4/11/2019	285
4/18/2019	301
4/25/2019	310
5/2/2019	293
5/9/2019	298
5/17/2019	296
5/23/2019	276
5/30/2019	305
6/6/2019	247
6/13/2019	274
6/20/2019	235
6/26/2019	306
7/3/2019	227
7/11/2019	240
7/19/2019	233
7/25/2019	219
8/1/2019	257
8/8/2019	300
8/15/2019	266
8/23/2019	242
8/29/2019	198
9/5/2019	244
9/12/2019	255
9/19/2019	212
9/26/2019	253
10/3/2019	188
10/10/2019	231
10/17/2019	204
10/23/2019	259
10/31/2019	242
11/7/2019	262
11/14/2019	251
11/21/2019	242
11/27/2019	272
12/5/2019	334
12/12/2019	263
12/18/2019	274
12/26/2019	340
1/2/2020	323
1/9/2020	317
1/16/2020	307
1/23/2020	237
1/30/2020	244
2/6/2020	0

Date	Effluent Concentration (mg/L)
2/7/2019	19.1
2/14/2019	30.2
2/21/2019	12.7
2/28/2019	15.9
3/7/2019	20.7
3/13/2019	15.8
3/21/2019	16.2
3/28/2019	13.9
4/4/2019	20.1
4/11/2019	15.9
4/18/2019	14.1
4/25/2019	13.1
5/2/2019	16.8
5/9/2019	19.9
5/17/2019	22.4
5/23/2019	28.1
5/30/2019	32.0
6/6/2019	32.1
6/13/2019	14.0
6/20/2019	31.1
6/26/2019	21.8
7/3/2019	23.1
7/11/2019	29.2
7/19/2019	13.0
7/25/2019	14.3
8/1/2019	13.4
8/8/2019	15.4
8/15/2019	12.0
8/23/2019	17.3
8/29/2019	10.6
9/5/2019	11.4
9/12/2019	14.2
9/19/2019	15.6
9/26/2019	9.4
10/3/2019	13.6
10/10/2019	10.8
10/17/2019	13.1
10/23/2019	8.8
10/31/2019	7.5
11/7/2019	9.3
11/14/2019	15.7
11/21/2019	9.6
11/27/2019	9.6
12/4/2019	8.9
12/12/2019	13.7
12/18/2019	13.5
12/26/2019	15.1
1/2/2020	10.5
1/9/2020	7.0
1/16/2020	10.3
1/23/2020	10.6
1/30/2020	27.7
2/6/2020	0
2/7/2020	10.4

Inf. Mass Loading (lbs/day)
14,359
21,046
14,496
13,970
14,385
14,582
14,775
12,798
13,538
13,097
13,656
14,271
12,927
13,098
12,985
12,269
13,609
11,165
12,546
10,583
13,883
10,204
10,709
10,493
10,046
11,746
13,436
12,024
10,778
9,033
11,213
11,548
9,548
11,711
8,482
10,480
9,596
12,032
10,959
12,455
11,890
11,524
13,634
15,794
11,976
12,500
19,310
15,463
14,805
14,441
10,930
11,538

CBOD Daily

Date	Influent Concentration (mg/L)	Date	Effluent Concentration (mg/L)	Inf. Mass Loading (lbs/day)
2/13/2020	265	2/13/2020	8.9	12,642
2/20/2020	224	2/20/2020	7.7	10,649
2/27/2020	164			7,796
3/5/2020	176	3/5/2020	< 6.6	8,337
3/12/2020	260	3/12/2020	10.6	19,407
3/19/2020	297	3/19/2020	10.1	14,044
3/26/2020	311	3/26/2020	11.1	14,240
4/2/2020	275	4/2/2020	9.2	12,316
4/9/2020	249	4/9/2020	8.9	11,255
4/16/2020	294	4/16/2020	9.8	13,143
4/23/2020	307	4/23/2020	11.6	13,826
4/30/2020	280	4/30/2020	11.6	12,353
5/7/2020	245	5/7/2020	11.6	10,932
5/14/2020	284	5/14/2020	12.0	12,577
5/21/2020	268	5/21/2020	9.0	12,047
5/27/2020	290	5/27/2020	8.9	12,964
6/5/2020	260	6/5/2020	9.5	11,796
6/11/2020	280	6/11/2020	7.9	12,540
6/18/2020	228	6/18/2020	12.2	10,325
6/25/2020	244	6/25/2020	10.1	11,233
7/2/2020	221	7/2/2020	11.4	10,082
7/9/2020	212	7/9/2020	9.8	9,671
7/16/2020	233	7/16/2020	7.6	10,629
7/23/2020	301	7/23/2020	7.6	13,631
7/30/2020	251	7/30/2020	7.8	11,430
8/6/2020	268	8/6/2020	6.6	12,226
8/13/2020	271	8/13/2020	8.6	12,386
8/20/2020	248	8/20/2020	5.5	11,727
8/27/2020	239	8/27/2020	6.7	11,023
9/3/2020	254	9/3/2020	10.9	11,693
9/10/2020	232	9/10/2020	10.0	10,758
9/17/2020	218	9/17/2020	10.9	10,018
9/24/2020	262	9/24/2020	11.9	12,171
10/1/2020	247	10/1/2020	8.0	11,268
10/8/2020	277	10/8/2020	11.0	12,960
10/15/2020	218	10/15/2020	7.8	10,145
10/22/2020	251	10/22/2020	10.6	11,702
10/29/2020	300	10/29/2020	11.3	14,011
11/5/2020	290	11/5/2020	8.6	13,544
11/12/2020	297	11/12/2020	11.8	13,945
11/19/2020	305	11/19/2020	13.4	14,245
11/25/2020	293	11/25/2020	10.1	14,491
12/3/2020	321	12/3/2020	8.3	15,126
12/7/2020	301	12/7/2020	9.2	14,434
12/17/2020	332	12/17/2020	10.3	15,090
12/23/2020	338	12/23/2020	12.1	15,955
12/30/2020	354	12/30/2020	14.7	16,799
1/7/2021	357	1/7/2021	13.3	16,495
1/14/2021	301	1/14/2021	8.4	13,857
1/21/2021	309	1/21/2021	14.6	14,354
1/28/2021	298	1/28/2021	9.1	13,769
2/4/2021	313	2/4/2021	13.4	14,462
2/11/2021	352	2/11/2021	9.2	16,205
2/18/2021	312	2/18/2021	9.5	14,624
2/25/2021	328	2/25/2021	10.5	15,346

CBOD Daily

Date	Influent Concentration (mg/L)
3/4/2021	323
3/11/2021	306
3/18/2021	327
3/25/2021	286
4/1/2021	285
4/8/2021	267
4/15/2021	271
4/22/2021	313
4/29/2021	323
5/3/2021	219
5/10/2021	219
5/17/2021	247
5/24/2021	243
6/1/2021	200
6/10/2021	332
6/15/2021	252
6/21/2021	252
7/1/2021	288
7/8/2021	269
7/15/2021	391
7/22/2021	331
7/29/2021	246
8/2/2021	220
8/12/2021	220
8/19/2021	234
8/26/2021	286
8/30/2021	186
9/7/2021	211
9/16/2021	248
9/23/2021	252
9/27/2021	229
10/4/2021	253
10/14/2021	275
10/21/2021	270
10/25/2021	218
11/4/2021	357
11/8/2021	255
11/18/2021	296
11/22/2021	242
12/2/2021	268
12/9/2021	280
12/16/2021	258
12/23/2021	264
12/28/2021	271
1/6/2022	300
1/13/2022	300
1/20/2022	366
1/24/2022	249

Date	Effluent Concentration (mg/L)
3/4/2021	13.7
3/18/2021	12.8
3/25/2021	16.7
4/1/2021	13.3
4/8/2021	14.4
4/15/2021	11.1
4/22/2021	8.9
4/29/2021	14.7
5/3/2021	12.0
5/10/2021	19.0
5/17/2021	16.0
5/24/2021	10.0
6/1/2021	16.0
6/10/2021	13.7
6/15/2021	12.0
6/21/2021	15.0
7/1/2021	5.4
7/8/2021	7.5
7/15/2021	7.5
7/22/2021	9.6
7/29/2021	8.5
8/2/2021	11.0
8/12/2021	16.0
8/19/2021	10.0
8/26/2021	12.0
8/30/2021	10.0
9/7/2021	7.0
9/16/2021	9.1
9/23/2021	13.7
9/27/2021	8.0
10/7/2021	8.0
10/14/2021	16.2
10/21/2021	15.4
10/25/2021	20.0
11/4/2021	15.5
11/8/2021	17.0
11/18/2021	16.1
11/22/2021	19.0
12/2/2021	12.0
12/9/2021	11.5
12/16/2021	10.0
12/23/2021	13.5
12/28/2021	16.0
1/6/2022	12.0
1/13/2022	< 5.0
1/20/2022	9.4
1/24/2022	22.0

Inf. Mass Loading (lbs/day)
15,516
14,598
15,654
14,240
14,143
12,982
12,838
15,010
15,247
10,648
10,575
12,092
11,977
9,624
15,755
12,190
12,526
14,051
13,102
18,750
15,845
11,879
10,734
10,734
11,300
14,240
9,897
10,312
11,872
12,127
11,249
12,470
13,211
12,880
10,472
17,239
12,781
14,985
12,473
14,394
14,058
12,545
13,783
14,013
16,138
15,763
19,200
12,418

# samples	155
# Detections	155
Max	391
Min	164

	155
	152
	32.1
	5.0

21,046
7,796

CBOD Daily

Date	Influent Concentration (mg/L)	Date	Effluent Concentration (mg/L)	Inf. Mass Loading (lbs/day)
Average	273		13.46	12,926
Median	271		11.64	12,642
Mean Removal (MRE)	95.1%			

Standard dev.	41.3
CV	0.15

5.26
0.39

2/6/2020 influent and effluent sample value identified as outliers and not included in summary statistic.
 Samples analyzed by Standard Methods 5210B-2001
 6/13/19, 6/26/19, 7/3/19, 7/11,19, 7/25/19, and 8/8/19 effluent sample values are averages of two sample values obtained on the same sampling date.

Copper

Date	Influent Concentration (ug/L)	Date	Effluent Concentration (ug/L)	Inf. Mass Loading (lbs/day)
		2/4/19	4.1	
		3/4/19	12	
		3/18/19	3.9	
		4/2/19	2.9	
		5/1/19	2.8	
		6/3/19	2.1	
		7/1/19	3.3	
		8/5/19	1.5	
		9/3/19	1.7	
		10/3/19	3.9	
		10/3/19	1.6	
		10/3/19	3.9	
		11/4/19	2.7	
		12/2/19	2.0	
		1/6/20	2.6	
		2/3/20	2.9	
		3/2/20	2.0	
		4/30/20	2.5	
		5/4/20	3.0	
		6/8/20	2.8	
		7/7/20	3.8	
		8/3/20	2.5	
		9/9/20	3.4	
		10/12/20	3.9	
		10/12/20	2.5	
		11/9/20	1.8	
		12/1/20	1.9	
		1/4/21	3.1	
		2/1/21	5.0	
		3/1/21	2.0	
		4/6/21	3.0	
		5/3/21	2.9	
		6/1/21	3.8	
		7/6/21	4.2	
		8/2/21	2.4	
		9/7/21	2.3	
		10/4/21	6.2	
		10/26/21	2.3	
		11/1/21	4.0	
		12/1/21	2.4	
		1/10/2022	3.5	
		1/7/22	3.8	2.4
		1/10/2022	2.1	1.6
		1/13/22	3.2	2.3
		1/18/22	3.2	2.1
		1/21/22	2.4	1.9
		1/24/22	4.0	1.5
		2/1/22	6.2	1.8
1/7/22	45			
1/10/22	30			
1/13/22	43			
1/18/22	41			
1/21/22	38			
1/24/22	31			
2/1/22	36			

# samples	7		47	
# Detections	7		47	
Max	45		6.2	2.4
Min	30		1.5	1.5
Average	38		3.1	1.9
Median	38		2.9	1.9

Mean Removal (MRE) 91.9%

Standard dev.	5.8
CV	0.15

1.05	
0.34	

All estimated (J) and non-detect (<) values included in summary statistics.

Samples analyzed by EPA Method 200.8

1/10/2022 2.1 ug/L effluent result from CIWQS. 1/10/2022 3.5 ug/L effluent result was in summary data provided by VS 3/4/19 effluent sample value identified as an outlier and not used in the summary statistics.

Molybdenum - biosolids

Date	Biosolids Concentration (mg/kg dry wt)
1/1/20	25.0
4/1/20	25.0
7/1/20	25.0
10/1/20	25.0
1/1/21	27.0
2/1/21	29.0
4/1/21	22.0
5/1/21	13.0

# samples	8
# Detections	
Max	29.0
Min	13.0
Average	23.9
Median	25.0

Molybdenum

Date	Influent Concentration (ug/L)
1/7/22	12
1/10/22	11
1/13/22	13
1/18/22	13
1/21/22	12
1/24/22	11
2/1/22	13

Date	Effluent Concentration (ug/L)
1/7/22	11
1/10/22	10
1/13/22	12
1/18/22	12
1/21/22	12
1/24/22	11
2/1/22	11

Inf. Mass Loading (lbs/day)
0.63
0.60
0.68
0.65
0.61
0.55
0.64

# samples	7
# Detections	7
Max	13.0
Min	11.0
Average	12.1
Median	12.0

	7
	7
	12.0
	10.0
	11.3
	11.0

0.683
0.549
0.622
0.629

Mean Removal (MRE)	7.1%
---------------------------	-------------

Samples analyzed by EPA Method 200.8

TSS Daily

Date	Influent Concentration (mg/L)
2/7/2019	280
2/14/2019	320
2/21/2019	270
2/28/2019	280
3/7/2019	380
3/13/2019	280
3/21/2019	240
3/28/2019	300
4/4/2019	220
4/11/2019	240
4/18/2019	340
4/25/2019	260
5/2/2019	280
5/9/2019	280
5/17/2019	157
5/23/2019	260
5/30/2019	420
6/6/2019	300
6/13/2019	260
6/20/2019	220
6/26/2019	260
7/3/2019	240
7/11/2019	240
7/19/2019	230
7/25/2019	240
8/1/2019	300
8/8/2019	420
8/15/2019	180
8/22/2019	260
8/29/2019	220
9/5/2019	200
9/12/2019	240
9/19/2019	260
9/26/2019	244
10/3/2019	224
10/10/2019	224
10/17/2019	236
10/23/2019	266
10/31/2019	238
11/7/2019	236
11/14/2019	238
11/21/2019	230
11/27/2019	228
12/5/2019	314
12/12/2019	268
12/18/2019	252
12/26/2019	348

Date	Effluent Concentration (mg/L)
2/7/2019	8.9
2/14/2019	6.5
2/21/2019	7.7
2/28/2019	6.0
3/7/2019	6.0
3/13/2019	7.5
3/21/2019	6.9
3/28/2019	8.7
4/4/2019	8.5
4/11/2019	11.6
4/18/2019	13.1
4/25/2019	10.8
5/2/2019	11.4
5/9/2019	14.3
5/17/2019	15.3
5/23/2019	13.5
5/30/2019	8.0
6/6/2019	10.9
6/13/2019	9.2
6/20/2019	9.6
6/26/2019	13.9
7/3/2019	10.4
7/11/2019	10.8
7/19/2019	10.2
7/25/2019	11.3
8/1/2019	7.9
8/8/2019	4.8
8/15/2019	3.9
8/22/2019	8.1
8/29/2019	8.1
9/5/2019	9.0
9/12/2019	8.5
9/19/2019	8.1
9/26/2019	7.2
10/3/2019	7.4
10/10/2019	9.0
10/17/2019	10.4
10/23/2019	9.8
10/31/2019	8.9
11/7/2019	9.2
11/14/2019	9.9
11/21/2019	9.8
11/27/2019	8.9
12/4/2019	8.6
12/5/2019	
12/12/2019	13.1
12/18/2019	8.9
12/26/2019	10.5

Inf. Mass Loading (lbs/day)
13,054
19,242
12,790
12,867
16,924
13,171
11,329
13,961
10,165
11,029
15,426
11,970
12,353
12,307
6,887
11,558
18,740
13,561
11,905
9,908
11,796
10,789
10,709
10,358
11,009
13,711
18,810
8,137
11,905
10,036
9,191
10,869
11,709
11,294
10,107
10,163
11,101
12,357
10,778
11,219
11,274
10,953
11,428
14,848
12,204
11,496
19,765

TSS Daily

Date	Influent Concentration (mg/L)
1/2/2020	340
1/9/2020	312
1/16/2020	250
1/23/2020	224
1/30/2020	274
2/6/2020	218
2/13/2020	236
2/20/2020	184
2/27/2020	222
3/5/2020	254
3/12/2020	228
3/19/2020	236
3/26/2020	220
4/2/2020	159
4/9/2020	256
4/16/2020	270
4/23/2020	296
4/30/2020	348
5/7/2020	246
5/14/2020	286
5/21/2020	254
5/27/2020	310
6/5/2020	296
6/11/2020	190
6/18/2020	266
6/25/2020	220
7/2/2020	239
7/9/2020	218
7/16/2020	186
7/23/2020	218
7/30/2020	214
8/6/2020	204
8/13/2020	210
8/20/2020	192
8/27/2020	200
9/3/2020	280
9/10/2020	188
9/17/2020	186
9/24/2020	240
10/1/2020	188
10/8/2020	192
10/15/2020	240
10/22/2020	266
10/29/2020	238
11/5/2020	240
11/12/2020	240

Date	Effluent Concentration (mg/L)
1/2/2020	5.8
1/9/2020	5.7
1/16/2020	7.4
1/23/2020	6.7
1/30/2020	10.6
2/6/2020	8.0
2/7/2020	7.8
2/13/2020	10.6
2/20/2020	9.2
2/27/2020	
3/5/2020	10.5
3/12/2020	13.5
3/19/2020	14.2
3/26/2020	14.1
4/2/2020	13.6
4/9/2020	18.5
4/16/2020	12.0
4/23/2020	11.4
4/30/2020	9.5
5/7/2020	9.9
5/14/2020	13.4
5/21/2020	11.2
5/27/2020	11.7
6/5/2020	12.6
6/11/2020	14.9
6/18/2020	9.3
6/22/2020	2.7
6/25/2020	2.7
7/2/2020	8.4
7/9/2020	11.2
7/16/2020	6.5
7/23/2020	7.2
7/30/2020	9.0
8/6/2020	6.6
8/13/2020	5.7
8/20/2020	6.0
8/27/2020	7.4
9/3/2020	10.2
9/10/2020	5.4
9/17/2020	8.8
9/24/2020	8.1
10/1/2020	7.4
10/8/2020	7.4
10/15/2020	8.5
10/22/2020	10.7
10/29/2020	8.3
11/5/2020	8.0
11/12/2020	9.4

Inf. Mass Loading (lbs/day)
16,276
14,572
11,759
10,331
12,957
10,291
11,258
8,747
10,553
12,032
17,019
11,160
10,073
7,121
11,572
12,070
13,331
15,353
10,976
12,666
11,418
13,858
13,429
8,509
12,046
10,128
10,903
9,945
8,485
9,872
9,745
9,306
9,598
9,079
9,224
12,890
8,718
8,547
11,149
8,577
8,983
11,169
12,401
11,116
11,209
11,269

TSS Daily

Date	Influent Concentration (mg/L)
11/19/2020	228
11/25/2020	274
12/3/2020	238
12/7/2020	256
12/17/2020	352
12/23/2020	354
12/30/2020	314
1/7/2021	430
1/14/2021	208
1/21/2021	248
1/28/2021	250
2/4/2021	256
2/11/2021	258
2/18/2021	296
2/25/2021	284
3/4/2021	280
3/11/2021	266
3/18/2021	254
3/25/2021	292
4/1/2021	216
4/8/2021	240
4/15/2021	244
4/22/2021	326
4/29/2021	246
5/3/2021	246
5/10/2021	244
5/17/2021	294
5/24/2021	218
6/1/2021	260
6/10/2021	334
6/15/2021	288
6/21/2021	260
7/1/2021	244
7/8/2021	290
7/15/2021	358
7/22/2021	272
7/29/2021	254
8/2/2021	290
8/9/2021	214
8/19/2021	218
8/26/2021	236
8/30/2021	214
9/7/2021	226
9/16/2021	212
9/23/2021	258
9/27/2021	270
10/4/2021	304
10/11/2021	240

Date	Effluent Concentration (mg/L)
11/19/2020	11.0
11/25/2020	8.6
12/3/2020	6.8
12/7/2020	8.1
12/17/2020	9.6
12/23/2020	9.7
12/30/2020	14.6
1/7/2021	10.7
1/14/2021	9.9
1/21/2021	14.3
1/28/2021	9.9
2/4/2021	15.6
2/11/2021	8.7
2/18/2021	8.6
2/25/2021	10.4
3/4/2021	12.3
3/11/2021	5.4
3/18/2021	10.2
3/25/2021	10.0
4/1/2021	12.0
4/8/2021	3.7
4/15/2021	3.9
4/22/2021	4.1
4/29/2021	5.0
5/3/2021	4.7
5/10/2021	5.7
5/17/2021	4.3
5/24/2021	4.1
6/1/2021	6.8
6/10/2021	3.2
6/15/2021	2.3
6/21/2021	2.3
7/1/2021	2.5
7/8/2021	4.0
7/15/2021	3.6
7/22/2021	3.3
7/29/2021	2.4
8/2/2021	4.0
8/9/2021	1.3
8/19/2021	5.2
8/26/2021	5.1
8/30/2021	4.6
9/7/2021	5.5
9/16/2021	2.8
9/23/2021	4.6
9/27/2021	6.8
10/4/2021	
10/11/2021	8.4

Inf. Mass Loading (lbs/day)
10,649
13,551
11,215
12,276
15,999
16,710
14,901
19,868
9,576
11,521
11,551
11,828
11,877
13,874
13,288
13,451
12,689
12,159
14,539
10,719
11,669
11,559
15,633
11,612
11,961
11,782
14,393
10,745
12,512
15,850
13,931
12,924
11,905
14,125
17,168
13,021
12,265
14,149
10,530
10,527
11,750
11,387
11,045
10,149
12,415
13,263
14,984
11,990

TSS Daily

Date	Influent Concentration (mg/L)
10/21/2021	224
10/25/2021	250
11/4/2021	286
11/8/2021	317
11/18/2021	228
11/22/2021	310
12/2/2021	206
12/9/2021	270
12/16/2021	238
12/23/2021	260
12/28/2021	383
1/6/2022	262
1/10/2022	274
1/20/2022	240
1/24/2022	240

Date	Effluent Concentration (mg/L)
10/21/2021	6.7
10/25/2021	7.6
11/4/2021	7.4
11/8/2021	7.2
11/18/2021	5.0
11/22/2021	5.6
12/2/2021	5.8
12/9/2021	6.9
12/16/2021	6.0
12/23/2021	7.4
12/28/2021	8.4
1/6/2022	5.8
1/10/2022	3.7
1/20/2022	4.2
1/24/2022	6.0

Inf. Mass Loading (lbs/day)
10,686
12,010
13,811
15,889
11,542
15,978
11,064
13,556
11,572
13,574
19,804
14,094
14,854
12,590
11,970

# samples	156
# Detection	156
Max	430
Min	157
Average	258
Median	250
Mean Removal (MRE)	96.8%

	156
	156
	18.5
	1.3
	8.3
	8.4

19,868
6,887
13,874
11,789

Standard dev.	48.1
CV	0.19

3.24
0.39

Samples analyzed by Standard Methods 2540 D-1997

All effluent sample values provided here for EFF-001C are flow-weighted values based on the flow and concentrations at EFF-001A and EFF-001B.

Appendix C

Calculation of Surrogate Effluent Limits Based on Applicable WQOs

Appendix C. Calculation of Surrogate Effluent Limits Based on Applicable Water Quality Objectives

Constituent	Arsenic	Cadmium	Chromium	Lead	Nickel	Selenium	Silver	Zinc	Mercury
Acute Aquatic Life Water Quality Objective (C)	340	4.3	16	92.18	508.57	20	3.4	129.89	
Chronic Aquatic Life Water Quality Objective (C)	150	2.2	11	3.59	56.54	5	NA	129.89	
Acute Translator	1	0.994	0.982	1	1	0.998	0.85	0.946	1
Chronic Translator	1	0.909	0.962	1	1	0.998		0.946	1
Acute Aquatic Life Water Quality Objective (C) - Adjusted	340	4.3	16	92	509	20	4.0	137	0
Chronic Aquatic Life Water Quality Objective (C) - Adjusted	150	2.4	11	3.6	57	5		137	0
Human Health Water Quality Objective (C)									0.051
Dilution Credit (D)	0	0	0	0	0	0	0	0	0
Ambient Background Concentration (B)									
Acute Aquatic Life Effluent Concentration Allowance (ECA)	340	4	16	92	509	20	4	137	0
Chronic Aquatic Life Effluent Concentration Allowance (ECA)	150	2	11	4	57	5	NA	137	0
Human Health Effluent Concentration Allowance (ECA)	NA	NA	NA	NA	NA	NA	NA	NA	0.051
Coefficient of Variation (CV)	0.25	0.60	0.07	0.22	0.10	0.34	0.60	0.29	0.37
(σ)	0.250	0.555	0.070	0.217	0.100	0.331	0.555	0.284	0.358
(σ) ₄	0.127	0.294	0.035	0.110	0.050	0.169	0.294	0.144	0.183
Z	2.326	2.326	2.326	2.326	2.326	2.326	2.326	2.326	2.326
Acute Multiplier	0.576	0.321	0.852	0.618	0.797	0.489	0.321	0.538	0.463
Chronic Multiplier	0.751	0.527	0.922	0.780	0.891	0.685	0.527	0.722	0.664
Long Term Average (Acute)	196.01	1.39	13.88	56.92	405.27	9.81	1.28	73.82	0.00
Long Term Average (Chronic)	112.64	1.28	10.55	2.80	50.40	3.43	NA	99.19	0.00
Lowest LTAs	112.64	1.39	10.55	2.80	50.40	3.43	1.28	73.82	0.00
n	4	4	4	4	4	4	4	4	4
(σ) _n	0.127	0.294	0.035	0.110	0.050	0.169	0.294	0.144	0.183
Z(AMEL)	1.645	1.645	1.645	1.645	1.645	1.645	1.645	1.645	1.645
AMEL Multiplier	1.222	1.552	1.059	1.191	1.084	1.301	1.552	1.255	1.330
MDEL Multiplier	1.735	3.114	1.174	1.619	1.255	2.043	3.114	1.860	2.158
AMEL (aquatic life)	137.6	2.2	11.2	3.3	54.6	4.5	2.0	92.6	0.0
MDEL (aquatic life)	195.4	4.3	12.4	4.5	63.2	7.0	4.0	137.3	0.0
AMEL (human health)	NA	NA	NA	NA	NA	NA	NA	NA	0.051
MDEL/AMEL Multiplier	1.420	2.006	1.109	1.360	1.157	1.570	2.006	1.482	1.623
MDEL (human health)	NA	NA	NA	NA	NA	NA	NA	NA	0.083

Definitions:

AMEL: Average Monthly Effluent Limitation

MDEL: Maximum Daily Effluent Limitation

Note:

Per SIP procedure, non-detect samples are evaluated at one-half the detection limit for calculating the CV value. If >80% of values are ND, CV=0.6.

Appendix D

Current Local Limits

TABLE 1

UNIFORM CONCENTRATION INDUSTRIAL USER EFFLUENT LIMITS¹

POLLUTANT	LOCAL LIMITS (mg/L)
Arsenic	4
Cadmium	0.4
Chromium	14
Copper	12
Lead	3
Mercury	0.1
Nickel	7
Silver	5
Zinc	15
Cyanide (Total) ³	5
Cyanide (Amenable) ³	1
Polychlorinated Biphenyls	0.01
Pesticides	0.01
Sulfide ⁴	5
Oil & Grease ³	400
Total Petroleum Hydrocarbons ³	25

¹ User subject to Federal Categorical Pretreatment Standards shall meet the requirements of 40CFR Chapter I Subchapter N Parts 405-471 in addition to the standards set forth above.

² Average daily maximum concentration shall be applied to a composite sample taken over the hours of industrial discharge. Values are subject to review during the permitting process to determine if high flow volumes from any user at the stated concentrations would cause pass-through of pollutants which is prohibited. In such cases, the General Manager may change the local limits to protect the facilities.

³ A minimum of four grab samples collected at least 15 minutes apart. The average will be used to determine compliance with the concentration limit.

⁴ A single grab sample will be used to determine compliance with the concentration limit.

Appendix E

Pretreatment Program - Industrial Discharger Information

Appendix E
Pretreatment Program - Industrial Discharger Information

Name	Classification	Average Flow (gpd)	Maximum Flow (gpd)	Primary Pollutants Monitored
Forager Project Inc.	Non-categorical Industrial	27,245	38,703	
CRH California Water, Inc.	Non-categorical Industrial	14,292	21,331	
John Benoit Detention Center	Non-categorical Industrial	14,589	23,833	



**Valley Sanitary District
Operations Committee Meeting
August 2, 2022**

TO: Operations Committee

FROM: Ron Buchwald, District Engineer

SUBJECT: Discuss the Purchase of a Combination Cleaning Truck for the District and Provide Feedback

Executive Summary

The purpose of this report is to provide information to the Committee on the planned purchase of a new Combination Cleaning Truck for the District.

Strategic Plan Compliance

This item complies with VSD Strategic Plan Objective 3.2: Increase use of technology to lower costs and improve reliability.

Fiscal Impact

No fiscal impact at this time. The purchase of a new combination cleaning truck is a substantial purchase. The full impact and method of selection will be brought forward to the full Board for approval.

Background

Combination cleaning trucks are an essential part of the District's equipment pool as it performs the necessary cleaning of sewer mains to prevent sewer system overflows (SSOs). These trucks are also used to respond to and clean up after an SSO. Without combination cleaning trucks, staff would need to rent a truck or hire a company to be on standby to relieve sewer mains of any overflows. Neither is ideal and both expensive. The cost to rent a combination cleaning truck is about \$4,500 per week (\$12,500/mo.). These rates fluctuate and can be higher or lower based on demand and availability.

VSD has two combination cleaning trucks; one as the primary cleaning truck and the other as a backup that is used approximately once a week. The primary cleaning truck is a 2014 Vactor truck made by Haaker and is 8 years old. The backup is a 2003 International truck and has experienced recurring maintenance issues from the start. Due to its age, it is becoming more difficult to find parts for this unit.

The purpose of having a backup truck is to allow service to the primary truck. Earlier this Spring when the 2014 truck needed service, the 2003 truck failed and required service as well. Both trucks were out for about 2 months due to back ordered or hard-to-find

parts and availability of service technicians. The only solution was to rent a combination cleaning truck at a significant cost that was not budgeted.

Combination cleaning trucks generally have a 10-year life cycle. With the above-mentioned issues and the long lead times to receive a new truck once purchased (6 to 12 months), staff has been proactive and started the process. Purchasing a new combination cleaning truck will allow the 2014 truck to become the backup and the 2003 truck will be sold. The proceeds partially will offset the cost of the new truck.

Staff has solicited information from various manufacturers of combination cleaning units including combination units that are recyclers. Recycler units have been modified to use the water from sewer mains as the water source for jetting sewer mains, which saves money (domestic water charges) and staff time to fill water tanks on the units. The Recycler units are generally more expensive up front, but the savings from water charges and staff time will offset some of this expense. Recycler units will likely have more required maintenance due to extra parts needed to allow usage of the sewer water. Recycler units also require staff to drive the trucks with the debris tank at least half full of water whereas the traditional trucks are driven with the debris tank empty.

To date, staff has had two demonstrations of a recycler unit by two different manufacturers: Kaiser Premier and Vacall. Staff is working with these manufacturers' representatives to obtain quotes for the recycling trucks. Staff has requested quotes from traditional truck manufacturers like Haaker. Staff has been very satisfied with the Haaker Vactor unit currently in use. The plan is to present quotes for both recycling trucks and non-recycling trucks to allow comparison of costs and operations. Staff is also requesting the manufacturer or vendor to use State or Federal procurement sites that satisfy the required formal bidding process. This will help secure the lowest possible price for either type purchased.

Once all the quotes have been acquired, staff will provide them to the Board with a recommendation and justification.

Recommendation

Staff recommends that the Operations Committee discuss the options and provide feedback.

Attachments

Attachment A: Presentation by John Ambramowski (Vactor Manufacturing) and Randy Wheelhouse & Brett Wise (Owen Equipment) at the 2018 American Public Works Association, Washington State Chapter Conference



DIVERSITY

Expedition

APWA
Washington

2018
Fall

October 3 - 5
2018

Wenatchee Convention Center
WASHINGTON



Combination Sewer Cleaners with Water Recycler Systems

John Abramowski – Vactor Manufacturing
Randy Wheelhouse & Brett Wise – Owen Equipment

DIVERSITY Expedition



- Owen – Vactor Dealer > 60 yrs
- Vactor Manufacturing, Inc. > 100 years

"Easy to Operate... Easy on the Cows"

LEMISH & SONS
Milking Machine Co.
GABRIEL, INDIANA

The AIRLINER

What USERS Say

The COMPANION

About FORDS MILKERS

Manufactured by MYERS-SHERMAN COMPANY



DIVERSITY *Expedition*



- Sewer cleaner is filled with clean water
- High pressure water jet propels the nozzle upstream from the manhole
- Withdraw nozzle using the powered reel to flush material toward the manhole
- Vacuum material and water from manhole into debris body
- Decant excess liquids back into sewer system.
- Repeat



- Truck is driven to water source
- Sewer cleaner is filled with clean water
- Truck is driven to cleaning site
- Traffic control set up
- On-site set-up takes place
- High pressure water jet propels the nozzle upstream from the manhole
- Withdraws nozzle using the powered reel to flush material toward the manhole
- Retract slowly to insure material is not dropped out
- Cleaning is performed in step fashion – material carrying capacity of nozzle limited
- Vacuums material and water from manhole into debris body
- Tear-down of set-up takes place
- Decants excess liquids back into sewer system
- Repeat



Combination Sewer Cleaning



- 7:00 – Start Day
- 7:30 – Fill w/ fresh water
- 7:45 – Drive to work site and set up
- 8:15 – Start Cleaning Line 1
- 8:45 – Tear Down
- 9:00 – Drive to get water and return to site
- 9:30 – Set up
- 9:45 - Start Cleaning Line 2
- 10:15 – Break
- 10:30 Tear Down
- 10:45 Drive to get water and return to site
- 11:15 – Return to site and set up
- 11:30 – Clean Line 3
- 12:00 – Tear Down
- 12:15 – Go to Lunch
- 1:00 – Take truck to dump site
- 1:30- Dump and Clean truck out
- 2:30 – return to PWD
- 3:00 – End Day

300-360 meters
cleaned



- Truck is driven to water source
 - Sewer cleaner is filled with clean water
 - Truck is driven to cleaning site
 - Traffic control set up
 - On-site set-up takes place
 - High pressure water jet propels the nozzle upstream from the manhole
 - Withdraws nozzle using the powered reel to flush material toward the manhole
 - Retract slowly to insure material is not dropped out
 - Cleaning is performed in step fashion – material carrying capacity of nozzle limited
 - Vacuums material and water from manhole into debris body
 - Tear-down of set-up takes place
 - Decants excess liquids back into sewer system.
 - Repeat
- > 20 Minutes

- Truck is driven to water source
 - Sewer cleaner is filled with clean water
 - Truck is driven to cleaning site
 - Traffic control set up
 - On-site set-up takes place
 - High pressure water jet propels the nozzle upstream from the manhole
 - Withdraws nozzle using the powered reel to flush material toward the manhole
 - Retract slowly to insure material is not dropped out
 - Cleaning is performed in step fashion – material carrying capacity of nozzle limited
 - Vacuums material and water from manhole into debris body
 - Tear-down of set-up takes place
 - Decants excess liquids back into sewer system.
 - Repeat
- > 20 Minutes



- Significant WATER SAVINGS
- Gets MORE LINES CLEANED per shift



Recycling - Why Now?



- Awareness of the value of potable water
- Awareness of the costs to process potable water and the wastewater
- Awareness of sewer overflows is heightened and fines assessed
- Prevention; Communities need to clean more lines more frequently
- Communities have fewer resources with ever-increasing demands

- The tough jobs are not anomalies – Just routines
- Operators don't want to run out of water - re-filling before empty.
- Operators focus on the cleaning
- Its SAFER
 - Traffic control
 - Entering & leaving work site

The Benefits



- Water Recycled – 10,000 gallons per shift
- Productivity
 - Cleaner lines
 - More lines cleaned (2x)
- Consider the alternatives



Common Stages of Recycler Systems

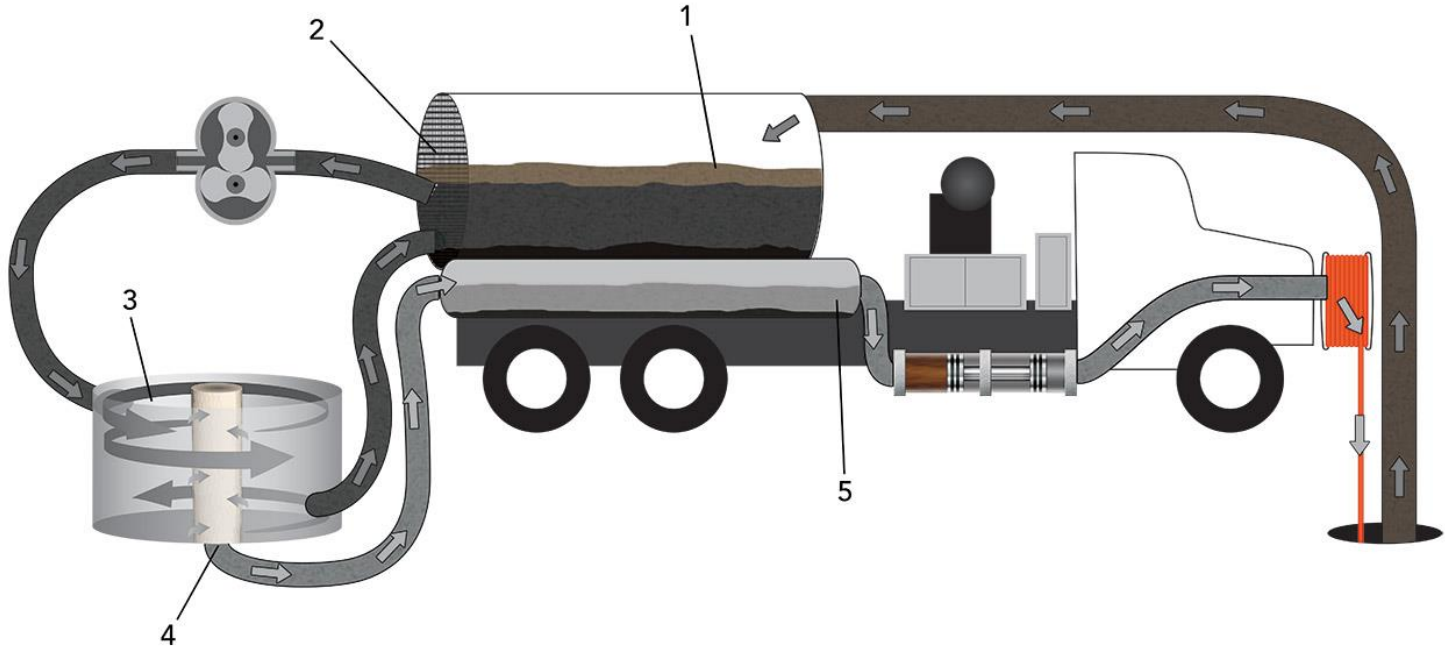



High velocity water centrifugally separates heavier solids

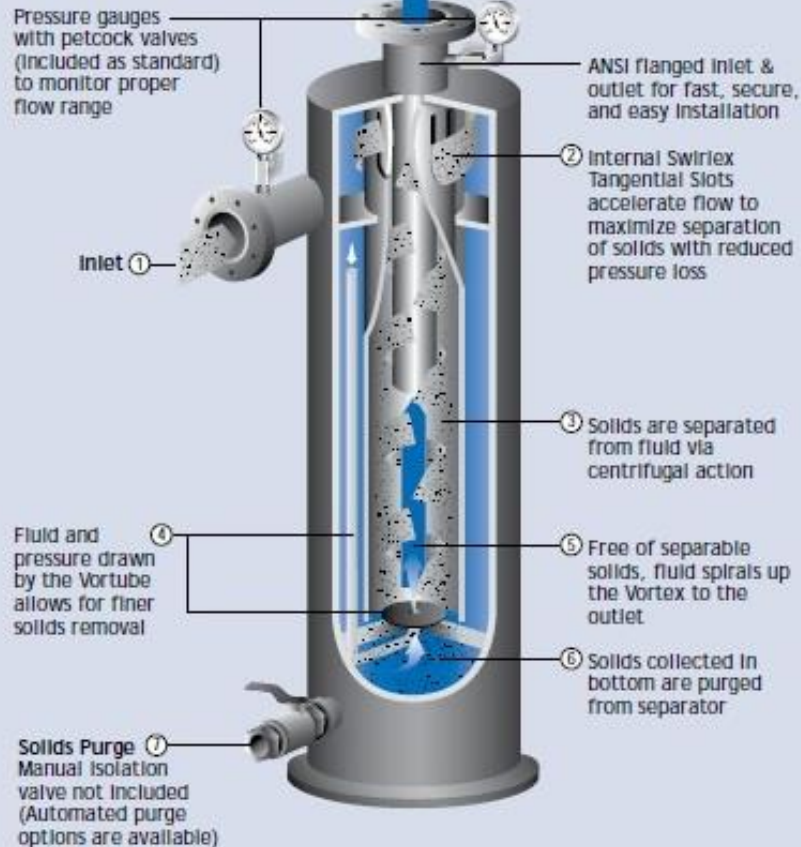

Stage 3 Centrifugal Separation



High velocity water
centrifugally separates
heavier solids



Stage 4 – Filter Systems

Eliminates all particles larger than XX micron to prevent abrasive solids in jetting system





Stainless steel or
Polymer reservoir
feeds the pump







- Green – Saves purified water (Water is precious!!)
 - Limited hydrants
- Productivity – Up to twice as productive....more with less
 - More line cleaning
 - Fewer overflows
 - Wasted time breaking down to fill
 - Wasted time driving to hydrants
 - Decant time
- Automated systems
- Quicker payback...powerful return on investment
 - Consider the alternative





- 7:00 – Start Day
- 7:30 – Drive to work site and set up
- 7:45 – Start Cleaning Line 1
- 8:30 – Start Cleaning Line 2
- 9:15 – Start Cleaning Line 3
- 10:00 – Break
- 10:15 - Start Cleaning Line 4
- 11:00 - Lunch

- 11:45 – Return to site and set up
- 12:00 –Start Cleaning Line 5
- 12:45 – Start Cleaning Line 6
- 1:30 – Start Cleaning Line 7
- 2:15 – Tear Down
- 2:30 – return to PWD
- 3:00 – End Day

630 - 850 meters
cleaned



- ~~Hydro-Excavation~~
- Sanitary systems
 - Pipe Diameter
 - Flow in the System
- Storm & Irrigation systems
 - Pipe Diameter
 - Flow in the System



- Continuous process vs batch (don't interrupt the cleaning process)
 - How many gallons can the system recycle?
- Filtration Level - Water quality matters to your TRUCK components
 - Target the smallest particle size
 - Understand what can get through the system. (level of filtration)
 - Pump tolerance
 - Component wear (Nozzles, fittings, etc.)
- Lowest water velocities in system – valves, pipes, pumps, hoses





- All systems have limits
 - How does the operator recover / restore performance ?
 - Where are the key components located?
- Materials of construction
 - Screens
 - Paper elements
- What is the ability/capacity to use the truck as a standard unit and how quickly?



Maintenance

- access and frequency.
- Location of filtration system



DIVERSITY
Expedition

Thank You





DIVERSITY *Expedition*



Thank You

HELP WANTED!

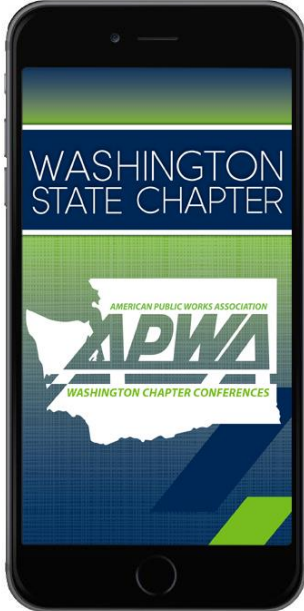

Please take a few minutes to use the evaluation form on the mobile app and provide your feedback on this session!

Evaluations help us select sessions for future conferences and provide valuable feedback for conference planners & speakers.

Thank you!